



**FULLY EXECUTED - CHANGE 1**  
Contract Number: 4400027736  
Original Contract Effective Date: 04/25/2023  
Contract Change Date: 10/18/2023  
Valid From: 10/01/2023 To: 09/30/2024

All using Agencies of the Commonwealth, Participating Political Subdivision, Authorities, Private Colleges and Universities

**Purchasing Agent**

Name: Green Alana  
Phone: 717-787-5053  
Fax: 717-346-3820

Your SAP Vendor Number with us: 150032

**Supplier Name/Address:**

STEPHENSON EQUIPMENT INC  
STEPHENSON EQUIPMENT INC  
7201 PAXTON ST  
HARRISBURG PA 17111-5198 US

Supplier Phone Number: 717-564-3434

Supplier Fax Number: 717-564-7580

**Please Deliver To:**

To be determined at the time of the Purchase Order unless specified below.

**Contract Name:**

Road Surface Patching Equipment

**Payment Terms**

NET 30

Solicitation No.:

Issuance Date:

Supplier Bid or Proposal No. (if applicable):

Solicitation Submission Date:

This contract is comprised of: The above referenced Solicitation, the Supplier's Bid or Proposal, and any documents attached to this Contract or incorporated by reference.

Item	Material/Service Desc	Qty	UOM	Price	Per Unit	Total
21	Base Units	0.000		0.00	1	0.00
22	Optional Equipment & Attachments	0.000		0.00	1	0.00
24	Installation/Labor Rate	0.000		0.00	1	0.00

**General Requirements for all Items:**

**Information:**

Supplier's Signature \_\_\_\_\_

Title \_\_\_\_\_

Printed Name \_\_\_\_\_

Date \_\_\_\_\_



**FULLY EXECUTED - CHANGE 1**  
Contract Number: 4400027736  
Original Contract Effective Date: 04/25/2023  
Contract Change Date: 10/18/2023  
Valid From: 10/01/2023 To: 09/30/2024

**Supplier Name:**  
STEPHENSON EQUIPMENT INC

**Header Text**

This contract is for:

What: Road Surface Patching Equipment

Why: Current one is due to expire on 9/30/2023

Please see Contract Overview for additional pricing information

Contact for DGS: Lisa Vega

Phone: 717-346-290

E-mail: lvega@pa.gov

No further information for this Contract

**Information:**



**FULLY EXECUTED**  
Contract Number: 4400027736  
Original Contract Effective Date: 04/25/2023  
Valid From: 10/01/2023 To: 09/30/2024

All using Agencies of the Commonwealth, Participating Political  
Subdivision, Authorities, Private Colleges and Universities

**Purchasing Agent**

Your SAP Vendor Number with us: 150032

Name: Vega Lisa  
Phone: 717-346-4290  
Fax: 717 346-3820

**Supplier Name/Address:**  
STEPHENSON EQUIPMENT INC  
STEPHENSON EQUIPMENT INC  
7201 PAXTON ST  
HARRISBURG PA 17111-5198 US

**Please Deliver To:**

To be determined at  
the time of the Purchase Order  
unless specified below.

Supplier Phone Number: 717-564-3434  
Supplier Fax Number: 717-564-7580

**Contract Name:**  
Road Surface Patching Equipment

**Payment Terms**  
NET 30

Solicitation No.: \_\_\_\_\_ Issuance Date: \_\_\_\_\_  
Supplier Bid or Proposal No. (if applicable): \_\_\_\_\_ Solicitation Submission Date: \_\_\_\_\_

This contract is comprised of: The above referenced Solicitation, the Supplier's Bid or Proposal, and any documents attached to this Contract or incorporated by reference.

Item	Material/Service Desc	Qty	UOM	Price	Per Unit	Total
21	Base Units	0.000		0.00	1	0.00
22	Optional Equipment & Attachments	0.000		0.00	1	0.00
24	Installation/Labor Rate	0.000		0.00	1	0.00

**General Requirements for all Items:**

**Information:**

Supplier's Signature \_\_\_\_\_  
Printed Name \_\_\_\_\_

Title \_\_\_\_\_  
Date \_\_\_\_\_



**FULLY EXECUTED**  
Contract Number: 4400027736  
Original Contract Effective Date: 04/25/2023  
Valid From: 10/01/2023 To: 09/30/2024

**Supplier Name:**  
STEPHENSON EQUIPMENT INC

**Header Text**

This contract is for:

What: Road Surface Patching Equipment

Why: Current one is due to expire on 9/30/2023

Please see Contract Overview for additional pricing information

Contact for DGS: Lisa Vega

Phone: 717-346-290

E-mail: lvega@pa.gov

No further information for this Contract

**Information:**



**COMMONWEALTH OF PENNSYLVANIA**  
*PENNSYLVANIA COMMERCIAL ITEM DESCRIPTION (PCID)*

**GENERAL REQUIREMENTS FOR BIDDING PennDOT VEHICLES/EQUIPMENT**

(This item description supersedes PCID No. 1075 eff. 5/15/18)

PCID NO. 1075  
Eff. 01/29/2020

These General Requirements shall apply to all on-road and off-road vehicles, highway equipment, agricultural equipment and construction equipment, procured for use by the Department of Transportation, Commonwealth of Pennsylvania (PennDOT). These requirements are in addition to any supplemental specifications identified in the invitation for bids. The following shall be considered MINIMUM requirements.

**A. STANDARDS, CODES, RULES, REGULATIONS:**

1. Each vehicle or unit of equipment shall conform to any and all requirements contained in the Pennsylvania Motor Vehicle Code.
2. Each vehicle or unit of equipment shall comply with all current applicable Federal Motor Vehicle Safety Standards, Federal and Pennsylvania Exhaust Emission and Noise Standards, and EPA and OSHA requirements. The appropriate decals indicating compliance shall be affixed to the vehicle/equipment.
3. Each vehicle or unit of equipment shall be manufactured in accordance with any codes, standards and engineering practices as recommended by the following professional organizations for the specific vehicle/equipment:

American Institute of Steel Construction (AISC)  
American National Standards Institute (ANSI)  
American Society of Mechanical Engineers (ASME)  
American Society for Testing and Materials (ASTM)  
American Trucking Association (ATA)  
American Welding Society (AWS)  
American Wood-Preservers Association (AWPA)  
Battery Council International (BCI)  
British Standards Institute (BSI): Limits and Fits  
Compressed Air and Gas Institute (CAGI)  
Industrial Fastener Institute (IFI)  
International Standards Organization (ISO)  
Joint Industrial Council (JIC)  
National Fire Protection Association (NFPA)  
National Truck and Equipment Association (NTEA)  
Power Crane and Shovel Association (PSCA)  
Society of Automotive Engineers (SAE)  
Society of Manufacturing Engineers (SME)  
Steel Structure Painting Council (SSPC)  
Tire and Rim Association (TRA)

**B. COMPONENTS, PARTS AND ACCESSORIES:**

1. When "No Substitute" components, parts or accessories are designated, only this type of component, part or accessory is acceptable.
2. All equipment and parts furnished shall be of the manufacturer's most current design, shall be included in its most current published list of models in stock and shall satisfy, these specifications. Only the most current production year will be accepted unless permission is granted in writing by specification section chief prior to delivery.
3. The same model components shall be utilized on all units supplied by the successful bidder under the specifications.
4. All electronic systems associated with the vehicle/equipment shall be properly insulated so as not to not cause any interference with the operation of the vehicle or the land mobile radio communications system, when properly installed in the vehicle.
5. Power systems must be compatible with the engine, transmission, axles, hydraulic system and power steering, etc., in order to meet the requirements specified herein.
6. Vehicles shall meet the maximum gradeability of the manufacturer when loaded to maximum Gross Vehicle Weight Rating ("GVWR") without exceeding the engine manufacturer's recommended maximum revolutions per minute ("RPM") based on maximum net torque.
7. Rear axle selection shall be made after the award and may be a mix of ratios as required. The successful vendor/manufacturer shall present three (3) computer runs showing the three most likely ratios for consideration for a top speed range of 55 MPH to 65 MPH max. Gear Selections shall provide gear ranges at 25 MPH & 35 MPH with a 1600 RPM to 1900 RPM range for plowing and spreading operations

**C SITE VISITS:**

Prior to submission of its bid, a bidder may contact PennDOT and schedule a site visit to inspect vehicles/equipment (as available) in PennDOT's current inventory in order to further clarify any drawings, pictures and specifications. Units may be available in the field for bidders to inspect at one or more of PennDOT's Maintenance Districts, but the Commonwealth makes no guarantee that any particular vehicle/equipment shall be located at a site convenient to the bidder's place of business. The site visit must be scheduled with the Fleet Management Division by calling (717) 783-2371. It is the bidder's responsibility to complete the site visit in time to submit a bid. All travel will be at the bidder's expense.

**D. ON BOARD VEHICLE/EQUIPMENT REQUIREMENTS:**

1. Each vehicle and unit of equipment shall include the proper forms to apply for a Pennsylvania title and license. These forms will include: the original manufacturer's statement of origin signed by the successful bidder and notarized. A detailed invoice listing all equipment, PO number, VIN numbers and price. All title papers shall be properly prepared and executed. The application for title, Form MV-1 shall indicate the name and address exactly as follows: Pa. Dept. of Transportation, Fleet Management Division, 17<sup>th</sup> Street and Arsenal Blvd., Harrisburg, PA 17120 (ATTN: Specifications Unit).
2. Trucks and trailers shall be certified to meet or exceed requirements to obtain a Pennsylvania license. For medium and heavy-duty trucks and vans, the GVWR shall be identified in the vehicle's cab as the final complete certification label (minimum rating). The Gross Combined Weight Rating (GCWR) shall be identified by decal in the cab to indicate the approved weight, which can be towed, if applicable.
3. Vehicles and Trailers designated for on-road/off-road use shall meet the following requirements:
  - a. Shall have a valid Pennsylvania state inspection sticker, if applicable.

- b. Shall have completed the manufacturers recommended pre-delivery service.

**D. ON BOARD VEHICLE/EQUIPMENT REQUIREMENTS:(Continued)**

- c. Shall have the vehicle and trailers manufacturer's model name and model number stated on a decal affixed to the inside of the driver's side door, if applicable.
- d. Shall be clean, lubricated, serviced, fuel tank filled to recommended capacity, propane units to include manufacturers recommended tank filled to recommended capacity, all adjustments completed, all mechanical and electrical motors and components fully functional and operational, and the vehicle will be "work ready" for immediate use.
- e. Shall have appropriately placed decals indicating the types of required fuels or lubricants and the capacity of each fluid's reservoir that is required by the vehicle.
- f. Shall have permanent antifreeze in each vehicle to protect it at a level of -35°F. Only a low silicate type anti-freeze will be used for vehicles having diesel engines.
- g. Shall be free from all dealer signs/emblems.
- h. Hydraulic systems shall be compatible with Universal Tractor Fluid (UTF).
- i. Shall include a copy of the manufacturer's warranty and service policy with all warranty vouchers, certificates and coupons as in accordance with section E (GENERAL WARRANTY REQUIREMENTS) as listed below.
- j. Shall have each vehicle and major component identified with a metal identification tag that provides the OEM's name, model number and individual serial number. Tags will be affixed in an accessible and readable position on the item.
- k. There shall be paper Operator, Maintenance and Repair manuals along with an electronic form of each manual on a USB thumb drive in Adobe PDF format. The paper operator's manual shall have a weather resistant holder attached to the unit.

The above items are pre-delivery service items, and bidders should not misconstrue these requirements with warranty problems that arise after the Commonwealth accepts the completed unit which complies with the written specifications.

**All charges for any of the aforementioned administrative, technical services and equipment are considered minimum acceptable requirements for delivery and shall be included in the bid price.**

**E. GENERAL WARRANTY REQUIREMENTS:**

The following warranty requirements are considered minimum unless otherwise stated in the invitation for bids. If the manufacturer's standard warranty exceeds the specified warranty, the manufacturer's standard warranty will apply. Manufacturer's warranty shall be provided in written or electronic form. All warranties will cover all labor and parts replacement, **without deductibles** during the warranty period, except as may be otherwise stated below or in the invitation for bids. This warranty, however, does not include items that must be replaced through ordinary wear and tear, but those parts ordinarily replaced through the servicing program will be replaced as part of the servicing program of equipment/vehicles, if appropriate. Parts replaced under this warranty will be of original equipment manufacturer (OEM) quality or higher. Service to the vehicle/equipment will be at a level to maintain or meet the manufacturer's requirements to sustain the warranty. All warranty policies shall be from the OEM and repairs shall be made at any authorized OEM warranty repair facility or in-house by Department personnel. Multiple repair facilities shall be located regionally around the State to support warrantable repairs.

1. A. CONSTRUCTION EQUIPMENT:

The construction and agricultural equipment manufacturer's service and warranty program for full machine ("bumper to bumper") shall be for a minimum of two (2) years or two thousand (2,000) hours whichever first occurs. Warranty requirements for the vehicle chassis, if unit is mounted on a truck chassis, must be met based on the GVWR of the vehicle. (Examples: aerial bucket truck, mini forestry unit, broom truck, etc.).

**E. GENERAL WARRANTY REQUIREMENTS: (Continued)**

2. A. LIGHT/MEDIUM DUTY TRUCKS & VANS (up to 26,000# GVWR):

The chassis manufacturer's service and warranty program shall consist of a 3 year/ 36,000mile bumper to bumper warranty at minimum. The manufacturer's standard powertrain warranty will be accepted, if it meets the minimum requirement of 5 years/ 60,000 miles. If the manufacturer's standard warranties exceed the specified warranties, the manufacturer's standard warranties will apply.

2.B. SERVICE/UTILITY BODY AND ASSOCIATED COMPONENTS WARRANTY (up to 26,000# GVWR)

Service/Utility bodies shall be warranted for five (5) years to include color fading and or any defects in the paint (cracking, poor adhesion, etc.) Steel service and utility bodies shall be warranted for five (5) years against defects and corrosion, including rust through or perforation from within. Surface rust caused by chip, scratches, or damage caused by PennDOT employees is not covered by this warranty. Associated components such as cranes, air compressors, and snowplows shall be covered by manufacturer's standard warranty. Manufacturer's standard warranty shall be provided in written or electronic form.

2.C. FLAT BED WARRANTY (up to 26,000# GVWR)

A vehicle's flatbed shall be warranted for three (3) years. This warranty covers both parts and labor for the full warranty period. A decal will be placed on the inside driver's door stating the warranty's terms and the name, address and telephone number of the contact person to initiate warranty claim services

3. A. HEAVY DUTY CAB & CHASSIS (26,000# GVWR or higher):

The chassis manufacturer's service and warranty program shall be for one (1) year/unlimited mileage. This warranty is defined as the base warranty covering the entire chassis. Additional warranty requirements can be found below.

3. ADDITIONAL SPECIFIC WARRANTY ITEMS (Applies to all vehicles 26,000# GVWR or higher)

a. RUST PROOFING WARRANTY

Cabs/cowls shall be warranted for five (5) full years with no mileage or hourly limitations. This will include rusting through or perforation from within. This warranty and service program covers both labor and parts for the full warranty period. Surface rust caused by chip, scratches, or damage caused by PennDOT employees is not covered by this warranty.

b. FRAME RAILS AND CROSSMEMBERS (Chassis)

For medium/heavy duty trucks, frame rails and cross members are warranted for five (5) full years with no mileage or hourly limitations. This warranty covers both parts and labor for the full warranty period. For light duty trucks and vans, the manufacturer's standard frame rail and crossmember warranty is acceptable.



c. FLAT BED WARRANTY

A vehicle's flat bed shall be warranted for three (3) years. This warranty covers both parts and labor for the full warranty period. A decal will be placed on the inside driver's door stating the warranty's terms and the name, address and telephone number of the contact person to initiate warranty claim services.

**E. GENERAL WARRANTY REQUIREMENTS: (Continued)**

3. HEAVY DUTY CAB & CHASSIS (26,000# GVWR or higher): (Continued)

d. SERVICE/UTILITY BODY AND ASSOCIATED COMPONENTS WARRANTY

Service/Utility bodies shall be warranted for five (5) years to include color fading and or any defects in the paint (cracking, poor adhesion, etc.) Steel service and utility bodies shall be warranted for five (5) years against defects and corrosion, including rust through or perforation from within. Surface rust caused by chip, scratches, or damage caused by PennDOT employees is not covered by this warranty. Associated components such as cranes, air compressors, and snowplows shall be covered by manufacturer's standard warranty. Manufacturer's standard warranty shall be provided in written or electronic form.

e. ENGINE AND TRANSMISSION WARRANTY

The engines for all Heavy/Medium Duty equipment/vehicles will be warranted for parts and labor for five (5) years or 150,000 miles (whichever first occurs). The engine warranty will include all items named or included within the valve covers, cylinder heads, block and oil pan. The transmission (automatic/manual) will be fully covered by the warranty and service program for three (3) years and will not be limited by mileage or hours. Electronic fuel delivery components, electronic control modules and emission control components shall be covered for five (5) years or 100,000 miles whichever first occurs. After treatment Device/DPF shall be warranted for minimum 5 years or 100,000 miles.

f. WARRANTY START UP DATE

The warranty startup date shall be defined as the date of transfer from PennDOT Fleet Management Division to the designated county location. This will be considered the day of delivery to the county and NOT the date of delivery by the successful bidder to the department. The PennDOT Fleet Management will supply the actual start-up date, equipment number and serial number of the machine, via email, to the successful bidder. It is the responsibility of the successful bidder to ensure that the equipment manufacturer recognizes and applies the departments actual warranty start-up date in their database.

**F. PILOT MODEL:**

PennDOT reserves the right to require the successful bidder to make mutually agreeable arrangements to deliver a "pilot model" for initial inspection. Pilot models(s) shall be delivered to the Department of Transportation, 17<sup>th</sup> St., & Arsenal Blvd., Harrisburg, PA 17120 for inspection, testing and approval. The remaining units shall not be delivered for inspection, testing and approval until after the pilot model has been accepted by PennDOT. The remaining units shall fully meet the requirements of the specifications and must be indistinguishable from the approved pilot model. Presentation of a pilot model will not be required if the quantity is only one (1) unit. The pilot model must meet all the mechanical requirements of the specifications. PennDOT may field test the equipment to determine if it meets the performance requirements of the specifications. Performance testing results will normally be completed within two (2) weeks of date of delivery. There are administrative items that are required to be presented at the pilot model inspection. It is imperative that all of these items be presented at this time so they are ready for shipment, when the balance of the units are delivered. PennDOT may withhold payment, where deemed necessary, pending receipt of these items. PennDOT disclaims any liability for damage to equipment that has not been unconditionally accepted by the PennDOT.

**G. DELIVERY:**

Any deviations to the specification must be granted in writing by the Chief of the Specification Section prior to delivery, previous acceptance will not be considered pre-approved. It shall be understood that any discrepancies/deviations between the specification and the completed unit(s), chassis or body up-fitter related, must be addressed and corrected prior to the delivery deadline and the Departments acceptances.

Time is of the essence. All units must be delivered within the number of days, specified in the invitation for bids, after receipt of the purchase order by the successful bidder. It shall be assumed by the parties that the successful bidder received the purchase order on the third business day following the date of the purchase order, unless the successful bidder provides credible evidence that the order was received on a later date. Bidders must specify delivery time in their bid. Phrases such as "as required", "as soon as possible", or "prompt" have no meaning and may be cause for rejection of the bid. The successful bidder shall deliver **the completed unit(s) wheeled and unwheeled at ground level (stacked loads are unacceptable)** to the Fleet Management Division, 17<sup>th</sup> Street and Arsenal Blvd. Harrisburg, PA 17120. All deliveries shall be made on a working day between 7:00 AM and 2:30 PM. There is a loading dock at this location; however, any additional unloading cost shall be borne by the successful bidder. The terms of delivery are also controlled by other provisions in the invitation for bids.

Paper work provided by the manufacturer, vendor or carrier company at time of delivery that requires a signature, will only be signed for verification of delivery. The signature will not endorse that the delivered equipment is free of defects or that the equipment meets the specifications or quote.

Upon delivery the department will review the equipment to ensure it follows the bid specifications and to ensure the unit is in satisfactory working condition. If it is determined that the unit has deficiencies, they must be corrected and addressed, to the satisfaction of the department in a timely manner before acceptance and a request for payment can be issued.

Each vehicle, trailer, attachment or unit of equipment shall include the proper forms to apply for a Pennsylvania title and license. These forms will include: the original manufacturer's statement of origin signed by the successful bidder and notarized. A detailed invoice listing all equipment, PO number, VIN numbers and price. All title papers shall be properly prepared and executed. The application for title, Form MV-1 shall indicate the name and address exactly as follows: Pa. Dept. of Transportation, Fleet Management Division, 17<sup>th</sup> Street and Arsenal Blvd., Harrisburg, PA 17120 (ATTN: Specifications Unit). All these forms and certificates will be delivered with the vehicle, trailer, attachment or unit at time of delivery to Fleet Management Division.

The successful bidder shall submit to the PennDOT "on a continuing basis", all service bulletins and technical letters as regularly issued by a manufacturer to dealers or large fleets. All the relevant information shall be supplied for the unit(s) forwarded to the Commonwealth to inform PennDOT of any improvements, changes and/or problems concerning the unit and its component parts. This information shall be addressed to the Pennsylvania Department of Transportation, Fleet Management Division, 17<sup>th</sup> St. & Arsenal Blvd., Harrisburg, PA 17120, ATTN: Specification Unit Chief, Fleet Management Division. PennDOT reserves the right to have its representative(s) periodically inspect each unit during assembly at the successful bidder's assembly point.

**H. PROCEDURE FOR IMPLEMENTING REPAIRS:**

In the event that a breakdown occurs, the repair work is to be performed by the successful bidder of record or his duly authorized representative within the Commonwealth. A copy of the successful bidder's work orders shall be supplied to the PennDOT County Equipment Manager and District Equipment Manager. Repairs assigned to the successful bidder can be performed at the successful bidder's place of business, at his duly authorized representative's place of business and, whenever possible, at the county maintenance facility or field locations. If services are to be performed at PennDOT's county maintenance facilities or in the field, the successful bidder must provide proof of insurance as stated in the contract attachments. County Equipment Managers shall notify the successful bidder or his duly authorized service representatives that the vehicle/equipment is down for component repairs and follow PennDOT standard procedure for handling warranty problems in accordance with the benefits of this warranty. At this time of notification, the location of repair is to be mutually agreed upon based on the most timely and cost effective basis to the Department. All work orders against the warranted repair shall be kept in PennDOT's Equipment History File at the county maintenance facility.

When repairs are to be performed at the successful bidder's place of business or his duly authorized representative's place of business, transportation of the vehicle/equipment within the Commonwealth of Pennsylvania shall be made by PennDOT. If determined by PennDOT that repairs cannot be handled within the Commonwealth, then transportation to and from the Commonwealth of Pennsylvania shall be the responsibility of the successful bidder.

**If mileage costs will be charged to the Department for the diagnosis or repair of a warrantable item, an estimate of these costs shall be given to the County Equipment Manager prior to the repair agreement.**

**I. LUBRICATION AND COMPONENT INFORMATION:**

The successful bidder shall provide lubrication and component information (as applicable) upon request by PennDOT. This information may be provided by copying and completing the sample forms attached to this document or may be presented on forms prepared by the successful bidder and/or manufacturer. (see attached sample forms – 4 pages).

**J. SUCCESSFUL BIDDER'S RIGHTS:**

The successful bidder shall have the right to make periodic inspections to ascertain that the maintenance techniques and/or repair procedures are being administered in accordance with the guidelines set forth in this document. Preventive maintenance shall be performed by PennDOT in accordance with the component manufacturer's recommended procedures, or as modified during the contract through supplements. All internal parts of the components shall be the repair responsibility of the successful bidder, except maintenance adjustments.

**K. MATERIAL MASTERS:** No Material Masters established for this delivery PCID.

**APPROVALS:**

Quality Assurance Specialist: Gerald Grecek, CPPB

Quality Assurance Supervisor: Brian Vulgaris

**Sample Forms (Instruction Sheet)**

**The Following Documents Shall Be Completed and Emailed / Shipped To**

Email: Contact the Automotive Equipment Specialist @ The Fleet Management Division @ 717-705-2124 (This is an Excel Spread Sheet; a Work Copy will be Emailed to You)

**Mail: Fleet Management Division  
17th & Arsenal Blvd.  
Harrisburg, Pa. 17120  
Attn: Specifications Division**

Note: These Forms Must Be Delivered to The Fleet Management Division with The Pilot Model!

**Instructions to Vendor for Completing the Attached Form  
(We Would Prefer Having This Completed Electronically)**

Electronic:

- 1. Obtain Work Copy by Calling 717-705-2124**
- 2. All Sections Are to be Filled Out**
- 3. Insert N/A in All Sections That Do Not Apply, Do Not Leave any Sections Blank**
- 4. Manufacturer, Model No. And Part No. Should Reflect the Actual Component Manufacturer**
- 5. Warranty Section Should Reflect the Coverage, The Vendor And/Or Equipment (Truck) Manufacturer Will Supply, Not the Component Manufacturer.**

Paper:

- 1. Same as Above, but Type or Print All Information**

# LUBE AND COMPONENT SHEET

<b>Equipment # Series</b>		<b>Effective Date</b>						
<b>PO Number</b>		<b>Unit Warranty Period</b>						
<b>Year</b>		<b>Engine Manufacturer</b>						
<b>Make</b>		<b>Engine Model</b>						
<b>Model</b>								
<b>VIN Number</b>								
<b>Vendor</b>		<b>Trans. Manufacturer</b>						
<b>Contact Person</b>		<b>Trans. Model</b>						
<b>Contact Phone Num.</b>		<b>Body Manufacturer</b>						
		<b>Body Number</b>						
<b>Oils &amp; Lubes</b>		<b>Filters</b>	<b>Qty. of Filters</b>	<b>Part Number</b>	<b>Com. Code 2810-</b>	<b>Make</b>	<b>Change Interval</b>	<b>Filters Stocked</b>
<b>Engine Oil</b>		<b>Engine Oil Filter</b>						
		<b>Engine Oil Filter Secondary</b>						
<b>Transmission Oil</b>		<b>Transmission Filter</b>						
		<b>Aux. Trans. Filter</b>						
<b>Fuel</b>		<b>Fuel Filter Primary</b>						
		<b>Fuel Filter Secondary</b>						
<b>Rear Axle / Axles</b>								
<b>Steering Oil</b>		<b>Steering Filter</b>						

<b>Hydraulic Oil</b>		<b>Hydraulic Filter Suction</b>						
		<b>Hydraulic Filter Return</b>						
<b>Coolant</b>		<b>Coolant Filter</b>						
<b>Transfer Case</b>								
<b>Front Axle</b>		<b>Air Filter Primary</b>						
<b>Brake Fluid</b>		<b>Air Filter Secondary</b>						
		<b>Air Compressor Filter</b>						
<b>Description</b>	<b>Manufacturer</b>	<b>Model Number</b>	<b>Part Number</b>				<b>Warranty</b>	
<b>Air Compressor</b>								
<b>Air Dryer</b>								
<b>Alternator</b>								
<b>Auto Slack Adjuster</b>								
<b>Auto Lube System</b>								
<b>Axle Front</b>								
<b>Axle Rear</b>								
<b>Battery</b>								
<b>Belt Air Compressor</b>								
<b>Belt Alternator</b>								
<b>Belt Fan</b>								
<b>Belt Power Steering</b>								
<b>Brake Chamber (FRT)</b>								
<b>Brake</b>								

<b>Chamber (REAR)</b>				
<b>Brake Lining (FRT)</b>				
<b>Brake Lining (REAR)</b>				
<b>Clutch Assembly</b>				
<b>Differential</b>				
<b>Dump Body</b>				
<b>Electronic Joysticks</b>				
<b>Engine (AUX)</b>				
<b>Engine (MAIN)</b>				
<b>Fan</b>				
<b>GL 400</b>				
<b>GL 400 Wiring</b>				
<b>Grote Wiring Harness</b>				
<b>Hoist Cylinder</b>				
<b>Hydraulic Pump - Main</b>				
<b>Pump, Fuel</b>				
<b>Pump, Hydraulic Aux.</b>				
<b>Pump, Steering</b>				
<b>Pump, Water</b>				
<b>Radiator</b>				
<b>Rexroth Valve</b>				
<b>Starter</b>				
<b>Steering Gear</b>				
<b>Suspension System</b>				

<b>Tank Fuel Capacity</b>				
<b>Tire Size Front LR</b>				
<b>Tire Size Rear LR</b>				
<b>Transaxle</b>				
<b>Transfer Case</b>				
<b>Transmission</b>				
<b>Wing Plow</b>				



**NOTES:**

To extend 8ft. beyond pintle.

**WIRING NOTES:**

- A. WHITE: GROUND - 10
- B. BLACK: MARKER -12
- C. YELLOW: LEFT TURN & BRAKE - 12
- D. RED: STOP / BRAKE -12
- E. GREEN: RIGHT TURN & BRAKE - 12
- F. BROWN: TAIL - 12
- G. BLUE: ABS -12

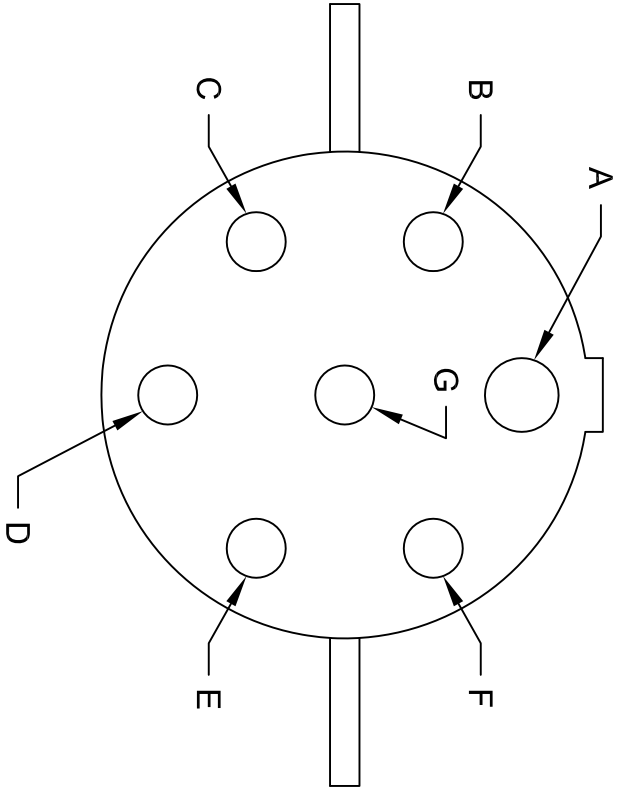
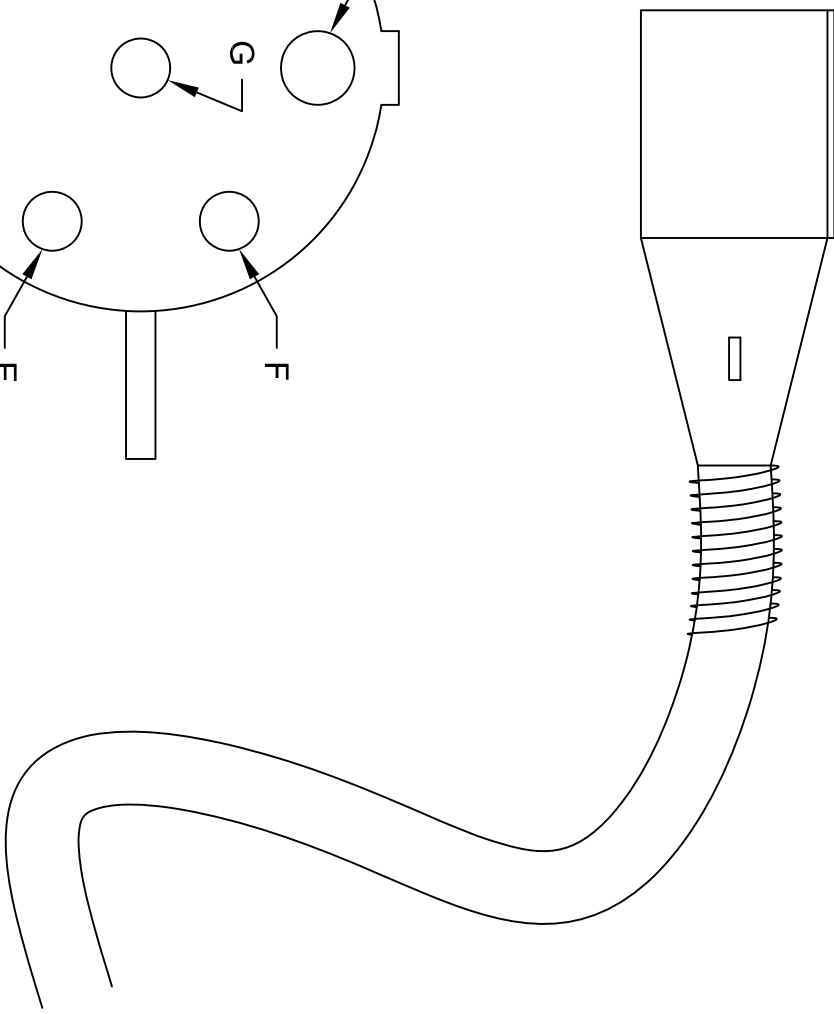

**PA DEPARTMENT OF TRANSPORTATION**

**REVISIONS**

NO.	DATE	BY	DESCRIPTION
1	5-16-2018	KBD	ROUND PIN MALE CONNECTOR
2			
3			

**WIRING DIAGRAM / 7 WAY**

**ROUND PIN MALE CONNECTOR**

DRAWN BY	SCALE	EQN-80B
JJB	N/A	

DATE	CHKD BY	SHEET 1 OF 1
08-02-16		

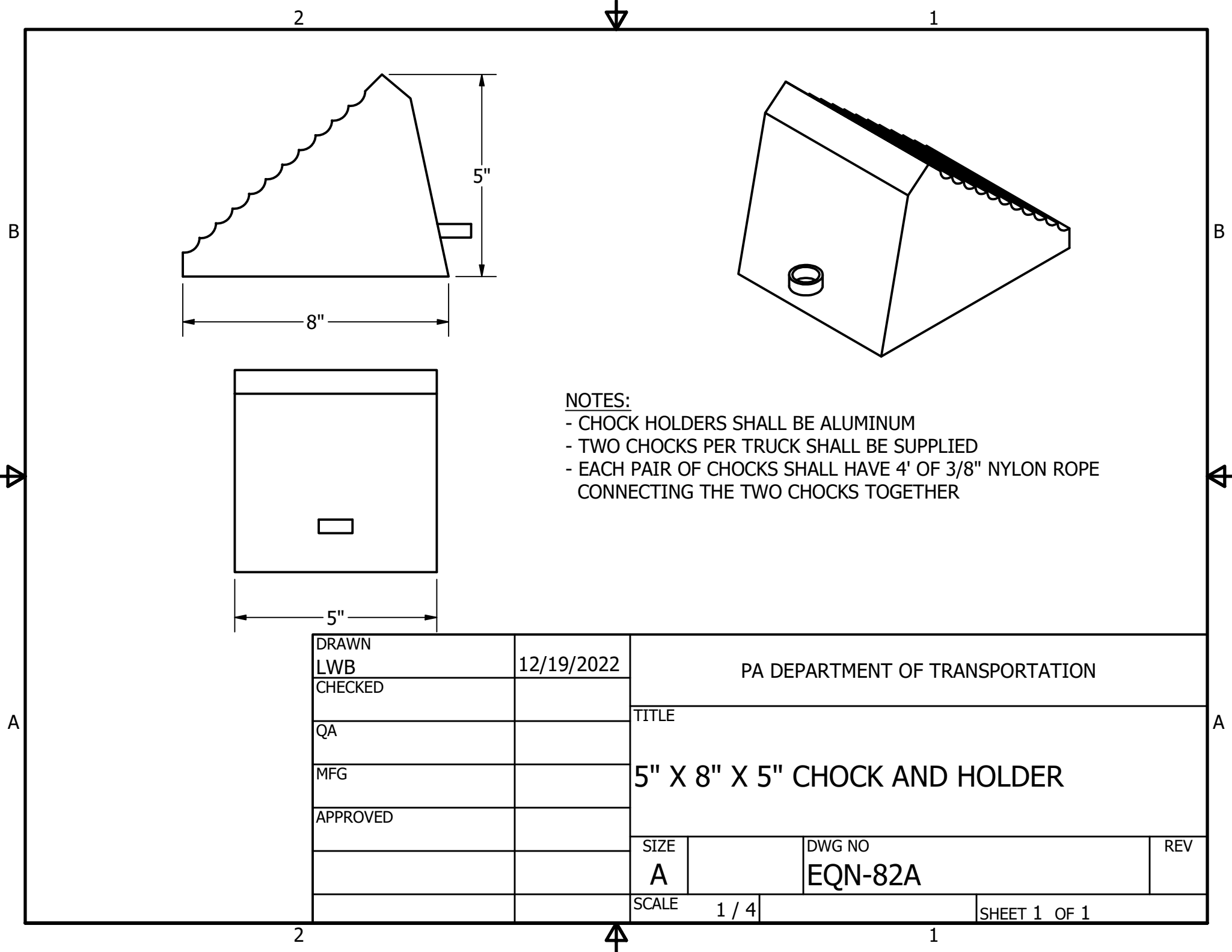

**NOTES:**

- CHOCK HOLDERS SHALL BE ALUMINUM
- TWO CHOCKS PER TRUCK SHALL BE SUPPLIED
- EACH PAIR OF CHOCKS SHALL HAVE 4' OF 3/8" NYLON ROPE CONNECTING THE TWO CHOCKS TOGETHER

DRAWN		12/19/2022		PA DEPARTMENT OF TRANSPORTATION		
LWB						
CHECKED				TITLE		
QA						
MFG						
APPROVED						
				SIZE	DWG NO	REV
				A	EQN-82A	
				SCALE	1 / 4	SHEET 1 OF 1

**5" X 8" X 5" CHOCK AND HOLDER**

SURGE-BRAKE ACTUATOR WITH 3in. LUNNETTE EYE. REF: DICO MODEL 20 OR DICO MODEL 10 OR EQUAL.

VARIABLE ADJUSTMENT BY COMBINATION OF ONE OR BOTH ADJUSTMENTS TO ALLOW 18in. TO 28in.

HEAVY DUTY (BOX CHANNEL PREFERABLE) DESIGN WITH MINIMUM CAPACITY NOT LESS THAN 10% MORE THAN TONGUE WEIGHT OF THE TRAILER.

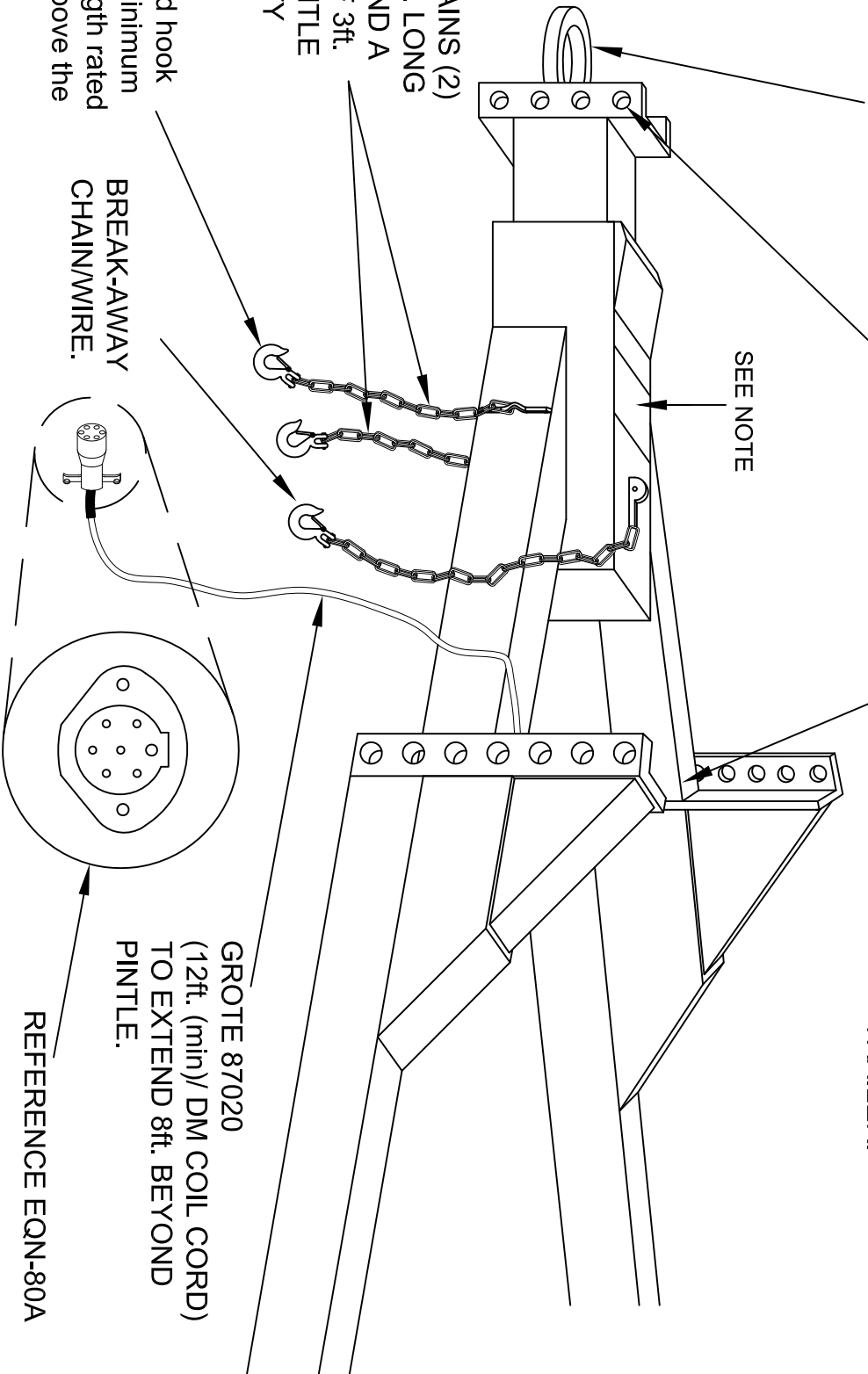

Each chain and hook shall have a minimum breaking strength rated equal too or above the GVWR.

ANY ALTERNATE OR ADDITIONAL DESIGNS RECOMMENDED BY THE MANUFACTURER SHALL BE SUBMITTED, IN WRITING, TO THE FLEET MANAGEMENT DIVISION SPECIFICATION UNIT FOR APPROVAL. IF A PERMANENT HITCH MUST BE UTILIZED IT SHALL BE SET AT 28 INCHES.

**NOTE:** THERE SHALL BE A COLE HERSEE, HOLDER 11750 MOUNTED IN THE TONGUE AREA.

**PA DEPARTMENT OF TRANSPORTATION**

**REVISIONS**

**TRAILER, FRONT END SPECIFICATIONS**

NO.	DATE	BY	ACT	DRAWN BY	DLW	SCALE	N/A	EQN-84-2018
1	08-21-14	ACT		JJB				
2	07-22-15	JJB						
3	05-16-18	KBD						

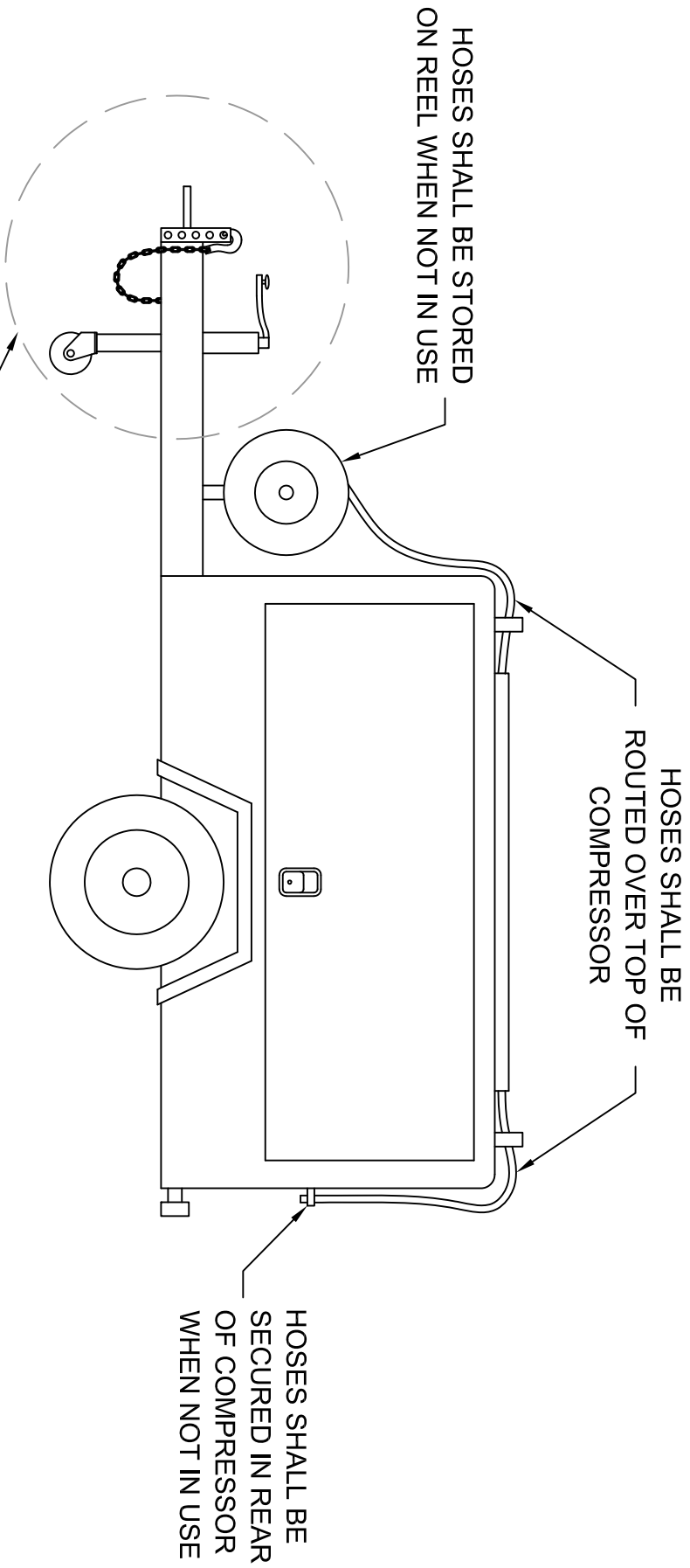

**PA DEPARTMENT OF TRANSPORTATION**

REVISIONS		AIR COMPRESSOR	
NO.	DATE	BY	
1			
2			
3			

DRAWN BY	JJB	SCALE	N/A	EQN-143
DATE	12-20-16	CHK'D BY		SHEET 1 OF 1

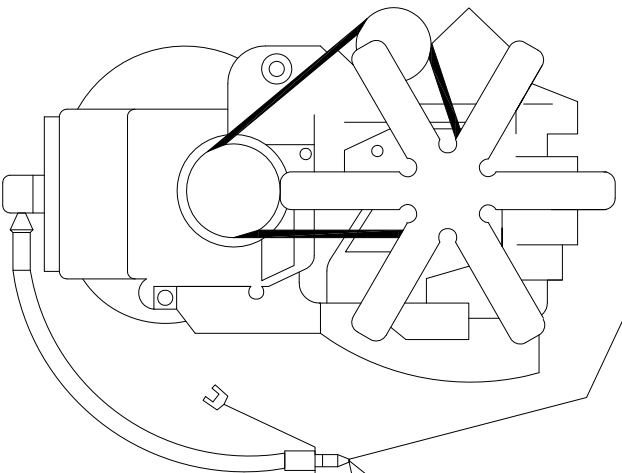
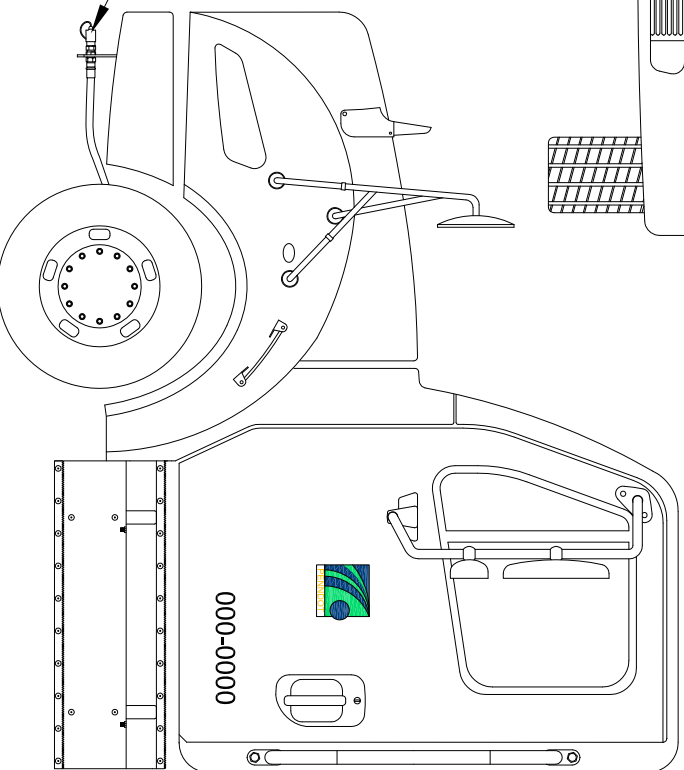
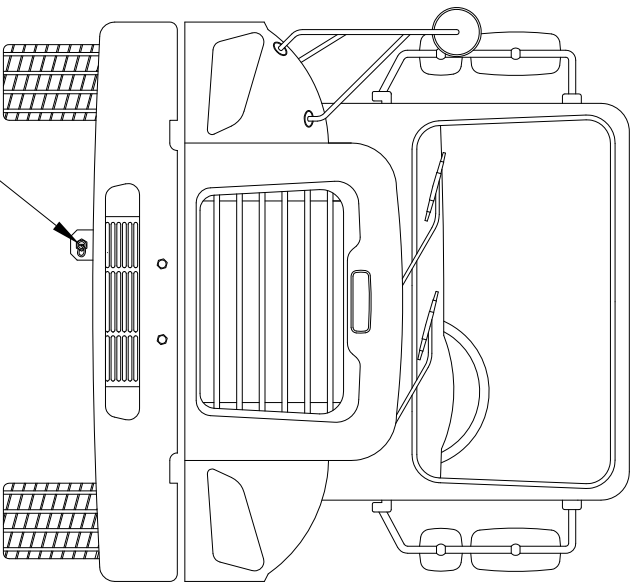
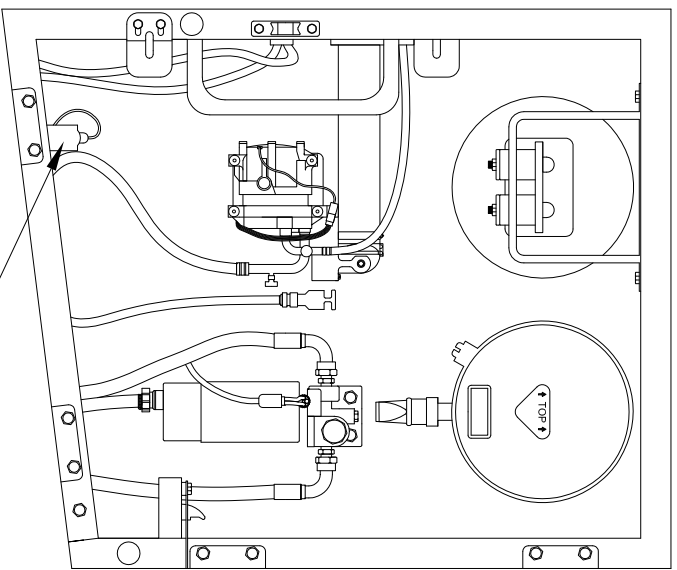

DISCONNECT  
COUPLING  
FLOCS  
ENGINE KIT

**PA DEPARTMENT OF TRANSPORTATION**

**REVISIONS**

NO.	DATE	BY	SCALE
1	07-01-03	BLD	N/A
2	10-20-06	CJW	N/A
3	06-19-13	JFM	N/A

**FAST LUBE OIL CHANGE SYSTEM  
OVERVIEW AND PARTS LIST**

NO.	DATE	BY	SCALE
1	07-01-03	BLD	N/A
2	10-20-06	CJW	N/A
3	06-19-13	JFM	N/A

000-0000



1. CONTACT AEROQUIP WITH YOUR DRAIN PAN PLUG SIZE
2. AEROQUIP DEALER TELEPHONE NUMBERS:

ADVANCED FLUID CONNECTORS..... 717-757-1068  
 AIR BRAKE & POWER EQUIPMENT CO.. 717-622-6188  
 AMERICAN BEARING & POWER..... 717-569-3291  
 GOODALL RUBBER COMPANY ..... 610-534-2100  
 POWER DRIVES INC..... 814-833-8181  
 R L MILLER INC..... 412-833-6800  
 R L MILLER INC..... 814-456-8900  
 SRG/BEVCO..... 610-358-3100  
 VOTO MANUFACTURERS SALES CO.... 814-226-7101

FLOCS SHALL INCLUDE, BUT NOT LIMITED TO:

- A. DUST CAP 5657-12
- B. HOSE TO SUIT LENGTH
- C. HOSE FITTING TO SUIT
- D. ADAPTER TO SUIT
- E. HOSE CLAMP #900729-6
- F. BRACKET TO SUIT
- G. COUPLING 5602-12-12S

PA DEPARTMENT OF TRANSPORTATION

REVISIONS			FAST LUBE OIL CHANGE SYSTEM OVERVIEW AND PARTS LIST		
NO	DATE	BY	SCALE	CHK'D BY	
1	07-01-03	BLD	DLW	N/A	EQN-351A
2	10-20-06	CJW			
3	06-19-13	JFM			

## **SPECIFICATIONS – PART 1**

**CONTRACT SCOPE/OVERVIEW:** Any contract resulting from this Commonwealth Bid will cover the requirements of all Commonwealth using agencies for Road Surface Patching Equipment as cited in the Bid Item Sheet.

**ELIGIBILITY:** In order to be eligible for award, a bidder must comply with the following:

- 1) A bidder must be the manufacturer of the products being offered or an authorized representative (i.e. dealer/reseller) of the manufacturer's products.
  - i. All Bidders who are not OEM's will need to provide written certification from the Original Equipment Manufacturer (OEM) stating that they, the bidder, is an authorized representative (i.e. dealer/reseller) for the OEM's equipment upon which they, the bidder, is bidding on.

Dealers/resellers who fail to provide the letter for any manufacturer's product bid may have their bid rejected.

- 2) Bidders must provide their pricing for the Road Surface Patching Equipment that they are bidding on this IFB by completing and electronically attaching the document entitled "Bid Item Sheet" to their bid. The Bid Item Sheet is an Excel workbook that contains two worksheets for bidders to enter their pricing on - the Base Unit Line Items worksheet and the Optional Equipment and Installation Labor Rate worksheet.

### **Base Unit Line Items:**

- a) Bidder must indicate the Standard Factory Paint Color for the unit on the Bid Item Sheet.
- b) Bidder must provide Unit Pricing for the Unit with the Standard Factory Paint Color on the Bid Item Sheet.
- c) Bidder must also provide Unit Pricing for the Unit with one of the following PennDOT Yellow paint option(s):

**Factory:** Having unit bid painted PennDOT yellow. Reference DUPONT F9885 shade only. Unit shall be painted PennDOT yellow in lieu of the OEM's original color. Using the same process as with OEM paint.

**Aftermarket:** Having unit bid painted PennDOT yellow. Reference DUPONT F9885 shade only. All surfaces shall be properly cleaned and prepared prior to paint. Paint shall be the same quality as factory paint. To include all areas of the machine including interior.

**Optional Equipment and Installation Labor Rate:**

- a) Bidders of Base Unit Line Items are to provide pricing for any Optional Equipment Items and Attachments (OEM or Aftermarket) for the Equipment Categories bid on a percent discount from list price basis.
- b) Any reference which may appear on any price list, to any terms and conditions such as “F.O.B. Shipping Point” or “Prices subject to change”, will not be part of any contract with the successful bidder(s) and will be disregarded by the Commonwealth. All price lists must be identified by name and effective date.
- c) Fill-in your company’s Installation Labor Rate. The “Installation Labor Rate” item is only to be used when an ordering entity wishes to procure an option item requiring installation services AFTER a base unit has been ordered, delivered, and put into service by a prior procurement action.

**SPECIFICATIONS:**

- 1) All items to be provided, against any purchase order from any contract resulting from this bid action, shall be in accordance with:
  - a) The applicable Specifications listed in the Bid Item Sheet.
  - b) Any drawings referenced in the Specifications.
  - c) Pennsylvania Department of General Services, PCID NO. 1075, “*General Requirements for Bidding PennDOT Vehicles/Equipment*”, Eff. 1/29/2020.
- 2) All items to be provided, against any purchase order from any contract resulting from this bid action, shall be new (not remanufactured, reconditioned or used) and latest model year only.
- 3) Manufacturer’s model number changes/revisions will be acceptable during the contract period so long as the unit price for that line item remains the same.

If the pricing cannot be maintained, the subject line item will be terminated from the contract.

**BID ITEM SHEET:**

- 1) Read the Important Notes to Bidders contained in the Bid Item Sheet.
- 2) Bidders may not add any new Equipment Categories or Item Descriptions to those listed on the original Bid Item Sheet. Additionally, Bidders may not modify the names of any of the Equipment Categories or the Item Descriptions listed on the original Bid Item Sheet. If this occurs no award will be made in any such newly created or altered Equipment Category/Item Description and your bid response could be rejected as a conditioned bid.



- 3) **The Bid Item Sheet is an unprotected Excel file and, when completed, it needs to be saved and uploaded to your bid as such. DO NOT scan (PDF) your completed Bid Item Sheet or upload it to your bid in any other file format than Excel.**

**AWARDS:**

Let it be understood that awards of the Base Unit Line Items will be based on the Unit Pricing bid for the Unit with the Standard Factory Paint Color. The Unit Pricing bid for the Unit with the PENNDOT Yellow Paint Option will not be used as a factor in award determinations. However, the Bureau of Procurement will list the Unit Pricing bid for the Unit with the PENNDOT Yellow Paint Option with the bidder's corresponding awarded Line Items.

**Single Award Line Items (Kettles/Kettle Patcher and Field Mix Patching Machines):**

Line Items 10 through 180 as listed in the Bid Item Sheet (with the exception of the Kettle Options - Line Items 150 and 160) will be awarded on a Line Item basis, with a Single Award for any given Line Item being made to the lowest responsible and responsive bidder for that Line Item. **The "Lowest Price" will be based on the Unit Pricing bid for the Unit with the Standard Factory Paint Color.**

Let it be understood that the Unit Prices bid for the Kettle Options (Line Items 150 and 160) will not be used as a factor in award determinations. However, the Bureau of Procurement will list the Kettle Options bid with the corresponding Make and Model of awarded Kettle.

**Multiple Award Line Items (Air Compressors and Asphalt Reheaters):**

Line Items 190 through 230 (Asphalt Reheaters) and Line Items 240 and 250 (Air Compressors) as listed in the Bid Item Sheet will be awarded on a Multiple Award Basis. Multiple Award meaning that all OEM units bid by responsible and responsive bidders may be awarded. However, only a single award will be made to any given manufacturer per Line Item. **The "Lowest Price" will be based on the Unit Pricing bid for the Unit with the Standard Factory Paint Color.**

Let it be understood that awards of the Optional Equipment Items and Attachments (OEM or Aftermarket) and Installation Labor Rate will be made to all responsive and responsible bidders.

**MINIMUM ORDER:** The minimum order qualifying for F.O.B. Destination delivered prices shall be one (1) unit. It is understood that all prices bid and awarded are at FOB DESTINATION delivered pricing which includes all costs for delivery, shipping and handling, set-up, and the required manuals, training, and warranty.

**MANUALS:** The following applicable manuals shall be supplied with each unit delivered:

- 1 – Operator’s
- 1 – Parts
- 1 – Service Manual
- 1 – Engine
- 1 – Transmission (Automatic or Manual)
- 1 – Body and Sub Frame (Parts and Service)
- 1 – Complete set of manuals for any additional items/equipment that was added to the equipment.

The manuals listed shall be OEM publications supplemented with technical manuals for all components as published by sub-vendors/manufacturers.

Parts Manual presented must be relative to “all” items utilized to build these units, with appropriate part numbers.

The manuals cited above shall be delivered with the equipment.

Manuals shall be supplied in paper and on a USB Thumb Drive in PDF format.

**WARRANTY:** To be in accordance with Pennsylvania Department of General Services, PCID NO. 1075, “*General Requirements for Bidding PennDOT Vehicles/Equipment*”, Eff. 1/29/2020, Section E “General Warranty Requirements”, Sub Section 1.A. “Construction Equipment.

**DELIVERY:** All units must be delivered within **120 calendar days** after receipt of the purchase order.

In the event that delivery would be projected to exceed the 120 calendar day time period, the supplier shall notify the ordering agency at which time the ordering agency may make determination to allow delivery time frame extension or to cancel the order. The contractor shall then only proceed with the order after receiving written authorization from the ordering agency.

**ALL DELIVERIES FOR PENNDOT** (regardless of any PennDOT field address shown on the Purchase Order) shall be made FOB Destination to Pennsylvania Department of Transportation, Equipment Division, 17th Street and Arsenal Boulevard, Harrisburg, PA 17120. The successful bidder shall deliver the completed unit(s) at ground level (stacked loads are unacceptable) Delivery shall be in accordance with Pennsylvania Department of General Services, PCID NO. 1075, “*General Requirements for Bidding PennDOT Vehicles/Equipment*”, Eff. 1/29/2020, Section G “Delivery”.

**NON-PENNDOT DELIVERY LOCATION:** Deliveries for all other ordering entities (i.e. Commonwealth Agencies other than PennDOT and for COSTARS Purchasers) shall be FOB Destination to the location stated in the Purchase Order.

**EPA'S TIER 4 EMISSION PRICE ADJUSTMENT:** The EPA Tier 4 emission standards introduce substantial reductions of NOx (for engines above 56 Kw) and PM (above 19 Kw), as well as more stringent HC limits. Because of this mandate an additional price increase may be authorized if major manufacturer environmental laws require changes to engines. Documentation will need to be provided to the Commodity Specialist for the price increase.

**SMALL BUSINESS CONTRACTING PROGRAM:** The Commonwealth, through the Small Business Contracting Program, maintains a strong commitment to providing opportunities for small businesses to compete for prime contracting opportunities with the goal of promoting the economic growth and success of small businesses. Businesses interested in participating as a small business must first register to do business with the Commonwealth and self-certify as a "small business". To self-certify a business must meet each of the following requirements:

- The business must be a for-profit, United States business
- The business must be independently owned
- The business may not be dominant in its field of operation
- The business may not employ more than 100 full-time equivalent employees
- The business may not exceed three-year average gross sales of \$20 million

Small business self-certification, a one-year certification which requires annual renewal, is a prerequisite for verification as a Small Diverse Business. To access the small business application and begin the certification process:

- 1) Go to the PA Supplier Portal and click "Supplier Logon" (call 877-435-7363, option 1, if you do not have you Logon information).
- 2) Enter your user name and password.
- 3) Click "Bidder Tab" > "Enterprise Applications" > "Small & Small Diverse Business Program Application" (contact the Supplier Service Center at (877) 435-7363, option 1, if the Enterprise Applications portal page appears blank or view our application guide for basic troubleshooting for most common obstacles).

**INQUIRIES:** Direct all questions concerning this bid action to:

Lisa Vega  
Telephone: 717-346-4290  
E-mail: [lvega@pa.gov](mailto:lvega@pa.gov)

Manufacturers standard ASPHALT REHEATER, TRAILER MOUNTED, 4 TON STORAGE UNIT To carry asphalt pothole patching material. Designed to be towed at 65 mph maximum for on- road/off-road usage. shall be ordered utilizing the following code/s.

- 037100-** TRAILER, ASPHALT REHEATER, 4 TON STORAGE UNIT, COMBINATION UNIT Defined as standard propane unit with 35 gallon insulated tack/sealant tank, LPG heated, thermostatically controlled.
- 037300-**TRAILER, ASPHALT REHEATER, 4 TON STORAGE UNIT, PROPANE
- 037350-**TRAILER, ASPHALT REHEATER, 4 TON DUMPING STORAGE UNIT, PROPANE,
- 037400-**TRAILER, ASPHALT REHEATER, 4 TON STORAGE UNIT, DIESEL
- 037450** TRAILER, ASPHALT REHEATER, 4 TON DUMPING STORAGE UNIT, DIESEL

**Note: "Refer to PCID 1075 for Delivery, and Warranty Requirements". Warranty Shall be per Section E.1.A.**

**The following additional items shall be supplied**

**Acceptable**

<p>1. PAINT:                  Bidder must indicate the Standard Factory Paint Color for the unit on the Bid Item Sheet.                  Bidder must provide Unit Pricing for the Unit with the Standard Factory Paint Color on the Bid Item Sheet.                  Bidder must also provide Unit Pricing for the Unit with one of the following paint option(s)                  Factory: Having unit bid painted PennDOT yellow. Reference DUPONT F9885 shade only. Unit shall be painted PennDOT yellow in lieu of the OEM's original color. Using the same process as with OEM paint.                  Aftermarket: Having unit bid painted PennDOT yellow. Reference DUPONT F9885 shade only. All surfaces shall be properly cleaned and prepared prior to paint. Paint shall be the same quality as factory paint. To include all areas of the machine including interior.</p>	
<p>Comments</p>	
<p>2. Shall have a Vandalism package: All fill caps such as for fuel, engine oil, hydraulic oil, radiator etc. shall be lockable or located Inside lockable housing cabinet (s). With padlock (s) and key (all locks keyed alike).</p>	
<p>Comments</p>	
<p>3. Lighting shall be per Federal and State regulations for stop, turn, and tail lights. All lights shall be LED. Seven wire trailer cord and connector set to extend to front of hitch inside protective conduit as per ATA wiring sequence. Cable shall extend 8ft beyond pintle eye. REF:EQN80-B. There shall be a Cole Hersee Part # 11750 or equal store-a-way trailer connector plug holder located in the tongue area. REF:EQN-84</p>	
<p>Comments</p>	
<p>4. Fire extinguisher: Fire extinguisher, rechargeable, with vehicle mount. Mounted for easy and quick access, towards rear of machine. 20 lb. 10A:40B:C with weather-proof cover.</p>	
<p>Comments</p>	
<p>5. Surge brake: If the manufacturer deems it necessary to have brakes we require a Surge Brakes System per EQN-84 including break-away safety mechanism. *Note - Trailers that are to be equipped with surge brakes shall rely on a mechanical braking system, the use of electrical connections such as solenoids or dump valves will not be accepted. The axle brake shoes must be "FREE BACKING" type.</p>	
<p>Comments</p>	
<p>6. Hitch Assembly &amp; Safety Chains: Adjustable trailer tongue to accommodate variable truck hitch height levels along with 2 rust proof safety chains that must be at least 4ft long and must extend 3 feet beyond pintle eye. REF:EQN-84</p>	
<p>Comments</p>	
<p>7. Manufacturer standard tool box.</p>	
<p>Comments</p>	
<p>8. Unit shall have wheels properly sized within all requirements and ranges to meet the specification. Wheels shall be a hub piloted, one piece design. Ref: EQN-84 and EQN-80B                  Note: UTG / Donut type wheels (type used in the mobile home industry) are not acceptable.</p>	
<p>Comments</p>	
<p>9. Electrical Power: A 12 volt self contained power source shall be included with unit capable of operating thermostatic burner controls. Power source shall include lockable/enclosed and vented battery box, 12 volt deep cycle battery, 120 volt/12 volt power inverter-trickle charger to allow overnight heating.</p>	

	Page 2 of 2	
10. 1 Pair of Wheel chocks and holder REF:EQN-82A		
Comments		
11. All grab handles and stepping areas shall have anti-slip paint. <b>Non-skid tape is not acceptable.</b>		
Comments		
12. Safety: Unit shall have all applicable decals and safety labels. NOTE: Unit shall have decal or stencil - minimum 3 inches - "HOT" on both sides of unit. . Manufacturer shall install all safety decals, warning labels, guards and devices available as standard equipment on all equipment offered.		
Comments		
13. Dumping hopper: (ECN# 037350 & 037450) Lifting mechanism shall consist of two hydraulic cylinders to push evenly on the hopper. Hopper shall be equipped with a safety prop for holding the hopper in the up position for maintenance. Rear door shall utilize an hydraulic cylinder to open and close the rear door with control box located on the unit.		
Comments		
14. Controls: Flame sensing, thermostatically controlled located in a weather proof lockable cabinet.		
Comments		
15. There shall be a paper Operator, Parts and Maintenance and Repair manuals along with an electronic form of each manual on a USB thumb drive in Adobe PDF format. The paper operators manual shall have a weather resistant holder attached to the unit.		
Comments		
16. TRAINING: There shall be 7Hrs. Start up and & Familiarization Training for operators and mechanics. This shall be completed at the final county location.		
Comments		
17. Warranty period shall be for 2 years, 100% parts & labor. Warranty and delivery per PCID 1075. The warranty start up date shall be defined as the date of transfer from the PennDOT Fleet Management Division to the designated county location. This will be considered the date of delivery to the county and NOT the date of delivery by the successful bidder to the department. The PennDOT Fleet Management will supply the actual start-up date, equipment number, and serial number of the machine, via email, to the successful bidder. It is the responsibility of the successful bidder to ensure that the equipment manufacturer recognizes and applies the Department's actual warranty start-up date in their database.		
Comments		
18. Paper work provided by manufacturer, vendor or carrier company at time of equipment delivery for signature will only be signed for verification of delivery. Signature will not endorse delivered equipment is free of defects or verification that equipment meets specification/quote. Acceptance of equipment is pending through inspection, with equipment meeting the specification/quote. Paper work will not be submitted for payment until all deficiencies are corrected, prior to purchase order delivery deadline.		
Comments		
	1/4/2023 JAH	

**SPECIFICATION 5**

Manufacturer standard double boiler type mixing machine that is designed to heat and melt TECHCRETE-R and TECHCRETE-TBR patching material. Designed to be towed at 65 mph maximum for on-road/off-road use.  
Units shall be ordered utilizing the following equipment code

**018750- PATCHING MACHINE, TRAILER MOUNTED, CRAFCO PATCHER II**

**Note: "Refer to PCID 1075 for Delivery, and Warranty Requirements". Warranty shall be per Section E.1.A.**

The following additional items shall be supplied.	Accepted
<p>1. PAINT: Bidder must indicate the Standard Factory Paint Color for the unit on the Bid Item Sheet. Bidder must provide Unit Pricing for the Unit with the Standard Factory Paint Color on the Bid Item Sheet. Bidder must also provide Unit Pricing for the Unit with one of the following paint option(s) Factory: Having unit bid painted PennDOT yellow. Reference DUPONT F9885 shade only. Unit shall be painted PennDOT yellow in lieu of the OEM's original color. Using the same process as with OEM paint. Aftermarket: Having unit bid painted PennDOT yellow. Reference DUPONT F9885 shade only. All surfaces shall be properly cleaned and prepared prior to paint. Paint shall be the same quality as factory paint. To include all areas of the machine including interior.</p>	
Comments	
2. Shall have an installed FLOCS (Oil Evacuation) system. Ref: EQN-351A.	
Comments	
3. Hour meter shall record only when the engine is running.	
Comments	
4. Shall have a Vandalism package: All fill caps such as for fuel, engine oil, hydraulic oil, radiator etc. shall be lockable or located Inside lockable housing cabinet (s). With padlock (s) and key (all locks keyed alike).	
Comments	
5. Fire extinguisher, 20 LB. 10A:40B:C rechargeable with vehicle mount and weatherproof cover.	
Comments	
6. Lighting shall be per Federal and State regulations for stop, turn and tail lights. All lights shall be LED. Seven wire trailer cord and connector set to extend to front of hitch inside protective conduit as per ATA wiring sequence. Cable shall extend 8ft beyond pintle eye. REF:EQN80-B. There shall be a Cole Hersee Part # 11750 or equal stor-a-way trailer connector plug holder located in the tongue area. REF:EQN-84	
Comments	
7. TRAILER: Ref: EQN-84 and EQN-80B. Unit shall have wheels properly sized within all requirements and ranges to meet the specification. Wheels shall be a hub piloted, one piece design. Note: UTG / Donut type wheels (type used in the mobile home industry) are not acceptable.	
Comments	
8. Surge brake: System per EQN-84 drawing, including break-away safety mechanism, *Note - Trailers that are to be equipped with surge brakes shall rely on a mechanical braking system, the use of electrical connections such as solenoids or dump valves will not be accepted. The axle brake shoes must be "FREE BACKING" type.	
Comments	
9. Hitch height & Safety Chains: Adjustable trailer tongue to accommodate variable truck hitch height levels along with 2 rust proof safety chains that must be at least 4ft long and must extend 3 feet beyond pintle eye. REF:EQN-84	
Comments	
10. All grab handles and stepping areas shall have anti-slip paint. <b>Non-skid tape is not acceptable.</b>	
Comments	
11. 1 Pair of wheel chocks and holder REF:EQN82A	
Comments	

	Page 2
12. All moving parts (e.g. belts, gears, etc.) and hot parts shall be provided with protective guards. Exhaust pipe with muffler shall not be a safety hazard and shall not interfere with operation of the engine. There shall be "HOT" markings on both sides of the Tank (marking imprinted "HOT" and 3257) requirements of 49CFR. Manufacturer shall install all safety decals, warning labels, guards and devices available as standard equipment on all equipment offered.	
Comments	
13. Engine shall be protected from inclement weather. Cover shall be removable to allow engine access. Top shall be solid metal and sides shall be perforated as necessary to allow for proper cooling. Noise Level: Not more than 84dBA measured at 4 foot distance from the center of rear bumper and in a horizontal plane.	
Comments	
14. Minimum 200GAL material tank with a rear discharge with a minimum opening of 42 square inches which will material to drop onto a spout. The material shall be mixed by a hydraulically driven, full sweep, staggered horizontal mixer which the mixer must rotate in both direction.	
Comments	
15. There shall be a removable material chute with a minimum 37inches in length by 8 inches wide by 4 inches in depth to help aid in placement of the material from machine to the road repair.	
Comments	
16. There shall be a 30lb propane bottle and regulator with a 500,000 BTU hand torch with a 20 foot hose. There must be provisions made on the machine to hold the bottle and torch safely.	
Comments	
17. The jacket shall wrap around 100% of the outside area of the material tank including the sides, front, back and bottom and allow for complete circulation of the heated heat transfer oil. A full 200GAL tank of material shall heated and ready to pour in 2 hours.	
Comments	
18 Temperature Controls shall be in a lockable weather proof cabinet. The thermostat shall control burner ignition from the material temperature range from 200 degrees F to 450 degrees F. The heat transfer oil is heated by a 370,000 BTU diesel burner at the bottom of the heat transfer oil tank.	
Comments	
19. There shall be a paper Operator, Parts and Maintenance and Repair manuals along with an electronic form of each manual on a USB thumb drive in Adobe PDF format. The paper operators manual shall have a weather resistant holder attached to the unit.	
Comments	
20. TRAINING: There shall be 7Hrs. Start up and & Familiarization training for operators and mechanics. This shall be completed at the final county location.	
Comments	
21. Warranty period shall be for 2 years, 100% parts & labor. Warranty and delivery per PCID 1075. The warranty start up date shall be defined as the date of transfer from the PennDOT Fleet Management Division to the designated county location. This will be considered the date of delivery to the county and NOT the date of delivery by the successful bidder to the department. The PennDOT Fleet Management will supply the actual start-up date, equipment number, and serial number of the machine, via email, to the successful bidder. It is the responsibility of the successful bidder to ensure that the equipment manufacturer recognizes and applies the Department's actual warranty start-up date in their database.	
Comments	
22. Paper work provided by manufacturer, vendor or carrier company at time of equipment delivery for signature will only be signed for verification of delivery. Signature will not endorse delivered equipment is free of defects or verification that equipment meets specification/quote. Acceptance of equipment is pending through inspection, with equipment meeting the specification/quote. Paper work will not be submitted for payment until all deficiencies are corrected, prior to purchase order delivery deadline.	
Comments	
<b>ONLY UNITS THAT HAVE BEEN EVALUATED AND PRE-APPROVED PRIOR TO BID ENDING DATE WILL BE CONSIDERED IN THIS BID. FOR FUTURE PRE- APPROVAL PLEASE CONTACT THE PENNDOT FLEET MANAGEMENT DIVISION SPECIFICATION UNIT AT 717-787-1567</b>	
	<b>1/4/2023 JAH</b>

SPECIFICATION 4.	Page 1 of 2
Manufacturers standard FIELD MIX PATCHING MACHINE To carry asphalt pothole patching material and accessories, including the swinging overhead hose carrier boom on rear. Designed to be towed at 65 mph maximum for on-road/off-road use. Units shall be ordered utilizing the following equipment code/s.	
<b>018720</b> – PATCHING MACHINE, TRAILER MOUNTED, DURA PATCHER P2 <b>018730</b> – PATCHING MACHINE, TRAILER MOUNTED, CRAFCO MAGNUM	
<b>Note: "Refer to PCID 1075 for Delivery, and Warranty Requirements". Warranty shall be per Section E.1.A.</b>	
The following additional items shall be supplied.	Accepted
<b>1. PAINT:</b> Bidder must indicate the Standard Factory Paint Color for the unit on the Bid Item Sheet. Bidder must provide Unit Pricing for the Unit with the Standard Factory Paint Color on the Bid Item Sheet. Bidder must also provide Unit Pricing for the Unit with one of the following paint option(s) Factory: Having unit bid painted PennDOT yellow. Reference DUPONT F9885 shade only. Unit shall be painted PennDOT yellow in lieu of the OEM's original color. Using the same process as with OEM paint. Aftermarket: Having unit bid painted PennDOT yellow. Reference DUPONT F9885 shade only. All surfaces shall be properly cleaned and prepared prior to paint. Paint shall be the same quality as factory paint. To include all areas of the machine including interior	
Comments	
2. Shall have an installed FLOCS (Oil Evacuation) system. Ref: EQN-351A.	
Comments	
3. Hour meter shall record only when the engine is running.	
Comments	
4. Shall have a Vandalism package: All fill caps such as for fuel, engine oil, hydraulic oil, radiator etc. shall be lockable or located inside lockable housing cabinet (s). With padlock (s) and key (all locks keyed alike).	
Comments	
5. Fire extinguisher, 20 LB. 10A:40B:C rechargeable with vehicle mount and weatherproof cover.	
Comments	
6. Lighting shall be per Federal and State regulations for stop, turn and tail lights. All lights shall be LED. Seven wire trailer cord and connector set to extend to front of hitch inside protective conduit as per ATA wiring sequence. Cable shall extend 8ft beyond pintle eye. REF:EQN80-B. There shall be a Cole Hersee Part # 11750 or equal stor-a-way trailer connector plug holder located in the tongue area. REF:EQN-84	
Comments	
7. Unit shall have wheels properly sized within all requirements and ranges to meet the specification. Wheels shall be a hub piloted, one piece design. Ref: EQN-84 and EQN-80B <b>Note: UTG / Donut type wheels (type used in the mobile home industry) are not acceptable.</b>	
Comments	
8. Surge brake: If the manufacturer deems it necessary to have brakes we require a Surge Brakes System per EQN-84 including break-away safety mechanism. *Note - Trailers that are to be equipped with surge brakes shall rely on a mechanical braking system, the use of electrical connections such as solenoids or dump valves will not be accepted. The axle brake shoes must be "FREE BACKING" type.	
Comments	
9. Hitch height & Safety Chains: Adjustable trailer tongue to accommodate variable truck hitch height levels along with 2 rust proof safety chains that must be at least 4ft long and must extend 3 feet beyond pintle eye. REF:EQN-84	
Comments	
10. All grab handles and stepping areas shall have anti-slip paint. <b>Non-skid tape is not acceptable.</b>	
Comments	
11. 1 Pair of wheel chocks and holder REF:EQN82A	
Comments	
12. <b>Safety Switches:</b> For operator safety, safety switches shall be incorporated to stop the tailgate screw feeder and the pick-up wheel when the protective screen/cover on receiving hopper is lifted/removed or to stop stone delivery and air velocity.	
Comments	



		Page 2
<p>13. All moving parts (e.g. belts, gears, etc.) and hot parts shall be provided with protective guards. Exhaust pipe with muffler shall not be a safety hazard and shall not interfere with operation of the engine. There shall be "HOT" markings on both sides of the Tank (marking imprinted "HOT" and 3257) requirements of 49CFR. Manufacturer shall install all safety decals, warning labels, guards and devices available as standard equipment on all equipment offered.</p>		
Comments		
<p>14. Engine shall be protected from inclement weather. Cover shall be removable to allow engine access. Top shall be solid metal and sides shall be perforated as necessary to allow for proper cooling. Noise Level: Not more than 84dBA measured at 4 foot distance from the center of rear bumper and in a horizontal plane.</p>		
Comments		
<p>15. There shall be a paper Operator, Parts and Maintenance and Repair manuals along with an electronic form of each manual on a USB thumb drive in Adobe PDF format. The paper operators manual shall have a weather resistant holder attached to the unit.</p>		
Comments		
<p>16. There shall be 7Hrs. Start up and &amp; Familiarization training for operators and mechanics. This shall be completed at the final county location.</p>		
Comments		
<p>17 Warranty period shall be for 2 years, 100% parts &amp; labor. Warranty and delivery per PCID 1075. The warranty start up date shall be defined as the date of transfer from the PennDOT Fleet Management Division to the designated county location. This will be considered the date of delivery to the county and NOT the date of delivery by the successful bidder to the department. The PennDOT Fleet Management will supply the actual start-up date, equipment number, and serial number of the machine, via email, to the successful bidder. It is the responsibility of the successful bidder to ensure that the equipment manufacturer recognizes and applies the Department's actual warranty start-up date in their database.</p>		
Comments		
<p>18. Paper work provided by manufacturer, vendor or carrier company at time of equipment delivery for signature will only be signed for verification of delivery. Signature will not endorse delivered equipment is free of defects or verification that equipment meets specification/quote. Acceptance of equipment is pending through inspection, with equipment meeting the specification/quote. Paper work will not be submitted for payment until all deficiencies are corrected, prior to purchase order delivery deadline.</p>		
Comments		
<p><b>ONLY UNITS THAT HAVE BEEN EVALUATED AND PRE-APPROVED PRIOR TO BID ENDING DATE WILL BE CONSIDERED IN THIS BID. FOR FUTURE PRE- APPROVAL PLEASE CONTACT THE PENNDOT FLEET MANAGEMENT DIVISION SPECIFICATION UNIT AT 717-787-1567</b></p>		
		1/4/2022 JAH

Manufacturers standard various sized kettles designed to be towed fully loaded at 65 mph. Units shall be ordered utilizing the following PennDOT Equipment ECN Code/s: 009960 to 011090 Vendors may bid the following manufacturers standard kettles from 100 gallons to 425 gallons using the appropriate code. Unit pricing for all kettles bid is to include a Heated Hose (Electric) as standard equipment. Conveyors and air compressors for kettles may be separate line item options.

**Note: "Refer to PCID 1075 for Delivery, and Warranty Requirements". Warranty Shall be per Section E.1.A.**

- 009970-Cimeline, Magma Series, M1 110
- 010120-Cimeline, Magma Series, M2 230
- 010820-Cimeline, Magma Series, M3 410
- 010000-Crafco, 125 Super Shot
- 010050-Crafco, 250 Super Shot
- 009960-Crafco, EZ series II- 500
- 010110-Crafco, EZ Series II-1000
- 010810-Crafco, EZ Series II-1500
- 009980-Crack Pro, 125
- 010130-Crack Pro, 200
- 010140-Crack Pro. 260
- 010830-Crack Pro, 400
- 010600-Marathon KEB350T

**The following additional items shall be supplied:**

Accepted

1. PAINT:  
 Bidder must indicate the Standard Factory Paint Color for the unit on the Bid Item Sheet.  
 Bidder must provide Unit Pricing for the Unit with the Standard Factory Paint Color on the Bid Item Sheet.  
 Bidder must also provide Unit Pricing for the Unit with one of the following paint option(s)  
 Factory: Having unit bid painted PennDOT yellow. Reference DUPONT F9885 shade only. Unit shall be painted PennDOT yellow in lieu of the OEM's original color. Using the same process as with OEM paint.  
 Aftermarket: Having unit bid painted PennDOT yellow. Reference DUPONT F9885 shade only. All surfaces shall be properly cleaned and prepared prior to paint. Paint shall be the same quality as factory paint. To include all areas of the machine including interior.

Comments

2. Shall have an installed FLOCS (Oil Evacuation) system. Ref: EQN-351A.

Comments

3. Lighting shall be per Federal and State regulations for stop, turn and tail lights. All lights shall be LED. Seven wire trailer cord and connector set to extend to front of hitch inside protective conduit as per ATA wiring sequence. Cable shall extend 8ft beyond pintle eye. REF:EQN80-B. There shall be a Cole Hersee Part # 11750 or equal stor-a-way trailer connector plug holder located in the tongue area. REF:EQN-84

Comments

4. Surge brake: If the manufacturer deems it necessary to have brakes we require a Surge Brakes System per EQN-84 including break-away safety mechanism. \*Note - Trailers that are to be equipped with surge brakes shall rely on a mechanical braking system, the use of electrical connections such as solenoids or dump valves will not be accepted. The axle brake shoes must be "FREE BACKING" type.

Comments

5. Unit shall have wheels properly sized within all requirements and ranges to meet the specification. Wheels shall be a hub piloted, one piece design. Ref: EQN-84 and EQN-80B  
 Note: UTG / Donut type wheels (type used in the mobile home industry) are not acceptable.

Comments

6. Hitch height & Safety Chains: Adjustable trailer tongue to accommodate variable truck hitch height levels along with 2 rust proof safety chains that must be at least 4ft long and must extend 3 feet beyond pintle eye. REF:EQN-84

Comments

7. There shall be grab handles on each side of the unit as a safety measure for the operator, with anti-slip paint. All grab handles and step platforms shall have antiskid paint. **Non-skid tape is not acceptable**

Comments

8. Fire extinguisher, rechargeable, with vehicle mount. Mounted for easy and quick access, towards rear of machine. 20 lb. 10A:40B:C with weather-proof cover.

Comments

		Page 2
9. Manufacturer standard tool box		
Comments		
10. Electric Heated Material Hose.		
Comments		
11. 1 Pair of Wheel chocks and holder REF:EQN-82A		
Comments		
12. Hour meter to work only when engine is running.		
Comments		
13. All moving parts (e.g. belts, gears, etc.) and hot parts shall be provided with protective guards. Exhaust pipe with muffler shall not be a safety hazard and shall not interfere with operation of the engine. There shall be "HOT" markings on both sides of the kettle (marking imprinted "HOT" and 3257) requirements of 49CFR. Manufacturer shall install all safety decals, warning labels, guards and devices available as standard equipment on all equipment offered.		
Comments		
14. Engine shall be protected from inclement weather. Cover shall be removable to allow engine access. Top shall be solid metal and sides shall be perforated as necessary to allow for proper cooling. <b>Noise Level:</b> Not more than 84dBA measured at 4 foot distance from the center of rear bumper and in a horizontal plane 4 feet above the ground with burners in operational condition.		
Comments		
15. Shall have a Vandalism package: All fill caps such as for fuel, engine oil, hydraulic oil, radiator etc. shall be lockable or located Inside lockable housing cabinet (s). With padlock (s) and key (all locks keyed alike).		
Comments		
16. There shall be a paper Operator, Parts and Maintenance and Repair manuals along with an electronic form of each manual on a USB thumb drive in Adobe PDF format. The paper operators manual shall have a weather resistant holder attached to the unit.		
Comments		
17. There shall be 7Hrs. Start up and & Familiarization Training for operators and mechanics. This shall be completed at the final county location.		
Comments		
18. Warranty period shall be for 2 years, 100% parts & labor. Warranty and delivery per PCID 1075. The warranty start up date shall be defined as the date of transfer from the PennDOT Fleet Management Division to the designated county location. This will be considered the date of delivery to the county and NOT the date of delivery by the successful bidder to the department. The PennDOT Fleet Management will supply the actual start-up date, equipment number, and serial number of the machine, via email, to the successful bidder. It is the responsibility of the successful bidder to ensure that the equipment manufacturer recognizes and applies the Department's actual warranty start-up date in their database.		
Comments		
19. Paper work provided by manufacturer, vendor or carrier company at time of equipment delivery for signature will only be signed for verification of delivery. Signature will not endorse delivered equipment is free of defects or verification that equipment meets specification/quote. Acceptance of equipment is pending through inspection, with equipment meeting the specification/quote. Paper work will not be submitted for payment until all deficiencies are corrected, prior to purchase order delivery deadline.		
Comments		
20. Hatch splash prevention box: A low profile top loading splash prevention box shall be provided at the top of the material tank and located on the curbside of the machine for operator safety. The splash prevention box shall be mounted to the existing melter opening by either stitch weld or bolted in place and will automatically close once the sealant blocks are dropped in.		
Comments		
21. <b>AIR COMPRESSOR: (option)</b> If a unit is ordered with an air compressor it shall be the largest available by the manufacturer but a 70 CFM will be the minimum size compressor that will be accepted and must be included in the option price. <b>Compressor shall be required to maintain a minimum of 100 PSI at tip of nozzle while in use. At no time while in use shall the PSI drop below 100 PSI.</b> The trailer shall be of additional sufficient length and strength to support the tongue weight of the air compressor, drive, and reel assembly. Additional weight shall be compensated for throughout the entire trailer assembly. There shall be an additional hydraulic pump (one for the melter and one for the compressor). There shall be 50 feet of 0.3750 inch I.D., minimum 300 PSI, oil resistant, static non-conductive air hose. The hose shall be placed on a reel assembly (Reelcraft Model 7800 OMS "stainless steel" (Tel. #219-248-8188, or equal), mounted on the roadside. There shall be a trigger pistol grip design to allow for infinite control of output pressure and automatic shut-off when released or if dropped.		
Comments		

**22. Splash prevention box and Conveyor:** (option) If a unit is ordered with a conveyor the following must be included in the option price.

**Conveyor:** There shall be a powered conveyor that runs from the loading hatch over the front of the kettle trailer to the towing vehicle. The conveyor shall have weatherproof operating switches protected by circuit breakers at the vehicle end and at ground level on the curbside of the melter.

The conveyor or loading end controls shall have a momentary "ON" switch, a "FORWARD AND REVERSE" switch and a "EMERGENCY STOP" button. The "ON" switch must be held in the on position to power the conveyor. The "EMERGENCY STOP" button is provided to disable the conveyor. The FORWARD AND REVERSE switch must be switched to which direction you want the conveyor to move then you must hold in the momentary "ON" switch to activate the conveyor.

The curbside (Ground Level) controls shall have a momentary "ON" switch and a "EMERGENCY STOP". The "ON" button is used for dispensing the sealant blocks after the conveyor is fully loaded.

The conveyor is hydraulically driven and controlled by a four-way valve that is activated by an electric solenoid.

**Splash prevention box:** The box will be equipped with a loading tower that will automatically close as the sealant blocks are dropped from the conveyor. The inner doors shall pivot inside the loading tower and swing closed after the sealant blocks pass. A lid shall be provided on the loading box to be closed when the conveyor and melter are not in use. A handle is attached to the side of the lid for safety. The operator shall be able to open the lid on the splash prevention box without climbing on the melter. A splash prevention box shall have an adjustable mounting plate for the conveyor support. The belt shall be white friction surface butyl material that can withstand temperatures up to 500 degrees F. The belt shall be able to hold weights up to 800 LB.

**ONLY UNITS THAT HAVE BEEN EVALUATED AND PRE-APPROVED PRIOR TO BID ENDING DATE WILL BE CONSIDERED IN THIS BID. FOR FUTURE PRE- APPROVAL PLEASE CONTACT THE PENNDOT FLEET MANAGEMENT DIVISION SPECIFICATION UNIT AT 717-787-1567**



|

Manufacturers standard combination crack sealing and mastic mixer unit must be able to melt crack sealing material for crack sealing application and mix separately aggregate with crack sealing material to create mastic material for an on demand application. This unit must be capable of starting at ambient temperature and bringing all materials (aggregate and sealant) to a mixable temperature in less than 1 hour and capable of placement on the roadway and be a continuous on demand system. Designed to be towed at 65mph maximum for on-road/off road use. Unit shall be ordered utilizing the following equipment code.

**Note: "Refer to PCID 1075 for Delivery, and Warranty Requirements". Warranty Shall be per Section E.1.A.**

009950- CIMLINE C-1 ON DEMAND DUAL UNIT SEALER AND MASTIC APPLICATOR

**The following additional items shall be supplied:**

Accepted

**1. PAINT:**  
 Bidder must indicate the Standard Factory Paint Color for the unit on the Bid Item Sheet.  
 Bidder must provide Unit Pricing for the Unit with the Standard Factory Paint Color on the Bid Item Sheet.  
 Bidder must also provide Unit Pricing for the Unit with one of the following paint option(s)  
 Factory: Having unit bid painted PennDOT yellow. Reference DUPONT F9885 shade only. Unit shall be painted PennDOT yellow in lieu of the OEM's original color. Using the same process as with OEM paint.  
 Aftermarket: Having unit bid painted PennDOT yellow. Reference DUPONT F9885 shade only. All surfaces shall be properly cleaned and prepared prior to paint. Paint shall be the same quality as factory paint. To include all areas of the machine including interior.

Comments

**2. FLOCS:** Quick change oil change system per EQN-351A

Comments

**3.** Lighting shall be per Federal and State regulations for stop, turn and tail lights. All lights shall be LED. Seven wire trailer cord and connector set to extend to front of hitch inside protective conduit as per ATA wiring sequence. Cable shall extend 8ft beyond pintle eye. REF:EQN80-B. There shall be a Cole Hersee Part # 11750 or equal stor-a-way trailer connector plug holder located in the tongue area. REF:EQN-84

Comments

**4.** Surge brake System: per EQN-84 including break-away safety mechanism. \*Note - Trailers that are to be equipped with surge brakes shall rely on a mechanical braking system, the use of electrical connections such as solenoids, dump valves or manual systems will not be accepted. The axle brake shoes must be "FREE BACKING" type.

Comments

**5.** Unit shall have wheels properly sized within all requirements and ranges to meet the specification. Wheels shall be a hub piloted, one piece design. Ref: EQN-84 and EQN-80B  
**Note: UTG / Donut type wheels (type used in the mobile home industry) are not acceptable.**

Comments

**6.** Hitch height & Safety Chains: Adjustable trailer tongue to accommodate variable truck hitch height levels along with 2 rust proof safety chains that must be at least 4ft long and must extend 3 feet beyond pintle eye. REF:EQN-84

Comments

**7.** There shall be grab handles on each side of the unit as a safety measure for the operator, with anti-slip paint. All grab handles and step platforms shall have antiskid paint. **Non-skid tape is not acceptable**

Comments

**8.** Fire extinguisher, rechargeable, with vehicle mount. Mounted for easy and quick access, towards rear of machine. 20 lb. 10A:40B:C with weather-proof cover.

Comments

**9.** Manufacturer standard tool box.

Comments

**10.** Electric Heated Material Hose.

Comments

**11.** 1 Pair of Wheel chocks and holder REF:EQN-82A

Comments

**12.** Hour Meter which operates only when engine is running

Comments

**13.** All moving parts (e.g. belts, gears, etc.) and hot parts shall be provided with protective guards. Exhaust pipe with muffler shall not be a safety hazard and shall not interfere with operation of the engine. There shall be "HOT" markings on both sides of the kettle (marking imprinted "HOT" and 3257) requirements of 49CFR. Manufacturer shall install all safety decals, warning labels, guards and devices available as standard equipment on all equipment offered.

	Page 2
<p>14. <b>Shield:</b> Engine shall be protected from inclement weather. Cover shall be removable to allow engine access. Top shall be solid metal and sides shall be perforated as necessary to allow for proper cooling.  <b>Noise Level:</b> Not more than 84dBA measured at 4 foot distance from the center of rear bumper and in a horizontal plane 4 feet above the ground with burners in operational condition.</p>	
Comments	
<p>15. Shall have a Vandalism package: All fill caps such as for fuel, engine oil, hydraulic oil, radiator etc. shall be lockable or located Inside lockable housing cabinet (s). With padlock (s) and key (all locks keyed alike).</p>	
Comments	
<p>16. Material Tank: Diesel heated material tank must be of a double boiler design and have a minimum compacity of 150gal of working crack sealing material.</p>	
Comments	
<p>17. Aggregate Handling System: The unit must be able to convey uncoated washed aggregate from the stone hopper through the heat chamber and allow the aggregate to be delivered at a minimum temp of 180 degrees Fahrenheit to the Mastic Mixing Chamber.</p>	
Comments	
<p>18. Mastic Mixing &amp; Delivery Chute: The mastic mixing chamber shall be able to produce various forms and flows with the designed consistency dependent upon ambient conditions. Unit shall also have the ability to control the amount of heated liquid sealant that will be mixed with the aggregate and delivered to the heated material chute. The chute shall have the ability to reach the shoulder or center lane of the road with out moving the unit out of its lane</p>	
Comments	
<p>19. There shall be a paper Operator, Parts and Maintenance and Repair manuals along with an electronic form of each manual on a USB thumb drive in Adobe PDF format. The paper operators manual shall have a weather resistant holder attached to the unit.</p>	
Comments	
<p>20. There shall be 7Hrs. Start up and &amp; Familiarization Training for operators and mechanics. This shall be completed at the final county location.</p>	
Comments	
<p>21. Warranty period shall be for 2 years, 100% parts &amp; labor. Warranty and delivery per PCID 1075. The warranty start up date shall be defined as the date of transfer from the PennDOT Fleet Management Division to the designated county location. This will be considered the date of delivery to the county and NOT the date of delivery by the successful bidder to the department. The PennDOT Fleet Managment will supply the actual start-up date, equipment number, and serial number of the machine, via email, to the successful bidder. It is the responsibility of the successful bidder to ensure that the equipment manufacturer recognizes and applies the Department's actual warranty start-up date in their database.</p>	
Comments	
<p>22. Paper work provided by manufacturer, vendor or carrier company at time of equipment delivery for signature will only be signed for verification of delivery. Signature will not endorse delivered equipment is free of defects or verification that equipment meets specification/quote. Acceptance of equipment is pending through inspection, with equipment meeting the specification/quote. Paper work will not be submitted for payment until all deficiencies are corrected, prior to purchase order delivery deadline.</p>	
Comments	
<p>23. <b>Hatch splash prevention box:</b> A low profile top loading splash prevention box shall be provided at the top of the material tank and located on the curbside of the machine for operator safety. The splash prevention box shall be mounted to the existing melter opening by either stitch weld or bolted in place and will automatically close once the sealant blocks are dropped in.</p>	
Comments	



	<b>Page 3</b>
<p><b>24. Splash prevention box and Conveyor:</b> (option) If a unit is ordered with a conveyor the following must be included in the option price.</p> <p><b>Conveyor:</b> There shall be a powered conveyor that runs from the loading hatch over the front of the kettle trailer to the towing vehicle. The conveyor shall have weatherproof operating switches protected by circuit breakers at the vehicle end and at ground level on the curbside of the melter.</p> <p>The conveyor or loading end controls shall have a momentary "ON" switch, a "FORWARD AND REVERSE" switch and a "EMERGENCY STOP" button. The "ON "switch must be held in the on position to power the conveyor. The "EMERGENCY STOP" button is provided to disable the conveyor. The FORWARD AND REVERSE switch must be switched to which direction you want the conveyor to move then you must hold in the momentary "ON" switch to activate the conveyor.</p> <p>The curbside (Ground Level) controls shall have a momentary "ON" switch and a "EMERGENCY STOP". The "ON" button is used for dispensing the sealant blocks after the conveyor is fully loaded.</p> <p>The conveyor is hydraulically driven and controlled by a four-way valve that is activated by an electric solenoid.</p>	
<p><b>Splash prevention box:</b> The box will be equipped with a loading tower that will automatically close as the sealant blocks are dropped from the conveyor. The inner doors shall pivot inside the loading tower and swing closed after the sealant blocks pass. A lid shall be provided on the loading box to be closed when the conveyor and melter are not in use. A handle is attached to the side of the lid for safety. The operator shall be able to open the lid on the splash prevention box without climbing on the melter. A splash prevention box shall have an adjustable mounting plate for the conveyor support.</p> <p>The belt shall be white friction surface butyl material that can withstand temperatures up to 500 degrees F. The belt shall be able to hold weights up to 800 LB.</p>	
<p><b>ONLY UNITS THAT HAVE BEEN EVALUATED AND PRE-APPROVED PRIOR TO BID ENDING DATE WILL BE CONSIDERED IN THIS BID. FOR FUTURE PRE- APPROVAL PLEASE CONTACT THE PENNDOT FLEET MANAGEMENT DIVISION SPECIFICATION UNIT AT 717-787-1567</b></p>	
	<b>1/4/2023 JAH</b>

|

## SPECIFICATION 7

**Manufacturers standard Diesel Powered Air Compressor shall be supplied utilizing the following codes.**

**003750 – Compressor, 375 CFM Minimum, Skid Mounted, 110 Horse Power Engine Minimum.**

**Note: " Refer to PCID 1075 for Delivery, and Warranty Requirements". Warranty shall be per Section E. 1. B.**

**The following additional items shall be supplied**

	Accepted
<p><b>1. PAINT:</b>  Bidder must indicate the Standard Factory Paint Color for the unit on the Bid Item Sheet.  Bidder must provide Unit Pricing for the Unit with the Standard Factory Paint Color on the Bid Item Sheet.  Bidder must also provide Unit Pricing for the Unit with one of the following paint option(s)  Factory: Having unit bid painted PennDOT yellow. Reference DUPONT F9885 shade only. Unit shall be painted PennDOT yellow in lieu of the OEM's original color. Using the same process as with OEM paint.  Aftermarket: Having unit bid painted PennDOT yellow. Reference DUPONT F9885 shade only. All surfaces shall be properly cleaned and prepared prior to paint. Paint shall be the same quality as factory paint. To include all areas of the machine including interior.</p>	
Comments	
2. Supplied equipment shall comply with current EPA regulations for model year supplied. Non-compliant equipment will be rejected.	
Comments	
3. Shall have an installed FLOCS (Oil Evacuation) system. Ref: EQN-351A.	
Comments	
4. Shall have an OSHA dead man valve on each opening.	
Comments	
5. Shall have a Tool lubricator, minimum 1 quart capacity, mounted in line.	
Comments	
6. Shall be equipped with Gauge package to include: Hourmeter (hourmeter shall record only when the engine is running), fuel, voltage, oil pressure, tachometer and air pressure.	
Comments	
7. Shall be skid mounted and capable of being lifted by a forklift via a suitable balanced lifting bail.	
Comments	
8. Shall have a Vandalism package: All fill caps such as for fuel, engine oil, hydraulic oil, radiator etc. shall be lockable or located Inside lockable housing cabinet (s). With padlock (s) and key (all locks keyed alike).	
Comments	
9. Shall be equipped with a Safety valve that shall react instantly (shutdown) and automatically, for hose failure or accidental uncoupling which eliminates the possibility of dangerous hose whiplash.	
Comments	
10. All moving parts (e.g. belts, gears, etc.) and hot parts shall be provided with protective guards. Manufacturer shall install all safety decals, warning labels, guards and devices available as standard equipment on all equipment offered.	
Comments	
11. There shall be a paper Operator, Parts and Maintenance and Repair manuals along with an electronic form of each manual on a USB thumb drive in Adobe PDF format. The paper operators manual shall have a weather resistant holder attached to the unit.	
Comments	
12. There shall be 7Hrs. Start up and & Familiarization training for operators and mechanics. This shall be completed at the final county location.	
Comments	

13. Warranty period shall be for 2 years, 100% parts & labor. Warranty and delivery per PCID 1075. The warranty start up date shall be defined as the date of transfer from the PennDOT Fleet Management Division to the designated county location. This will be considered the date of delivery to the county and NOT the date of delivery by the successful bidder to the department. The PennDOT Fleet Management will supply the actual start-up date, equipment number, and serial number of the machine, via email, to the successful bidder. It is the responsibility of the successful bidder to ensure that the equipment manufacturer recognizes and applies the Department's actual warranty start-up date in their database.

Comments

14. Paper work provided by manufacturer, vendor or carrier company at time of equipment delivery for signature will only be signed for verification of delivery. Signature will not endorse delivered equipment is free of defects or verification that equipment meets specification/quote. Acceptance of equipment is pending through inspection, with equipment meeting the specification/quote. Paper work will not be submitted for payment until all deficiencies are corrected, prior to purchase order delivery deadline.

Comments

## SPECIFICATION 1.

Manufacturers standard Diesel Powered, Air Compressor shall be supplied utilizing the following codes.

003500 – Compressor, 185 CFM Minimum, Trailer Mounted

Note: " Refer to PCID 1075 for Delivery, and Warranty Requirements". Warranty shall be per Section E. 1. A.

The following additional items shall be supplied

	Accepted
<p><b>1. PAINT:</b> Bidder must indicate the Standard Factory Paint Color for the unit on the Bid Item Sheet. Bidder must provide Unit Pricing for the Unit with the Standard Factory Paint Color on the Bid Item Sheet. Bidder must also provide Unit Pricing for the Unit with one of the following paint option(s) <b>Factory:</b> Having unit bid painted PennDOT yellow. Reference DUPONT F9885 shade only. Unit shall be painted PennDOT yellow in lieu of the OEM's original color. Using the same process as with OEM paint. <b>Aftermarket:</b> Having unit bid painted PennDOT yellow. Reference DUPONT F9885 shade only. All surfaces shall be properly cleaned and prepared prior to paint. Paint shall be the same quality as factory paint. To include all areas of the machine including interior.</p>	
<b>Comments</b>	
2. Supplied equipment shall comply with current EPA regulations for model year supplied. Non-compliant equipment will be rejected.	
<b>Comments</b>	
3. Shall have an installed FLOCS (Oil Evacuation) system. Ref: EQN-351A.	
<b>Comments</b>	
4. Shall have an OSHA dead man valve on each opening.	
<b>Comments</b>	
5. Shall have a Tool lubricator, minimum 1 quart capacity, mounted in line.	
<b>Comments</b>	
6. Shall be equipped with Gauge package to include: Hourmeter (hourmeter shall record only when the engine is running), fuel, voltage, oil pressure, tachometer and air pressure.	
<b>Comments</b>	
7. Reels: Two (2) 50 feet live hose reels mounted on the top or side of the cabinet or the frame facing rearward. Hoses routed over top of compressor for easy access at the rear of machine. REF: EQN-143	
<b>Comments</b>	
8. THOR hose couplings on hose ends that are compatible with the breaker quick coupler half, with locking sleeves. One THOR coupler mounted on the tongue to serve as a holder to keep two (2) hose ends in place	
<b>Comments</b>	
9. Tool box/s with a capacity for two (2) large silenced breakers and one (1) air tamper.	
<b>Comments</b>	
10. Shall have a Vandalism package: All fill caps such as for fuel, engine oil, hydraulic oil, radiator etc. shall be lockable or located inside lockable housing cabinet (s). With padlock (s) and key (all locks keyed alike).	
<b>Comments</b>	
11. There shall be a safety valve that shall react instantly (shutdown) and automatically, for hose failure or accidental uncoupling which eliminates the possibility of dangerous hose whiplash.	
<b>Comments</b>	
12. The compressor, engine, accessories and housing shall be mounted on the trailer. The unit shall have a heavy duty rear bumper. The bumper shall be as wide as the compressor cabinet.	
<b>Comments</b>	

	Page 2
<p>13. Lighting shall be per Federal and State regulations for stop, turn and tail lights. All lights shall be LED. Seven wire trailer cord and connector set to extend to front of hitch inside protective conduit as per ATA wiring sequence. Cable shall extend 8ft beyond pintle eye. REF:EQN80-B. There shall be a Cole Hersee Part # 11750 or equal stor-a-way trailer connector plug holder located in the tongue area. REF:EQN-84</p>	
<p><b>Comments</b></p>	
<p>14. Unit shall have wheels properly sized within all requirements and ranges to meet the specification. Wheels shall be a hub piloted, one piece design. Ref: EQN-84 and EQN-80B  <b>Note: UTG / Donut type wheels (type used in the mobile home industry) are not acceptable.</b></p>	
<p><b>Comments</b></p>	
<p>15. 1 Pair of Wheel chocks and holder. REF:EQN-82A</p>	
<p><b>Comments</b></p>	
<p>16. Surge brake: If the manufacturer deems it necessary to have brakes we require a Surge Brakes System per EQN-84 including break-away safety mechanism. *Note - Trailers that are to be equipped with surge brakes shall rely on a mechanical braking system, the use of electrical connections such as solenoids or dump valves will not be accepted. The axle brake shoes must be "FREE BACKING" type.</p>	
<p><b>Comments</b></p>	
<p>17. Fire Extinguisher 5LB 3A40BC type rechargeable with vehicle mount and weather proof cover.</p>	
<p><b>Comments</b></p>	
<p>18. All moving parts (e.g. belts, gears, etc.) and hot parts shall be provided with protective guards. Exhaust pipe with muffler shall not be a safety hazard and shall not interfere with operation of the engine. Manufacturer shall install all safety decals, warning labels, guards and devices available as standard equipment on all equipment offered.</p>	
<p><b>Comments</b></p>	
<p>19. Hitch height &amp; Safety Chains: Adjustable trailer tongue to accommodate variable truck hitch height levels along with 2 rust proof safety chains that must be at least 4ft long and must extend 3 feet beyond pintle eye. REF:EQN-84</p>	
<p><b>Comments</b></p>	
<p>20. Warranty period shall be for 2 years, 100% parts &amp; labor. Warranty and delivery per PCID 1075. The warranty start up date shall be defined as the date of transfer from the PennDOT Fleet Management Division to the designated county location. This will be considered the date of delivery to the county and NOT the date of delivery by the successful bidder to the department. The PennDOT Fleet Management will supply the actual start-up date, equipment number, and serial number of the machine, via email, to the successful bidder. It is the responsibility of the successful bidder to ensure that the equipment manufacturer recognizes and applies the Department's actual warranty start-up date in their database.</p>	
<p><b>Comments</b></p>	
<p>21. There shall be a paper Operator, Parts and Maintenance and Repair manuals along with an electronic form of each manual on a USB thumb drive in Adobe PDF format. The paper operators manual shall have a weather resistant holder attached to the unit.</p>	
<p><b>Comments</b></p>	
<p>22. Paper work provided by manufacturer, vendor or carrier company at time of equipment delivery for signature will only be signed for verification of delivery. Signature will not endorse delivered equipment is free of defects or verification that equipment meets specification/quote. Acceptance of equipment is pending through inspection, with equipment meeting the specification/quote. Paper work will not be submitted for payment until all deficiencies are corrected, prior to purchase order delivery deadline.</p>	
<p><b>Comments</b></p>	
<p>23. There shall be 7Hrs. Start up and &amp; Familiarization training for operators and mechanics. This shall be completed at the final county location.</p>	
<p><b>Comments</b></p>	<p>1/4/2023 JAH</p>

Table of Contents

PART I - GENERAL INFORMATION .....	3
I.1 IFB-001.1 Purpose (Oct 2006) .....	3
I.2 IFB-005.1 Type of Contract (Oct. 2006) .....	3
I.3 IFB-008.1C No Pre-bid Conference (Oct. 2006) .....	3
I.4 IFB-009.1 Questions (February 2012).....	3
I.5 IFB-010.1 Addenda to the IFB (Oct. 2006).....	3
I.6 IFB-011.1B Submission of Bids – Electronic Submittal (May 2011).....	3
I.7 IFB-024.1 Bid Protest Procedure (April 2016) .....	4
I.8 IFB-025.1 Electronic Version of this IFB (Oct 2006).....	4
I.9 IFB-027.1 COSTARS Program (January 2017).....	4
I.10 IFB-028.1 Participating Addendum with an External Procurement Activity (Dec 6 2006) .....	7
I.11 IFB-029.1 Prices (Dec 6 2006).....	8
I.12 IFB-030.1 Approved Equal (Nov 2006).....	8
I.13 IFB-031.1 Alternates (Oct 2013).....	8
I.14 IFB-032.1 New Equipment (Nov 2006).....	9
I.15 I-IFB-033.1 Modification or Withdrawal of Bid (Nov 2006) .....	9
I.16 I-IFB-034.1 Rejection of Bids (Nov 2006) .....	10
I.17 Submission-001.1 Representations and Authorizations (February 2017).....	10
PART II - REQUIREMENTS .....	12
II.1 IFB-006.1b COSTARS Program Election to Participate (July 2012).....	12
II.2 II-IFB-008.1b Lobbying Certification and Disclosure – Electronic Submission. (Oct 2006).....	12
II.3 IFB-010.1 License Required (Oct 2013).....	12
II.4 IFB-011.1 Authorized Dealer/Franchiser (Oct 2006) .....	12
II.5 II-IFB-016.1 Post-Submission Descriptive Literature (Dec 2006) .....	12
II.6 II-IFB-017.1b Reciprocal Limitations Act – Electronic Submittal (February 2007).....	13
II.7 II-IFB-018.1b Iran Free Procurement Certification and Disclosure – Electronic Submittal (November 2016).....	13
PART III - SELECTION CRITERIA.....	14
III.1 III-IFB-001.1a Mandatory Responsiveness Requirements (Oct 2006) .....	14
III.2 III-IFB-006.1f Method of Award - All Bidders (April 2011).....	14
III.3 III-IFB-007.1 Awards (May 2011) .....	14
III.4 III-IFB-008.1 Tie Bids (Nov 2006) .....	14
III.5 III-IFB-009.1 Prompt Payment Discounts (Nov 2006) .....	14
III.6 III-IFB-010.1 Option for Separate Competitive Bidding Procedure (Nov 2006).....	14
III.7 III-IFB-014.1 Rebates (Nov 2006) .....	14
PART IV - WORK STATEMENT.....	16
IV.1 IFB-001.1a Specifications (Nov 2006).....	16
PART V - CONTRACT TERMS and CONDITIONS .....	17
V.1 CONTRACT-001.1b Contract Terms and Conditions (Nov 30, 2006).....	17
V.2 CONTRACT-002.1a Term of Contract – Contract (May 2012) .....	17
V.3 CONTRACT-002.2b Renewal of Contract Term – Mutual (Oct 2013).....	17
V.4 CONTRACT-002.3 Extension of Contract Term (Nov 30 2006) .....	17
V.5 CONTRACT-003.1a Signatures – Contract (July 2015).....	17
V.6 CONTRACT-004.1a Definitions (Oct 2013).....	18
V.7 CONTRACT-005.1c Purchase Orders - Vehicles (July 2015).....	18
V.8 CONTRACT-006.1 Independent Prime Contractor (Oct 2006).....	19
V.9 CONTRACT-007.01c Delivery – Vehicles (Oct 2013).....	19
V.10 CONTRACT-007.02 Estimated Quantities (Nov 30 2006).....	19
V.11 CONTRACT-008.1a Warranty. (Oct 2006) .....	19
V.12 CONTRACT-009.1c Patent, Copyright, and Trademark Indemnity (Oct 2013).....	19
V.13 CONTRACT-009.1d Ownership Rights (Oct 2006) .....	20
V.14 CONTRACT-010.1a Acceptance (Oct 2006).....	20
V.15 CONTRACT-010.2 Product Conformance (March 2012) .....	21
V.16 CONTRACT-010.3 Rejected Material Not Considered Abandoned (March 2012) .....	21
V.17 CONTRACT-011.1a Compliance With Law (Oct 2006) .....	21
V.18 CONTRACT-013.1 Environmental Provisions (Oct 2006).....	21
V.19 CONTRACT-014.1 Post-Consumer Recycled Content (June 2016).....	21

V.20 CONTRACT-014.3 Recycled Content Enforcement (February 2012)	22
V.21 CONTRACT-015.1 Compensation (Oct 2006)	22
V.22 CONTRACT-015.2 Billing Requirements (July 2021)	22
V.23 CONTRACT-016.1 Payment (Oct 2006)	22
V.24 CONTRACT-016.2 Payment – Electronic Funds Transfer (July 2022)	23
V.25 CONTRACT-017.1 Taxes (Dec 5 2006)	23
V.26 CONTRACT-018.1 Assignment of Antitrust Claims (Oct 2006)	23
V.27 CONTRACT-019.1 Hold Harmless Provision (Nov 30 2006)	23
V.28 CONTRACT-020.1 Audit Provisions (Oct 2006)	24
V.29 CONTRACT-021.1 Default (Oct 2013)	24
V.30 CONTRACT-022.1 Force Majeure (Oct 2006)	25
V.31 CONTRACT-023.1a Termination Provisions (Oct 2013)	25
V.32 CONTRACT-024.1 Contract Controversies (Oct 2011)	26
V.33 CONTRACT-025.1 Assignability and Subcontracting (Oct 2013)	26
V.34 CONTRACT-026.1 Other Contractors (Oct 2006)	27
V.35 CONTRACT-027.1 Nondiscrimination/Sexual Harassment Clause (August 2018)	27
V.36 CONTRACT-028.1 Contractor Integrity Provisions (January 2015)	28
V.37 CONTRACT-029.1 Contractor Responsibility Provisions (July 2021)	31
V.38 CONTRACT-030.1 Americans with Disabilities Act (July 2021)	31
V.39 CONTRACT-031.1 Hazardous Substances (April 2017)	32
V.40 CONTRACT-032.1 Covenant Against Contingent Fees (Oct 2006)	33
V.41 CONTRACT-033.1 Applicable Law (Oct 2006)	33
V.42 CONTRACT- 034.1b Integration (Nov 30 2006)	33
V.43 CONTRACT-034.2b Order of Precedence - IFB (Dec 6 2006)	34
V.44 CONTRACT-034.3 Controlling Terms and Conditions (Aug 2011)	34
V.45 CONTRACT-035.1a Changes (Oct 2006)	34
V.46 CONTRACT-037.1a Confidentiality (Oct 2013)	34
V.47 CONTRACT-046.1 Manufacturer’s Price Reduction (Oct 2006)	35
V.48 CONTRACT-047.1 Motor Vehicles to be manufactured in North America (Oct 2006)	35
V.49 CONTRACT-047.2b General Delivery Requirements for Vehicles (Oct 2012)	36
V.50 CONTRACT-047.5 Local Public Procurement Unit Participation (March 5, 2007)	36
V.51 CONTRACT-047.6 Additional Delivery Charges (Participating Local Public Procurement Units ONLY) (Oct 2006)	36
V.52 CONTRACT-047.7 Taxes (Oct 2006)	36
V.53 CONTRACT-051.1 Notice (Dec 2006)	36
V.54 CONTRACT-052.1 Right to Know Law (Feb 2010)	36



## **PART I - GENERAL INFORMATION**

### **PART I - GENERAL INFORMATION**

#### **I.1 IFB-001.1 Purpose (Oct 2006)**

The Commonwealth of Pennsylvania (Commonwealth) is issuing this Invitation for Bids (IFB) to meet the needs of DEPARTMENT OF PENNDOT to satisfy a need for Road Service Patching Equipment.

#### **I.2 IFB-005.1 Type of Contract (Oct. 2006)**

If the Issuing Office enters into a contract as a result of this IFB, it will be a contract containing the Contract Terms and Conditions as shown in Part V of this IFB.

#### **I.3 IFB-008.1C No Pre-bid Conference (Oct. 2006)**

There will be no pre-bid conference for this IFB. If there are any questions, please forward them to the Issuing Office prior to the bid opening date and time.

#### **I.4 IFB-009.1 Questions (February 2012)**

All questions regarding the IFB must be submitted in writing to the email address of the Issuing Officer provided in the solicitation. While there is no set timeline for the submittal of questions, questions received within 48 hours prior to the bid due date and time will be answered at the discretion of the Commonwealth. All questions received will be answered, in writing, and such responses shall be posted to eMarketplace as an addendum to the IFB. The Issuing Officer shall not be bound by any verbal information nor shall it be bound by any written information that is not either contained within the IFB or formally issued as an addendum by the Issuing Office. The Issuing Office does not consider questions to be a protest of the specifications or of the solicitation.

#### **I.5 IFB-010.1 Addenda to the IFB (Oct. 2006)**

If the Issuing Office deems it necessary to revise any part of this IFB before the bid response date, the Issuing Office will post an addendum to its website at [WWW.DGS.STATE.PA.US](http://WWW.DGS.STATE.PA.US) it is the Bidder's responsibility to periodically check the website for any new information or addenda to the IFB.

#### **I.6 IFB-011.1B Submission of Bids – Electronic Submittal (May 2011)**

- a. Bids are requested for the item(s) described in the Invitation For Bids and all the documents referenced in the form (collectively called the IFB). Bidders must submit their bids through the Commonwealth's electronic system (SRM).
- b. It is the responsibility of each bidder to ensure that its Bid is received through the electronic system prior to the date and time set for the opening of bids ("Bid Opening Time"). No Bid shall be considered if it arrives after the Bid Opening Time, regardless of reason for the late arrival.

Bids that are timely received prior to the Bid Opening Time shall be opened publicly in the presence of one or more witnesses at the time and place designated in this IFB for the Bid opening.

- c. Bids must be firm. If a Bid is submitted with conditions or exceptions or not in conformance with the terms

and conditions referenced in the IFB Form, it shall be rejected. The Bid shall also be rejected if the items offered by the Bidder are not in conformance with the specifications as determined by the Commonwealth.

d. The Bidder, intending to be legally bound hereby, offers and agrees, if this Bid is accepted, to provide the awarded items at the price(s) set forth in this Bid at the time(s) and place(s) specified.

#### **I.7 IFB-024.1 Bid Protest Procedure (April 2016)**

The Bid Protest Procedure is on the DGS website at

<http://www.dgs.pa.gov/Documents/Procurement%20Forms/Handbook/Pt1/Pt%20I%20Ch%2058%20Bid%20Protests.pdf>

#### **I.8 IFB-025.1 Electronic Version of this IFB (Oct 2006)**

This IFB is being made available by electronic means. If a Bidder electronically accepts the IFB, the Bidder acknowledges and accepts full responsibility to insure that no changes are made to the IFB. In the event of a conflict between a version of the IFB in the Bidder's possession and the Issuing Office's version of the IFB, the Issuing Office's version shall govern.

#### **I.9 IFB-027.1 COSTARS Program (January 2017)**

**COSTARS Purchasers.** Section 1902 of the Commonwealth Procurement Code, 62 Pa.C.S. § 1902 (“Section 1902”), authorizes local public procurement units and state-affiliated entities (together, “COSTARS Members”) to participate in Commonwealth procurement contracts that the Department of General Services (“DGS”) may choose to make available to COSTARS Members. DGS has identified this Contract as one which will be made available for COSTARS Members’ participation.

A. Only those entities registered with DGS are authorized to participate as COSTARS Members in this Contract. A COSTARS Member may be either a local public procurement unit or a state-affiliated entity.

1. A “local public procurement unit” is:

- Any political subdivision (local government unit), such as a municipality, school district, or commission;
- Any public authority (including authorities formed under the Municipality Authorities Act of 1955 or other authorizing legislation, such as the Public Transportation Law or the Aviation Code);
- Any tax-exempt, nonprofit educational institution or organization;
- Any tax-exempt, nonprofit public health institution or organization;
- Any nonprofit fire, rescue, or ambulance company; and
- Any other entity that spends public funds for the procurement of supplies, services, and construction (such as a council of governments, an area government, or an organization that receives public grant funds).

The Department reserves the right to review and determine eligible applicants as Local Public Procurement Units on a case-by-case basis.

2. A state-affiliated entity is a Commonwealth authority or other Commonwealth entity that is not a Commonwealth agency. The term includes:

- The Pennsylvania Turnpike Commission;
- The Pennsylvania Housing Finance Agency;
- The Pennsylvania Municipal Retirement System;
- The Pennsylvania Infrastructure Investment Authority;
- The State Public School Building Authority;

- The Pennsylvania Higher Education Facilities Authority, and
- The State System of Higher Education.

The COSTARS Program is not available for use by Executive Agencies and Independent Agencies as defined by the Commonwealth Procurement Code, or any agency or entity using funds appropriated to the Department of General Services through Capital Budget Project Itemization legislation for the procurement of furniture, fixtures, and equipment.

3. A complete list of local public procurement units and state-affiliated entities that have registered with DGS and that are authorized to procure items from the Contract can be found at <http://www.costars.state.pa.us/SearchCOMember.aspx>

B. COSTARS Members have the option to purchase from this Contract, from any DGS contract established exclusively for COSTARS Members in accordance with the requirements of Section 1902, from any other cooperative procurement contracts, or from their own procurement contracts established in accordance with the applicable laws governing such procurements. The Contractor understands and acknowledges that there is no guarantee that a COSTARS Member will place an order under this Contract, and that the decision to procure from this Contract is within the sole discretion of each COSTARS Member.

C. DGS is acting as a facilitator for COSTARS Members who may wish to purchase under this Contract. COSTARS Members that participate in this Contract and issue purchase orders (“POs”) to Contractors are third party beneficiaries who have the right to sue and be sued for breach of this Contract without joining the Commonwealth or DGS as a party. The Commonwealth will not intervene in any action between a Contractor and a COSTARS Member unless substantial interests of the Commonwealth are involved.

D. COSTARS Members electing to participate in this Contract will order items directly from the Contractor and be responsible for payment directly to the Contractor.

E. Those Contractors electing to permit COSTARS Members to procure from this Contract shall pay the Required Administrative Fee applicable to the Contractor’s classification:

<b>Contractor Classification</b>	<b>Required Administrative Fee</b>
DGS-verified Small Diverse Business Bidder	\$166
DGS Self-Certified Small Business Bidder	\$500
All Other Bidders	\$1,500

1. Each bidder electing to permit COSTARS Members to participate in the Contract must submit the COSTARS Program Election to Participate form with its bid submittal and pay the applicable Administrative Fee upon Contract award in order to sell the awarded items/services to COSTARS Members. If the bidder is a Department of General Services Self-Certified Small Business or Department of General Services-verified Small Diverse Business, a copy of its active Small Business Contracting Program certificate must be included with the bid submittal.

2. At the beginning of each Contract year and upon any Contract renewal, the Contractor shall submit a check for the required amount, payable to “Commonwealth of PA”. The Contractor must pay the Administrative Fee at each contract renewal date to continue to sell the awarded items/services to COSTARS Members.

F. DGS has registered the COSTARS name and logo (together, the “COSTARS Brand”) as a trademark with the Pennsylvania Department of State. Therefore, the Contractor may use the COSTARS Brand only as permitted under in this Subsection.

1. The Contractor shall pay the Administrative Fee covering its participation in the program, including without limitation any use of the COSTARS Brand, for each year of the Contract period. The fee is payable upon Contract

award and prior to the renewal date for each succeeding Contract period.

2. DGS grants the Contractor a nonexclusive license to use the COSTARS Brand, subject to the following conditions:

a. The Contractor agrees not to transfer to any third party, including without limitation any of its subcontractors or suppliers, any privileges it may have to use the COSTARS Brand under this Contract.

b. The Contractor agrees not to use the COSTARS Brand to represent or imply any Commonwealth endorsement or approval of its products or services.

c. The Contractor is permitted to use the COSTARS Brand in broadcast, or Internet media solely in connection with this Contract and any other Contract with the Commonwealth under which it has agreed to make sales to COSTARS Purchasers. The Contractor may use the COSTARS Brand on business cards, brochures, and other print publications so long as the purpose is to identify the Contractor as a COSTARS vendor, and only so long as the required Contract fee is kept current.

d. Should this Contract terminate for any reason, the Contractor agrees promptly to remove the COSTARS Brand from any and all print and electronic media and to refrain from using the COSTARS Brand for any purpose whatsoever from the date of Contract termination forward.

e. The Contractor agrees to defend, indemnify, and hold harmless the Commonwealth of Pennsylvania and DGS from and against all claims, demands, liabilities, obligations, costs, and expenses of any nature whatsoever arising out of or based upon the Contractor's use of the COSTARS Brand.

f. The Contractor agrees it has no property rights in the use of the COSTARS Brand by virtue of this nonexclusive license. The Contractor expressly waives any claims, including without limitation due process claims that may otherwise be available under the law in the event of any dispute involving these terms of use.

G. The Contractor shall furnish to the DGS COSTARS Program Office a quarterly electronic Contract sales report detailing the previous quarter's Contract purchasing activity, using the form and in the format prescribed by DGS. The Contractor shall submit its completed quarterly report no later than the fifteenth calendar day of the succeeding Contract quarter.

1. The Contractor shall submit the reports through the web-based COSTARS Suppliers' Gateway of the PA Supplier Portal at <https://pasupplierportal.state.pa.us/irj/portal/anonymous> , Enterprise Applications. If a Contractor does not have access to the Internet, the Contractor shall send the reports, using the form and in the format prescribed by DGS, on compact disc via US Postal Service to the DGS COSTARS Program Office, Bureau of Procurement, 6th Floor Forum Place, 555 Walnut Street, Harrisburg, PA 17101-1914.

2. For each PO received, the Contractor shall include on the report the name and address of each COSTARS-Registered Purchaser that has used the Contract along with the sales date, and dollar volume of sales to the specific Purchaser for the reporting period.

3. DGS may suspend the Contractor's participation in the COSTARS Program for failure to provide the Quarterly Sales Report within the specified time.

H. Additional information regarding the COSTARS Program is available on the DGS COSTARS Website at [www.costars.state.pa.us](http://www.costars.state.pa.us) .

1. If the Contractor is aware of any qualified entity not currently registered and wishing to participate in the COSTARS Program, please refer the potential purchaser to the DGS COSTARS Website at [www.costars.state.pa.us](http://www.costars.state.pa.us) , where it may register by completing the online

registration form and receiving DGS confirmation of its registration. To view a list of currently-registered COSTARS member entities, please visit the COSTARS website.

2. Direct all questions concerning the COSTARS Program to:

Department of General Services  
COSTARS Program  
555 Walnut Street, 6th Floor  
Harrisburg, PA 17101  
Telephone: 1-866-768-7827  
E-mail [GS-PACostars@pa.gov](mailto:GS-PACostars@pa.gov)

**I.10 IFB-028.1 Participating Addendum with an External Procurement Activity (Dec 6 2006)**

Section 1902 of the *Commonwealth Procurement Code*, 62 Pa.C.S. Section 1902, permits external procurement activities to participate in cooperative purchasing agreements for the procurement of services, supplies or construction.

a. **Definitions.** The following words and phrases have the meanings set forth in this provision:

- 1) *External procurement activity:* The term, as defined in 62 Pa. C. S. Section 1901, means a 'buying organization not located in the Commonwealth [of Pennsylvania] which if located in this Commonwealth would qualify as a public procurement unit [under 62 Pa. C.S. Section 1901]. An agency of the United States is an external procurement activity.'
- 2) *Participating addendum:* A bilateral agreement executed by the Contractor and an external procurement activity that clarifies the operation of the Contract for the external procurement activity concerned. The terms and conditions in any participating addendum shall affect only the procurements of the purchasing entities under the jurisdiction of the external procurement activity signing the participating addendum.
- 3) *Public procurement unit:* The term, as defined in 62 Pa. C. S. Section 1901, means a 'local public procurement unit or purchasing agency.'
- 4) *Purchasing agency:* The term, as defined in 62 Pa. C. S. Section 103, means a 'Commonwealth agency authorized by this part or any other law to enter into contracts for itself or as the agent of another Commonwealth agency.'

b. **General.** A participating addendum shall incorporate the terms and conditions of the Contract resulting from this IFB. The Contractor shall not be required to enter into any participating addendum.

c. **Additional Terms.**

- 1) A participating addendum may include additional terms that are required by the law governing the external procurement activity.
- 2) A participating addendum may include new, mutually agreed upon terms that clarify ordering procedures specific to a participating external procurement activity.
- 3) The construction and effect of any participating addendum shall be governed by and construed in accordance with the laws governing the external procurement activity.
- 4) If an additional term requested by the external procurement activity will result in an increased cost to the Contractor, the Contractor shall adjust its pricing up or down accordingly.

d. **Prices.**

- 1) **Price adjustment** For any costs affecting the percent markup that the Contractor will or will not incur or

that differ from costs incurred or not incurred in the fulfillment of this Contract, the Contractor shall adjust its pricing up or down accordingly. These costs may include, but not be limited to:

- a) State and local taxes;
  - b) Unemployment and workers compensation fees;
  - c) E-commerce transaction fees; and
  - d) Costs associated with additional terms, established pursuant to the Contract.
- 2) The Contractor's pricing for an external procurement activity shall be firm and fixed for the duration of the initial term of the Contract. After the initial term of the Contract, if the Contract is renewed, the Contractor's pricing may be adjusted up or down based on market conditions only with the mutual agreement of both the Contractor and any external procurement activity.

**e. Usage Reports on External Procurement Activities.**

The Contractor shall furnish to the Contracting Officer an electronic quarterly usage report, preferably in spreadsheet format no later than the fifteenth calendar day of the succeeding calendar quarter. Reports shall be e-mailed to the Contracting Officer for the Contract. Each report shall indicate the name and address of the Contractor, contract number, period covered by the report, the name of the external procurement activity that has used the Contract and the total volume of sales to the external procurement activity for the reporting period.

- f. Electronic Copy of Participating Addendum.** The Contractor, upon request of the Contracting Officer, shall submit **one** electronic copy of the participating addendum to the Contracting Officer within **ten** days after request.

**I.11 IFB-029.1 Prices (Dec 6 2006)**

The bid submitted by the successful Bidder will be incorporated into any resulting Contract and the Bidder will be required to provide the awarded item(s) at the prices quoted in its Bid.

**I.12 IFB-030.1 Approved Equal (Nov 2006)**

Whenever an item is defined in this IFB by trade name and catalogue number of a manufacturer or vendor, the term 'or approved equal,' if not inserted therewith shall be implied. Any reference to a particular manufacturer's product either by trade name or by limited description is solely for the purpose of more clearly indicating the minimum standard of quality desired, except where a 'no substitute' is requested. When a 'no substitute' is requested, the Issuing Office will consider Bids for the referenced product only. The term 'or approved equal' is defined as meaning any other make which, in the sole opinion of the Issuing Office, is of such character, quality, and performance equivalence as to meet the standard of quality of products specified for which it is to be used equally as well as that specified. A Bidder quoting on a product other than the referenced product shall: a) furnish complete identification in its Bid of the product it is offering by trade name, brand and/or model number; b) furnish descriptive literature and data with respect to the substitute product it proposes to furnish; and c) indicate any known specification deviations from the referenced product.

**I.13 IFB-031.1 Alternates (Oct 2013)**

A Bidder who wants to offer an alternate must notify the Issuing Office in writing, at least five (5) days prior to the scheduled Bid opening, that the Bidder intends to offer an alternate in its Bid. An "alternate" is a product that deviates from the requirements of the specifications in its composition, qualities, performance, size dimension, etc. The written notification from the Bidder must include a complete description of the alternate and must identify the

product's deviations from the specifications. Upon receipt of the notification, the Issuing Office will determine whether the alternate is acceptable. If the Issuing Office, in its discretion, determines that the alternate is acceptable, the Issuing Office will issue a change notice to the invitation for bids that revises the specifications. If no change notice is issued revising the specification, a Bid offering the alternate will not be considered for award. If an item or items in the IFB are designated "no substitute," this provision does not apply and no alternate may be proposed by a bidder nor will any alternate be considered by the Issuing Office.

#### **I.14 IFB-032.1 New Equipment (Nov 2006)**

Unless otherwise specified in this invitation for bids, all products offered by Bidders must be new or remanufactured. A 'new' product is one that will be used first by the Commonwealth after it is manufactured or produced. A 'remanufactured' product is one which: 1) has been rebuilt, using new or used parts, to a condition which meets the original manufacturer's most recent specifications for the item; 2) does not, in the opinion of the Issuing Office, differ in appearance from a new item; and 3) has the same warranty as a new item. Unless otherwise specified in this invitation for bids, used or reconditioned products are not acceptable. This clause shall not be construed to prohibit Bidders from offering products with recycled content, provided the product is new or remanufactured.

#### **I.15 I-IFB-033.1 Modification or Withdrawal of Bid (Nov 2006)**

- a. Bid Modification Prior to Bid Opening. Bids may be modified only by written notice or in person prior to the exact hour and date specified for Bid opening.
  - 1) If a Bidder intends to modify its Bid by written notice, the notice must specifically identify the Bid to be modified and must be signed by the Bidder. The Bidder must include evidence of authorization for the individual who signed the modification to modify the Bid on behalf of the Bidder. The Bid modification must be received in a sealed envelope. The sealed envelope must identify the assigned Collective Number and the Bid Opening Time, and should state that enclosed in the envelope is a Bid modification
  - 2) If a Bidder intends to modify its Bid in person, the individual who will modify the Bid must arrive in the Bid Opening Room prior to the Bid Opening Time, show a picture identification and provide evidence of his/her authorization to modify the Bid on behalf of the Bidder. If a Bidder intends to modify its Bid in person, the Bidder may do so only in the presence of an agency employee. (The agency employee will observe the actions taken by the individual to modify the Bid, but will not read the Bid or the modification).
- b. Bid Withdrawal Prior to Bid Opening. Bids may be withdrawn only by written notice or in person prior to the exact hour and date specified for Bid opening.
  - 1) If a Bidder intends to withdraw its Bid by written notice, the notice shall specifically identify the Bid to be withdrawn and shall be signed by the Bidder. The Bidder must include evidence of authorization for the individual who signed the bid withdrawal to withdraw the bid on behalf of the Bidder. Except as provided in Subparagraph c, below, bid withdrawals received after the exact hour and date specified for the receipt of Bids shall not be accepted.
  - 2) If a Bidder intends to withdraw its Bid in person, the individual who will withdraw the Bid must arrive in the Bid Opening Room prior to the Bid Opening Time, show a picture identification and provide evidence of his/her authorization to withdraw the Bid on behalf of the Bidder.
- c. Bid Withdrawal After Bid Opening. Bidders are permitted to withdraw erroneous Bids after Bid opening only if the following conditions are met:
  - 1) The Bidder submits a written request for withdrawal.
  - 2) The Bidder presents credible evidence with the request that the reason for the lower Bid price was a clerical mistake as opposed to a judgment mistake and was actually due to an unintentional arithmetical error or an unintentional omission of a substantial quantity of work, labor, material, or services made directly in the compilation of the Bid.

- 3) The request for relief and supporting evidence must be received by the Issuing Office within three (3) business days after Bid opening, but before award of the contract.
  - 4) The Issuing Office shall not permit a Bid withdrawal if the Bid withdrawal would result in the award of the contract on another Bid of the same Bidder, its partner, or a corporation or business venture owned by or in which the bidder has a substantial interest.
  - 5) If a Bidder is permitted to withdraw its Bid, the Bidder cannot supply any material or labor or perform any subcontract or other work agreement for the awarded contractor, without the written approval of the Issuing Office.
- d. **Firm Bid.** Except as provided above, a Bid may not be modified, withdrawn, or cancelled by any Bidder for a period of sixty (60) days following the time and date designated for Bid opening, unless otherwise specified by the Bidder in its Bid. If the lowest responsible Bidder, as determined by the Issuing Office, withdraws its Bid prior to the expiration of the award period or fails to comply with the requirements set forth in the IFB including but not limited to any requirement to submit performance or payment bonds or insurance certificates within the required time period, the Bidder shall be liable to the Commonwealth for all costs and damages associated with the re-award or re-bid including the difference between the Bidder's price and the actual cost that the Commonwealth pays for the awarded items.
- e. **Clarification and Additional Information.** After the receipt of Bids, the Issuing Office shall have the right to contact Bidders for the purpose of seeking:
- 1) Clarification of the Bid which confirms the Issuing Office's understanding of statements or information in the Bid or;
  - 2) Additional information on the items offered; provided the IFB does not require the rejection of the Bid for failure to include such information.

#### **I.16 I-IFB-034.1 Rejection of Bids (Nov 2006)**

The Issuing Office reserves the right to reject any and all Bids, to waive technical defects or any informality in Bids, and to accept or reject any part of any Bid if the best interests of the Commonwealth are thereby served.

#### **I.17 Submission-001.1 Representations and Authorizations (February 2017)**

By submitting its proposal, each Offeror understands, represents, and acknowledges that:

- A. All of the Offeror's information and representations in the proposal are material and important, and the Issuing Office may rely upon the contents of the proposal in awarding the contract(s). The Commonwealth shall treat any misstatement, omission or misrepresentation as fraudulent concealment of the true facts relating to the Proposal submission, punishable pursuant to 18 Pa. C.S. § 4904.
- B. The Offeror has arrived at the price(s) and amounts in its proposal independently and without consultation, communication, or agreement with any other Offeror or potential offeror.
- C. The Offeror has not disclosed the price(s), the amount of the proposal, nor the approximate price(s) or amount(s) of its proposal to any other firm or person who is an Offeror or potential offeror for this RFP, and the Offeror shall not disclose any of these items on or before the proposal submission deadline specified in the Calendar of Events of this RFP.
- D. The Offeror has not attempted, nor will it attempt, to induce any firm or person to refrain from submitting a proposal on this contract, or to submit a proposal higher than this proposal, or to submit any intentionally high or noncompetitive proposal or other form of complementary proposal.



E. The Offeror makes its proposal in good faith and not pursuant to any agreement or discussion with, or inducement from, any firm or person to submit a complementary or other noncompetitive proposal.

F. To the best knowledge of the person signing the proposal for the Offeror, the Offeror, its affiliates, subsidiaries, officers, directors, and employees are not currently under investigation by any governmental agency and have not in the last four years been convicted or found liable for any act prohibited by State or Federal law in any jurisdiction, involving conspiracy or collusion with respect to bidding or proposing on any public contract, except as the Offeror has disclosed in its proposal.

G. To the best of the knowledge of the person signing the proposal for the Offeror and except as the Offeror has otherwise disclosed in its proposal, the Offeror has no outstanding, delinquent obligations to the Commonwealth including, but not limited to, any state tax liability not being contested on appeal or other obligation of the Offeror that is owed to the Commonwealth.

H. The Offeror is not currently under suspension or debarment by the Commonwealth, any other state or the federal government, and if the Offeror cannot so certify, then it shall submit along with its proposal a written explanation of why it cannot make such certification.

I. The Offeror has not made, under separate contract with the Issuing Office, any recommendations to the Issuing Office concerning the need for the services described in its proposal or the specifications for the services described in the proposal.

J. Each Offeror, by submitting its proposal, authorizes Commonwealth agencies to release to the Commonwealth information concerning the Offeror's Pennsylvania taxes, unemployment compensation and workers' compensation liabilities.

K. Until the selected Offeror receives a fully executed and approved written contract from the Issuing Office, there is no legal and valid contract, in law or in equity, and the Offeror shall not begin to perform.

L. The Offeror is not currently engaged, and will not during the duration of the contract engage, in a boycott of a person or an entity based in or doing business with a jurisdiction which the Commonwealth is not prohibited by Congressional statute from engaging in trade or commerce.

## **PART II - REQUIREMENTS**

### **PART II - REQUIREMENTS**

#### **II.1 IFB-006.1b COSTARS Program Election to Participate (July 2012)**

If the bidder is willing to sell the awarded items/services at the same prices and/or discounts, and in accordance with the contractual terms and conditions, to COSTARS members, the bidder should complete and return the COSTARS Program Election to Participate form which is an attachment to this IFB. If the bidder is asserting that it is a Department of General Services Certified Small Business, the bidder must submit its active certification with the bid response.

#### **II.2 II-IFB-008.1b Lobbying Certification and Disclosure – Electronic Submission. (Oct 2006).**

With respect to an award of a federal contract, grant, or cooperative agreement exceeding \$100,000 or an award of a federal loan or a commitment providing for the United States to insure or guarantee a loan exceeding \$150,000 all recipients must certify that they will not use federal funds for lobbying and must disclose the use of non-federal funds for lobbying by filing required documentation. Offerors must complete and return the Lobbying Certification Form and the Disclosure of Lobbying Activities Form, which are attached to and made a part of this IFB. The completed and signed Lobbying Certification Form and the Disclosure of Lobbying Activities Form should be submitted with the Bid Response. Commonwealth agencies will not contract with outside firms or individuals to perform lobbying services, regardless of the source of funds.

#### **II.3 IFB-010.1 License Required (Oct 2013)**

It is unlawful for any individual, corporation, partnership, association or other entity foreign or domestic to engage in the business of salesperson, broker, dealer, manufacturer, factory branch, distributor, distributor branch, factory or distributor representative or wholesaler within COMMONWEALTH unless he has secured a license as required by Act No. 84 of 1983, known as the Board of Vehicles Act. Before a Contract is awarded to any bidder and before a bidder sells COMMONWEALTH any vehicle covered by this requisition, he must hold or secure an appropriate license issued by the State Board of Vehicle Manufacturers, Dealers and Salespersons. Information and/or an application in regard to the license requirement can be obtained from:

Department of State  
Bureau of Professional and Occupational Affairs  
State Board of Motor Vehicle Manufacturers, Dealers and Salesmen  
P.O. Box 2649  
Harrisburg, PA 17105-2649

Out-Of-State Dealers are not required to secure a license under Act No. 84 of 1983, and therefore, do not need to comply with this "License Required" Section. If you are a PA Dealer, please submit your license number with your bid.

#### **II.4 IFB-011.1 Authorized Dealer/Franchiser (Oct 2006)**

In order to be eligible for award, an offeror must be an Authorized/Franchised dealer representing the manufacturer of Vehicles offered to the Commonwealth.

#### **II.5 II-IFB-016.1 Post-Submission Descriptive Literature (Dec 2006)**

The Commonwealth may, during its evaluation of the bids, require any bidder to submit cuts, illustrations, drawings, prints, test data sheets, specification sheets and brochures which detail construction features, design, components, materials used, applicable dimensions and any other pertinent information which the Issuing Office may require in order to evaluate the product(s) offered. The required information must be submitted within two (2) business days after notification from the Issuing Office. Failure to submit the required information prior to the expiration of the second business day after notification shall result in the rejection of the bid as non-responsive.

**II.6 II-IFB-017.1b Reciprocal Limitations Act – Electronic Submittal (February 2007)**

This procurement is subject to the Reciprocal Limitations Act. Bidders must complete and submit with the Bid Response the State of Manufacture Chart, which is contained in GSPUR-89 ("Reciprocal Limitations Act Requirements") which is attached to and made part of this IFB. The completed State of Manufacture Chart should be submitted as part of the Bid Reponse

**II.7 II-IFB-018.1b Iran Free Procurement Certification and Disclosure – Electronic Submittal (November 2016)**

Prior to entering a contract worth at least \$1,000,000 or more with a Commonwealth entity, a bidder must: a) certify it is not on the current list of persons engaged in investment activities in Iran created by the Pennsylvania Department of General Services ("DGS") pursuant to Section 3503 of the Procurement Code and is eligible to contract with the Commonwealth under Sections 3501-3506 of the Procurement Code; or b) demonstrate it has received an exception from the certification requirement for that solicitation or contract pursuant to Section 3503(e). All bidders must complete and return the Iran Free Procurement Certification form, which is attached hereto and made part of this IFB. The completed and signed Iran Free Procurement Certification form must be submitted with the Bid Response.

See the following web page for current Iran Free Procurement list:

<http://www.dgs.pa.gov/businesses/materials%20and%20services%20procurement/procurement-resources/pages/default.aspx#.WDNfJJ>

## **PART III - SELECTION CRITERIA**

### **PART III - SELECTION CRITERIA**

#### **III.1 III-IFB-001.1a Mandatory Responsiveness Requirements (Oct 2006)**

To be eligible for selection, a bid must be:

- a. Timely received from a Bidder;
- b. Properly signed by the Bidder.

#### **III.2 III-IFB-006.1f Method of Award - All Bidders (April 2011)**

Award will be made to all responsive and responsible bidders.

#### **III.3 III-IFB-007.1 Awards (May 2011)**

Unless all Bids are rejected, and except as otherwise provided by law, award will be made through the issuance of a contract/purchase order in accordance with the method of award. Unless otherwise specified by the Issuing Office in the IFB form the Commonwealth reserves the right to award by item or on a total Bid basis, whichever is deemed more advantageous to the Commonwealth. In cases of discrepancies in prices, the unit price will be binding unless the unit price is obviously in error and the extended price is obviously correct, in which case the erroneous unit price will be corrected. As a condition for receipt of award of a contract/purchase order, the Bidder must be registered in the Commonwealth of Pennsylvania's Vendor Master file. In order to register, bidders must visit the Pa Supplier Portal at <https://www.pasupplierportal.state.pa.us/> or call the Customer Support Center at 877-435-7363 or 717-346-2676.

#### **III.4 III-IFB-008.1 Tie Bids (Nov 2006)**

All tie bids will be broken by the Issuing Office.

#### **III.5 III-IFB-009.1 Prompt Payment Discounts (Nov 2006)**

Prompt payment discounts will not be considered in making an award. If prompt payment discounts are offered by any Bidder, however, the Issuing Office will take advantage of such offer.

#### **III.6 III-IFB-010.1 Option for Separate Competitive Bidding Procedure (Nov 2006)**

The Commonwealth reserves the right to purchase products or services covered under this Contract through a separate competitive bidding procedure, whenever Commonwealth deems it in the best interest of the Commonwealth. The right will generally be exercised only when a specific need for a large quantity of the product or service exists or when the price offered is significantly lower than the Contract price.

#### **III.7 III-IFB-014.1 Rebates (Nov 2006)**

Any rebate applicable at the time of bid should be taken into consideration by the bidder in calculating its bid price. Bidders must specifically state in their bid proposal, when applicable, that rebates have been considered in arriving at the bid price. Following award, the Commonwealth will assign to the awarded bidder, any rebates which the bidder stated that he took into consideration. If the bidder fails to include such a statement, the Commonwealth will receive the full benefit of the manufacturer's rebate.



**PART IV - WORK STATEMENT**

**PART IV - WORK STATEMENT**

**IV.1 IFB-001.1a Specifications (Nov 2006)**

The Commonwealth is seeking bids to procure the item(s) set forth in the attached document entitled "Specifications."

## **PART V - CONTRACT TERMS and CONDITIONS**

### **PART V - CONTRACT TERMS and CONDITIONS**

#### **V.1 CONTRACT-001.1b Contract Terms and Conditions (Nov 30, 2006)**

The Contract with the awarded bidder (who shall become the "Contractor") shall include the following terms and conditions:

#### **V.2 CONTRACT-002.1a Term of Contract – Contract (May 2012)**

The initial term of the Contract shall be 01 year(s) and 00 month(s).

The term of the Contract shall commence on the Effective Date (as defined below) and shall end on the Expiration Date identified in the Contract, subject to the other provisions of the Contract.

The Effective Date shall be: a) the Effective Date printed on the Contract after the Contract has been fully executed by the Commonwealth (signed and approved as required by the Commonwealth contracting procedures) or b) the "Valid from" date printed on the Contract, whichever is later.

#### **V.3 CONTRACT-002.2b Renewal of Contract Term – Mutual (Oct 2013)**

The Contract may be mutually renewed for a maximum of 4 additional 1 year term(s), so long as the Commonwealth provides written notice to Contractor of its intention to extend the Contract by letter dated not less than 090 days prior to the expiration of the term of the agreement, or any extension thereof, and the Contractor consents to the renewal not less than 060 days prior to the expiration of the term of the agreement or any extension thereof. The renewal may be exercised as individual or multiple year terms(s). Any renewal will be under the same terms, covenants and conditions. No further document is required to be executed to renew the term of the contract.

#### **V.4 CONTRACT-002.3 Extension of Contract Term (Nov 30 2006)**

The Commonwealth reserves the right, upon notice to the Contractor, to extend any single term of the Contract for up to three (3) months upon the same terms and conditions.

#### **V.5 CONTRACT-003.1a Signatures – Contract (July 2015)**

The Contract shall not be a legally binding contract until the fully-executed Contract has been sent to the Contractor. No Commonwealth employee has the authority to verbally direct the commencement of any work or delivery of any supply under this Contract prior to the Effective Date. The Contractor hereby waives any claim or cause of action for any service or work performed prior to the Effective Date.

The Contract may be electronically signed by the Commonwealth. The electronically-printed name of the Purchasing Agent represents the signature of that individual who has the authority, on behalf of the Commonwealth, to bind the Commonwealth to the terms of the Contract. If the Contract output form does not have "Fully Executed" at the top of the first page and does not have the name of the Purchasing Agent printed in the appropriate box, the Contract has not been fully executed.

The fully-executed Contract may be sent to the Contractor electronically or through facsimile equipment. The electronic transmission of the Contract shall require acknowledgement of receipt of the transmission by the Contractor. Receipt of the electronic or facsimile transmission of the Contract shall constitute receipt of the fully-executed Contract.

The Commonwealth and the Contractor specifically agree as follows:

- a. No handwritten signature shall be required in order for the Contract to be legally enforceable.
- b. The parties agree that no writing shall be required in order to make the Contract legally binding, notwithstanding

contrary requirements in any law. The parties hereby agree not to contest the validity or enforceability of a genuine Contract or acknowledgement issued electronically under the provisions of a statute of frauds or any other applicable law relating to whether certain agreements be in writing and signed by the party bound thereby. Any genuine Contract or acknowledgement issued electronically, if introduced as evidence on paper in any judicial, arbitration, mediation, or administrative proceedings, will be admissible as between the parties to the same extent and under the same conditions as other business records originated and maintained in documentary form. Neither party shall contest the admissibility of copies of a genuine Contract or acknowledgements under either the business records exception to the hearsay rule or the best evidence rule on the basis that the Contract or acknowledgement were not in writing or signed by the parties. A Contract or acknowledgment shall be deemed to be genuine for all purposes if it is transmitted to the location designated for such documents.

c. Each party will immediately take steps to verify any document that appears to be obviously garbled in transmission or improperly formatted to include re-transmission of any such document if necessary.

#### **V.6 CONTRACT-004.1a Definitions (Oct 2013)**

As used in this Contract, these words shall have the following meanings:

a. Agency: The department, board, commission or other agency of the Commonwealth of Pennsylvania listed as the Purchasing Agency. If a COSTARS entity or external procurement activity has issued an order against this contract, that entity shall also be identified as "Agency".

b. Contracting Officer: The person authorized to administer this Contract for the Commonwealth and to make written determinations with respect to the Contract.

c. Days: Unless specifically indicated otherwise, days mean calendar days.

d. Developed Works or Developed Materials: All documents, sketches, drawings, designs, works, papers, files, reports, computer programs, computer documentation, data, records, software, samples or any other tangible material without limitation authored or prepared by Contractor as the work product covered in the scope of work for the Project.

e. Documentation: All materials required to support and convey information about the services required by this Contract. It includes, but is not necessarily restricted to, written reports and analyses, diagrams, maps, logical and physical designs, system designs, computer programs, flow charts, disks, and/or other machine-readable storage media.

f. Services: All Contractor activity necessary to satisfy the Contract.

#### **V.7 CONTRACT-005.1c Purchase Orders - Vehicles (July 2015)**

Commonwealth agencies may issue Purchase Orders against the Contract. These orders constitute the Contractor's authority to make delivery. All Purchase Orders received by the Contractor up to and including the expiration date of the Contract are acceptable and must be performed in accordance with the Contract. Each Purchase Order will be deemed to incorporate the terms and conditions set forth in the Contract.

Purchase Orders may be electronically signed by the Agency. The electronically-printed name of the purchaser represents the signature of that individual who has the authority, on behalf of the Commonwealth, to authorize the Contractor to proceed.

Purchase Orders may be issued electronically or through facsimile equipment. Receipt of the electronic or facsimile transmission of the Purchase Order shall constitute receipt of an order. Orders received by the Contractor after 4:00 p.m. will be considered received the following business day. The Contractor must acknowledge receipt of an order within ten (10) days from the day the purchase order is issued to the Contractor. In order to insure timely delivery, the Commonwealth should follow up on orders if written acknowledgment is not received within ten (10) days.

The Commonwealth and the Contractor specifically agree as follows:

a. No handwritten signature shall be required in order for the Contract or Purchase Order to be legally enforceable.



b. Any order which is issued electronically shall not give rise to any obligation to deliver on the part of the Contractor, or any obligation to receive and pay for delivered products on the part of the Commonwealth, unless and until the Commonwealth Agency transmitting the order has properly received an acknowledgement.

c. The parties agree that no writing shall be required in order to make the Purchase Order legally binding. The parties hereby agree not to contest the validity or enforceability of a Purchase Order or acknowledgement issued electronically under the provisions of a statute of frauds or any other applicable law relating to whether certain agreements be in writing and signed by the party bound thereby. Any Purchase Order or acknowledgement issued electronically, if introduced as evidence on paper in any judicial, arbitration, mediation, or administrative proceedings, will be admissible as between the parties to the same extent and under the same conditions as other business records originated and maintained in documentary form. Neither party shall contest the admissibility of copies of Purchase Orders or acknowledgements under either the business records exception to the hearsay rule or the best evidence rule on the basis that the Purchase Order or acknowledgement were not in writing or signed by the parties. A Purchase Order or acknowledgment shall be deemed to be genuine for all purposes if it is transmitted to the location designated for such documents.

d. Each party will immediately take steps to verify any document that appears to be obviously garbled in transmission or improperly formatted to include re-transmission of any such document if necessary.

#### **V.8 CONTRACT-006.1 Independent Prime Contractor (Oct 2006)**

In performing its obligations under the Contract, the Contractor will act as an independent contractor and not as an employee or agent of the Commonwealth. The Contractor will be responsible for all services in this Contract whether or not Contractor provides them directly. Further, the Contractor is the sole point of contact with regard to all contractual matters, including payment of any and all charges resulting from the Contract.

#### **V.9 CONTRACT-007.01c Delivery – Vehicles (Oct 2013)**

All vehicle(s) shall be delivered F.O.B. Destination. The Contractor agrees to bear the risk of loss, injury, or destruction of the vehicle(s) ordered prior to the receipt of the vehicle(s) by the Commonwealth. Such loss, injury, or destruction shall not release the Contractor from any contractual obligations. Except as otherwise provided in this contract, all vehicle(s) must be delivered within the time period specified in the Contract. Time is of the essence and, in addition to any other remedies, the Contract is subject to termination for failure to deliver as specified.

#### **V.10 CONTRACT-007.02 Estimated Quantities (Nov 30 2006)**

It shall be understood and agreed that any quantities listed in the Contract are estimated only and may be increased or decreased in accordance with the actual requirements of the Commonwealth and that the Commonwealth in accepting any bid or portion thereof, contracts only and agrees to purchase only the materials and services in such quantities as represent the actual requirements of the Commonwealth. The Commonwealth reserves the right to purchase materials and services covered under the Contract through a separate competitive procurement procedure, whenever Commonwealth deems it to be in its best interest.

#### **V.11 CONTRACT-008.1a Warranty. (Oct 2006)**

The Contractor warrants that all items furnished and all services performed by the Contractor, its agents and subcontractors shall be free and clear of any defects in workmanship or materials. Unless otherwise stated in the Contract, all items are warranted for a period of one year following delivery by the Contractor and acceptance by the Commonwealth. The Contractor shall repair, replace or otherwise correct any problem with the delivered item. When an item is replaced, it shall be replaced with an item of equivalent or superior quality without any additional cost to the Commonwealth.

#### **V.12 CONTRACT-009.1c Patent, Copyright, and Trademark Indemnity (Oct 2013)**

The Contractor warrants that it is the sole owner or author of, or has entered into a suitable legal agreement

concerning either: a) the design of any product or process provided or used in the performance of the Contract which is covered by a patent, copyright, or trademark registration or other right duly authorized by state or federal law or b) any copyrighted matter in any report, document or other material provided to the Commonwealth under the contract.

The Contractor shall defend any suit or proceeding brought against the Commonwealth on account of any alleged patent, copyright or trademark infringement in the United States of any of the products provided or used in the performance of the Contract.

This is upon condition that the Commonwealth shall provide prompt notification in writing of such suit or proceeding; full right, authorization and opportunity to conduct the defense thereof; and full information and all reasonable cooperation for the defense of same.

As principles of governmental or public law are involved, the Commonwealth may participate in or choose to conduct, in its sole discretion, the defense of any such action.

If information and assistance are furnished by the Commonwealth at the Contractor's written request, it shall be at the Contractor's expense, but the responsibility for such expense shall be only that within the Contractor's written authorization.

The Contractor shall indemnify and hold the Commonwealth harmless from all damages, costs, and expenses, including attorney's fees that the Contractor or the Commonwealth may pay or incur by reason of any infringement or violation of the rights occurring to any holder of copyright, trademark, or patent interests and rights in any products provided or used in the performance of the Contract.

If any of the products provided by the Contractor in such suit or proceeding are held to constitute infringement and the use is enjoined, the Contractor shall, at its own expense and at its option, either procure the right to continue use of such infringement products, replace them with non-infringement equal performance products or modify them so that they are no longer infringing.

If the Contractor is unable to do any of the preceding, the Contractor agrees to remove all the equipment or software which are obtained contemporaneously with the infringing product, or, at the option of the Commonwealth, only those items of equipment or software which are held to be infringing, and to pay the Commonwealth: 1) any amounts paid by the Commonwealth towards the purchase of the product, less straight line depreciation; 2) any license fee paid by the Commonwealth for the use of any software, less an amount for the period of usage; and 3) the pro rata portion of any maintenance fee representing the time remaining in any period of maintenance paid for. The obligations of the Contractor under this paragraph continue without time limit. No costs or expenses shall be incurred for the account of the Contractor without its written consent.

#### **V.13 CONTRACT-009.1d Ownership Rights (Oct 2006)**

The Commonwealth shall have unrestricted authority to reproduce, distribute, and use any submitted report, data, or material, and any software or modifications and any associated documentation that is designed or developed and delivered to the Commonwealth as part of the performance of the Contract.

#### **V.14 CONTRACT-010.1a Acceptance (Oct 2006)**

No item(s) received by the Commonwealth shall be deemed accepted until the Commonwealth has had a reasonable opportunity to inspect the item(s). Any item(s) which is discovered to be defective or fails to conform to the specifications may be rejected upon initial inspection or at any later time if the defects contained in the item(s) or the noncompliance with the specifications were not reasonably ascertainable upon the initial inspection. It shall thereupon become the duty of the Contractor to remove rejected item(s) from the premises without expense to the Commonwealth within fifteen (15) days after notification. Rejected item(s) left longer than fifteen (15) days will be regarded as abandoned, and the Commonwealth shall have the right to dispose of them as its own property and shall retain that portion of the proceeds of any sale which represents the Commonwealth's costs and expenses in regard to the storage and sale of the item(s). Upon notice of rejection, the Contractor shall immediately replace all such rejected item(s) with others conforming to the specifications and which are not defective. If the Contractor fails,

neglects or refuses to do so, the Commonwealth shall then have the right to procure a corresponding quantity of such item(s), and deduct from any monies due or that may thereafter become due to the Contractor, the difference between the price stated in the Contract and the cost thereof to the Commonwealth.

#### **V.15 CONTRACT-010.2 Product Conformance (March 2012)**

The Commonwealth reserves the right to require any and all Contractors to:

1. Provide certified data from laboratory testing performed by the Contractor, or performed by an independent laboratory, as specified by the Commonwealth.
2. Supply published manufacturer product documentation.
3. Permit a Commonwealth representative to witness testing at the Contractor's location or at an independent laboratory.
4. Complete a survey/questionnaire relating to the bid requirements and specifications.
5. Provide customer references.
6. Provide a product demonstration at a location near Harrisburg or the using agency location.

#### **V.16 CONTRACT-010.3 Rejected Material Not Considered Abandoned (March 2012)**

The Commonwealth shall have the right to not regard any rejected material as abandoned and to demand that the Contractor remove the rejected material from the premises within thirty (30) days of notification. The Contractor shall be responsible for removal of the rejected material as well as proper clean-up. If the Contractor fails or refuses to remove the rejected material as demanded by the Commonwealth, the Commonwealth may seek payment from, or set-off from any payments due to the Contractor under this or any other Contract with the Commonwealth, the costs of removal and clean-up. This is in addition to all other rights to recover costs incurred by the Commonwealth.

#### **V.17 CONTRACT-011.1a Compliance With Law (Oct 2006)**

The Contractor shall comply with all applicable federal and state laws and regulations and local ordinances in the performance of the Contract.

#### **V.18 CONTRACT-013.1 Environmental Provisions (Oct 2006)**

In the performance of the Contract, the Contractor shall minimize pollution and shall strictly comply with all applicable environmental laws and regulations, including, but not limited to: the Clean Streams Law Act of June 22, 1937 (P.L. 1987, No. 394), as amended 35 P.S. Section 691.601 et seq.; the Pennsylvania Solid Waste Management Act, Act of July 7, 1980 (P.L. 380, No. 97), as amended, 35 P.S. Section 6018.101 et seq. ; and the Dam Safety and Encroachment Act, Act of November 26, 1978 (P.L. 1375, No. 325), as amended , 32 P.S. Section 693.1.

#### **V.19 CONTRACT-014.1 Post-Consumer Recycled Content (June 2016)**

Except as specifically waived by the Department of General Services in writing, any products which are provided to the Commonwealth as a part of the performance of the Contract must meet the minimum percentage levels for total recycled content as specified by the Environmental Protection Agency in its Comprehensive Procurement Guidelines, which can be found at <https://www.epa.gov/smm/comprehensive-procurement-guideline-cpg-program> .

### **V.20 CONTRACT-014.3 Recycled Content Enforcement (February 2012)**

The Contractor may be required, after delivery of the Contract item(s), to provide the Commonwealth with documentary evidence that the item(s) was in fact produced with the required minimum percentage of post-consumer and recovered material content.

### **V.21 CONTRACT-015.1 Compensation (Oct 2006)**

The Contractor shall be required to furnish the awarded item(s) at the price(s) quoted in the Purchase Order. All item(s) shall be delivered within the time period(s) specified in the Purchase Order. The Contractor shall be compensated only for item(s) that are delivered and accepted by the Commonwealth.

### **V.22 CONTRACT-015.2 Billing Requirements (July 2021)**

Unless the Contractor has been authorized by the Commonwealth for Evaluated Receipt Settlement or Vendor Self-Invoicing, the Contractor shall include in all of its invoices the following minimum information:

- Vendor name and "Remit to" address, including SAP Vendor number;
- SAP Purchase Order number;
- Delivery Address, including name of Commonwealth agency;
- Description of the supplies/services delivered in accordance with SAP Purchase Order (include purchase order line number if possible);
- Quantity provided;
- Unit price;
- Price extension;
- Total price; and
- Delivery date of supplies or services.

If an invoice does not contain the minimum information set forth in this paragraph, the Commonwealth may return the invoice as improper. If the Commonwealth returns an invoice as improper, the time for processing a payment will be suspended until the Commonwealth receives a correct invoice. The Contractor may not receive payment until the Commonwealth has received a correct invoice.

Contractors are required to establish separate billing accounts with each using agency and invoice them directly. Each invoice shall be itemized with adequate detail and match the line item on the Purchase Order. In no instance shall any payment be made for services to the Contractor that are not in accordance with the prices on the Purchase Order, the Contract, updated price lists or any discounts negotiated by the purchasing agency.

### **V.23 CONTRACT-016.1 Payment (Oct 2006)**

- a. The Commonwealth shall put forth reasonable efforts to make payment by the required payment date. The required payment date is: (a) the date on which payment is due under the terms of the Contract; (b) thirty (30) days after a proper invoice actually is received at the "Bill To" address if a date on which payment is due is not specified in the Contract (a "proper" invoice is not received until the Commonwealth accepts the service as satisfactorily performed); or (c) the payment date specified on the invoice if later than the dates established by (a) and (b) above. Payment may be delayed if the payment amount on an invoice is not based upon the price(s) as stated in the Contract. If any payment is not made within fifteen (15) days after the required payment date, the Commonwealth may pay interest as determined by the Secretary of Budget in accordance with Act No. 266 of 1982 and regulations promulgated pursuant thereto. Payment should not be construed by the Contractor as acceptance of the service performed by the Contractor. The Commonwealth reserves the right to conduct further testing and inspection after payment, but within a reasonable time after performance, and to reject the service if such post payment testing or inspection discloses a defect or a failure to meet specifications. The Contractor agrees that the Commonwealth may set off the amount of any state tax liability or other obligation of the Contractor or its subsidiaries to the Commonwealth against any payments due the Contractor under any contract

with the Commonwealth.

- b. The Commonwealth shall have the option of using the Commonwealth purchasing card to make purchases under the Contract or Purchase Order. The Commonwealth's purchasing card is similar to a credit card in that there will be a small fee which the Contractor will be required to pay and the Contractor will receive payment directly from the card issuer rather than the Commonwealth. Any and all fees related to this type of payment are the responsibility of the Contractor. In no case will the Commonwealth allow increases in prices to offset credit card fees paid by the Contractor or any other charges incurred by the Contractor, unless specifically stated in the terms of the Contract or Purchase Order.

#### **V.24 CONTRACT-016.2 Payment – Electronic Funds Transfer (July 2022)**

- a. The Commonwealth will make contract payments through Automated Clearing House (ACH). Within 10 days of award of the contract or purchase order, the contractor must submit or must have already submitted their ACH information within their user profile in the Commonwealth's procurement system (SRM).
- b. The contractor must submit a unique invoice number with each invoice submitted. The unique invoice number will be listed on the Commonwealth of Pennsylvania's ACH remittance advice to enable the contractor to properly apply the state agency's payment to the invoice submitted.
- c. It is the responsibility of the contractor to ensure that the ACH information contained in SRM is accurate and complete. Failure to maintain accurate and complete information may result in delays in payments.

#### **V.25 CONTRACT-017.1 Taxes (Dec 5 2006)**

The Commonwealth is exempt from all excise taxes imposed by the Internal Revenue Service and has accordingly registered with the Internal Revenue Service to make tax free purchases under Registration No. 23-23740001-K. With the exception of purchases of the following items, no exemption certificates are required and none will be issued: undyed diesel fuel, tires, trucks, gas guzzler emergency vehicles, and sports fishing equipment. The Commonwealth is also exempt from Pennsylvania state sales tax, local sales tax, public transportation assistance taxes and fees and vehicle rental tax. The Department of Revenue regulations provide that exemption certificates are not required for sales made to governmental entities and none will be issued. Nothing in this paragraph is meant to exempt a construction contractor from the payment of any of these taxes or fees which are required to be paid with respect to the purchase, use, rental, or lease of tangible personal property or taxable services used or transferred in connection with the performance of a construction contract.

#### **V.26 CONTRACT-018.1 Assignment of Antitrust Claims (Oct 2006)**

The Contractor and the Commonwealth recognize that in actual economic practice, overcharges by the Contractor's suppliers resulting from violations of state or federal antitrust laws are in fact borne by the Commonwealth. As part of the consideration for the award of the Contract, and intending to be legally bound, the Contractor assigns to the Commonwealth all right, title and interest in and to any claims the Contractor now has, or may acquire, under state or federal antitrust laws relating to the products and services which are the subject of this Contract.

#### **V.27 CONTRACT-019.1 Hold Harmless Provision (Nov 30 2006)**

- a. The Contractor shall hold the Commonwealth harmless from and indemnify the Commonwealth against any and all third party claims, demands and actions based upon or arising out of any activities performed by the Contractor and its employees and agents under this Contract, provided the Commonwealth gives Contractor prompt notice of any such claim of which it learns. Pursuant to the Commonwealth Attorneys Act (71 P.S. Section 732-101, et seq.), the Office of Attorney General (OAG) has the sole authority to represent the Commonwealth in actions brought against the Commonwealth. The OAG may, however, in its sole discretion and under such terms as it deems appropriate, delegate its right of defense. If OAG delegates the defense to the Contractor, the Commonwealth will cooperate with all reasonable requests of Contractor made in the defense of

such suits.

- b. Notwithstanding the above, neither party shall enter into any settlement without the other party's written consent, which shall not be unreasonably withheld. The Commonwealth may, in its sole discretion, allow the Contractor to control the defense and any related settlement negotiations.

#### **V.28 CONTRACT-020.1 Audit Provisions (Oct 2006)**

The Commonwealth shall have the right, at reasonable times and at a site designated by the Commonwealth, to audit the books, documents and records of the Contractor to the extent that the books, documents and records relate to costs or pricing data for the Contract. The Contractor agrees to maintain records which will support the prices charged and costs incurred for the Contract. The Contractor shall preserve books, documents, and records that relate to costs or pricing data for the Contract for a period of three (3) years from date of final payment. The Contractor shall give full and free access to all records to the Commonwealth and/or their authorized representatives.

#### **V.29 CONTRACT-021.1 Default (Oct 2013)**

a. The Commonwealth may, subject to the Force Majeure provisions of this Contract, and in addition to its other rights under the Contract, declare the Contractor in default by written notice thereof to the Contractor, and terminate (as provided in the Termination Provisions of this Contract) the whole or any part of this Contract or any Purchase Order for any of the following reasons:

- 1) Failure to begin work within the time specified in the Contract or Purchase Order or as otherwise specified;
- 2) Failure to perform the work with sufficient labor, equipment, or material to ensure the completion of the specified work in accordance with the Contract or Purchase Order terms;
- 3) Unsatisfactory performance of the work;
- 4) Failure to deliver the awarded item(s) within the time specified in the Contract or Purchase Order or as otherwise specified;
- 5) Improper delivery;
- 6) Failure to provide an item(s) which is in conformance with the specifications referenced in the Contract or Purchase Order;
- 7) Delivery of a defective item;
- 8) Failure or refusal to remove material, or remove and replace any work rejected as defective or unsatisfactory;
- 9) Discontinuance of work without approval;
- 10) Failure to resume work, which has been discontinued, within a reasonable time after notice to do so;
- 11) Insolvency or bankruptcy;
- 12) Assignment made for the benefit of creditors;
- 13) Failure or refusal within 10 days after written notice by the Contracting Officer, to make payment or show cause why payment should not be made, of any amounts due for materials furnished, labor supplied or performed, for equipment rentals, or for utility services rendered;
- 14) Failure to protect, to repair, or to make good any damage or injury to property;
- 15) Breach of any provision of the Contract;

16) Failure to comply with representations made in the Contractor's bid/proposal; or

17) Failure to comply with applicable industry standards, customs, and practice.

b. In the event that the Commonwealth terminates this Contract or any Purchase Order in whole or in part as provided in Subparagraph a. above, the Commonwealth may procure, upon such terms and in such manner as it determines, items similar or identical to those so terminated, and the Contractor shall be liable to the Commonwealth for any reasonable excess costs for such similar or identical items included within the terminated part of the Contract or Purchase Order.

c. If the Contract or a Purchase Order is terminated as provided in Subparagraph a. above, the Commonwealth, in addition to any other rights provided in this paragraph, may require the Contractor to transfer title and deliver immediately to the Commonwealth in the manner and to the extent directed by the Contracting Officer, such partially completed items, including, where applicable, reports, working papers and other documentation, as the Contractor has specifically produced or specifically acquired for the performance of such part of the Contract or Purchase Order as has been terminated. Except as provided below, payment for completed work accepted by the Commonwealth shall be at the Contract price. Except as provided below, payment for partially completed items including, where applicable, reports and working papers, delivered to and accepted by the Commonwealth shall be in an amount agreed upon by the Contractor and Contracting Officer. The Commonwealth may withhold from amounts otherwise due the Contractor for such completed or partially completed works, such sum as the Contracting Officer determines to be necessary to protect the Commonwealth against loss.

d. The rights and remedies of the Commonwealth provided in this paragraph shall not be exclusive and are in addition to any other rights and remedies provided by law or under this Contract.

e. The Commonwealth's failure to exercise any rights or remedies provided in this paragraph shall not be construed to be a waiver by the Commonwealth of its rights and remedies in regard to the event of default or any succeeding event of default.

f. Following exhaustion of the Contractor's administrative remedies as set forth in the Contract Controversies Provision of the Contract, the Contractor's exclusive remedy shall be to seek damages in the Board of Claims.

### **V.30 CONTRACT-022.1 Force Majeure (Oct 2006)**

Neither party will incur any liability to the other if its performance of any obligation under this Contract is prevented or delayed by causes beyond its control and without the fault or negligence of either party. Causes beyond a party's control may include, but aren't limited to, acts of God or war, changes in controlling law, regulations, orders or the requirements of any governmental entity, severe weather conditions, civil disorders, natural disasters, fire, epidemics and quarantines, general strikes throughout the trade, and freight embargoes.

The Contractor shall notify the Commonwealth orally within five (5) days and in writing within ten (10) days of the date on which the Contractor becomes aware, or should have reasonably become aware, that such cause would prevent or delay its performance. Such notification shall (i) describe fully such cause(s) and its effect on performance, (ii) state whether performance under the contract is prevented or delayed and (iii) if performance is delayed, state a reasonable estimate of the duration of the delay. The Contractor shall have the burden of proving that such cause(s) delayed or prevented its performance despite its diligent efforts to perform and shall produce such supporting documentation as the Commonwealth may reasonably request. After receipt of such notification, the Commonwealth may elect to cancel the Contract, cancel the Purchase Order, or to extend the time for performance as reasonably necessary to compensate for the Contractor's delay.

In the event of a declared emergency by competent governmental authorities, the Commonwealth by notice to the Contractor, may suspend all or a portion of the Contract or Purchase Order.

### **V.31 CONTRACT-023.1a Termination Provisions (Oct 2013)**

The Commonwealth has the right to terminate this Contract or any Purchase Order for any of the following reasons.

Termination shall be effective upon written notice to the Contractor.

a. **TERMINATION FOR CONVENIENCE:** The Commonwealth shall have the right to terminate the Contract or a Purchase Order for its convenience if the Commonwealth determines termination to be in its best interest. The Contractor shall be paid for work satisfactorily completed prior to the effective date of the termination, but in no event shall the Contractor be entitled to recover loss of profits.

b. **NON-APPROPRIATION:** The Commonwealth's obligation to make payments during any Commonwealth fiscal year succeeding the current fiscal year shall be subject to availability and appropriation of funds. When funds (state and/or federal) are not appropriated or otherwise made available to support continuation of performance in a subsequent fiscal year period, the Commonwealth shall have the right to terminate the Contract or a Purchase Order. The Contractor shall be reimbursed for the reasonable value of any nonrecurring costs incurred but not amortized in the price of the supplies or services delivered under the Contract. Such reimbursement shall not include loss of profit, loss of use of money, or administrative or overhead costs. The reimbursement amount may be paid from any appropriations available for that purpose.

c. **TERMINATION FOR CAUSE:** The Commonwealth shall have the right to terminate the Contract or a Purchase Order for Contractor default under the Default Clause upon written notice to the Contractor. The Commonwealth shall also have the right, upon written notice to the Contractor, to terminate the Contract or a Purchase Order for other cause as specified in the Contract or by law. If it is later determined that the Commonwealth erred in terminating the Contract or a Purchase Order for cause, then, at the Commonwealth's discretion, the Contract or Purchase Order shall be deemed to have been terminated for convenience under the Subparagraph a.

#### **V.32 CONTRACT-024.1 Contract Controversies (Oct 2011)**

a. In the event of a controversy or claim arising from the Contract, the Contractor must, within six months after the cause of action accrues, file a written claim with the contracting officer for a determination. The claim shall state all grounds upon which the Contractor asserts a controversy exists. If the Contractor fails to file a claim or files an untimely claim, the Contractor is deemed to have waived its right to assert a claim in any forum. At the time the claim is filed, or within sixty (60) days thereafter, either party may request mediation through the Commonwealth Office of General Counsel Dispute Resolution Program.

b. If the Contractor or the contracting officer requests mediation and the other party agrees, the contracting officer shall promptly make arrangements for mediation. Mediation shall be scheduled so as to not delay the issuance of the final determination beyond the required 120 days after receipt of the claim if mediation is unsuccessful. If mediation is not agreed to or if resolution is not reached through mediation, the contracting officer shall review timely-filed claims and issue a final determination, in writing, regarding the claim. The final determination shall be issued within 120 days of the receipt of the claim, unless extended by consent of the contracting officer and the Contractor. The contracting officer shall send his/her written determination to the Contractor. If the contracting officer fails to issue a final determination within the 120 days (unless extended by consent of the parties), the claim shall be deemed denied. The contracting officer's determination shall be the final order of the purchasing agency.

c. Within fifteen (15) days of the mailing date of the determination denying a claim or within 135 days of filing a claim if, no extension is agreed to by the parties, whichever occurs first, the Contractor may file a statement of claim with the Commonwealth Board of Claims. Pending a final judicial resolution of a controversy or claim, the Contractor shall proceed diligently with the performance of the Contract in a manner consistent with the determination of the contracting officer and the Commonwealth shall compensate the Contractor pursuant to the terms of the Contract.

#### **V.33 CONTRACT-025.1 Assignability and Subcontracting (Oct 2013)**

a. Subject to the terms and conditions of this paragraph, this Contract shall be binding upon the parties and their respective successors and assigns.



b. The Contractor shall not subcontract with any person or entity to perform all or any part of the work to be performed under this Contract without the prior written consent of the Contracting Officer, which consent may be withheld at the sole and absolute discretion of the Contracting Officer.

c. The Contractor may not assign, in whole or in part, this Contract or its rights, duties, obligations, or responsibilities hereunder without the prior written consent of the Contracting Officer, which consent may be withheld at the sole and absolute discretion of the Contracting Officer.

d. Notwithstanding the foregoing, the Contractor may, without the consent of the Contracting Officer, assign its rights to payment to be received under the Contract, provided that the Contractor provides written notice of such assignment to the Contracting Officer together with a written acknowledgement from the assignee that any such payments are subject to all of the terms and conditions of this Contract.

e. For the purposes of this Contract, the term "assign" shall include, but shall not be limited to, the sale, gift, assignment, pledge, or other transfer of any ownership interest in the Contractor provided, however, that the term shall not apply to the sale or other transfer of stock of a publicly traded company.

f. Any assignment consented to by the Contracting Officer shall be evidenced by a written assignment agreement executed by the Contractor and its assignee in which the assignee agrees to be legally bound by all of the terms and conditions of the Contract and to assume the duties, obligations, and responsibilities being assigned.

g. A change of name by the Contractor, following which the Contractor's federal identification number remains unchanged, shall not be considered to be an assignment hereunder. The Contractor shall give the Contracting Officer written notice of any such change of name.

#### **V.34 CONTRACT-026.1 Other Contractors (Oct 2006)**

The Commonwealth may undertake or award other contracts for additional or related work, and the Contractor shall fully cooperate with other contractors and Commonwealth employees, and coordinate its work with such additional work as may be required. The Contractor shall not commit or permit any act that will interfere with the performance of work by any other contractor or by Commonwealth employees. This paragraph shall be included in the Contracts of all contractors with which this Contractor will be required to cooperate. The Commonwealth shall equitably enforce this paragraph as to all contractors to prevent the imposition of unreasonable burdens on any contractor.

#### **V.35 CONTRACT-027.1 Nondiscrimination/Sexual Harassment Clause (August 2018)**

The Contractor agrees:

1. In the hiring of any employee(s) for the manufacture of supplies, performance of work, or any other activity required under the contract or any subcontract, the Contractor, each subcontractor, or any person acting on behalf of the Contractor or subcontractor shall not discriminate by reason of race, gender, creed, color, sexual orientation, gender identity or expression, or in violation of the *Pennsylvania Human Relations Act* (PHRA) and applicable federal laws, against any citizen of this Commonwealth who is qualified and available to perform the work to which the employment relates.

2. Neither the Contractor nor any subcontractor nor any person on their behalf shall in any manner discriminate by reason of race, gender, creed, color, sexual orientation, gender identity or expression, or in violation of the PHRA and applicable federal laws, against or intimidate any employee involved in the manufacture of supplies, the performance of work, or any other activity required under the contract.

3. Neither the Contractor nor any subcontractor nor any person on their behalf shall in any manner discriminate by reason of race, gender, creed, color, sexual orientation, gender identity or expression, or in violation of the PHRA and applicable federal laws, in the provision of services under the contract.

4. Neither the Contractor nor any subcontractor nor any person on their behalf shall in any manner

discriminate against employees by reason of participation in or decision to refrain from participating in labor activities protected under the *Public Employee Relations Act*, *Pennsylvania Labor Relations Act* or *National Labor Relations Act*, as applicable and to the extent determined by entities charged with such Acts' enforcement, and shall comply with any provision of law establishing organizations as employees' exclusive representatives.

5. The Contractor and each subcontractor shall establish and maintain a written nondiscrimination and sexual harassment policy and shall inform their employees in writing of the policy. The policy must contain a provision that sexual harassment will not be tolerated and employees who practice it will be disciplined. Posting this Nondiscrimination/Sexual Harassment Clause conspicuously in easily-accessible and well-lighted places customarily frequented by employees and at or near where the contracted services are performed shall satisfy this requirement for employees with an established work site.

6. The Contractor and each subcontractor shall not discriminate by reason of race, gender, creed, color, sexual orientation, gender identity or expression, or in violation of PHRA and applicable federal laws, against any subcontractor or supplier who is qualified to perform the work to which the contract relates.

7. The Contractor and each subcontractor represents that it is presently in compliance with and will maintain compliance with all applicable federal, state, and local laws, regulations and policies relating to nondiscrimination and sexual harassment. The Contractor and each subcontractor further represents that it has filed a Standard Form 100 Employer Information Report ("EEO-1") with the U.S. Equal Employment Opportunity Commission ("EEOC") and shall file an annual EEO-1 report with the EEOC as required for employers' subject to *Title VII of the Civil Rights Act of 1964*, as amended, that have 100 or more employees and employers that have federal government contracts or first-tier subcontracts and have 50 or more employees. The Contractor and each subcontractor shall, upon request and within the time periods requested by the Commonwealth, furnish all necessary employment documents and records, including EEO-1 reports, and permit access to their books, records, and accounts by the contracting agency and the Bureau of Diversity, Inclusion and Small Business Opportunities for purpose of ascertaining compliance with provisions of this Nondiscrimination/Sexual Harassment Clause.

8. The Contractor shall include the provisions of this Nondiscrimination/Sexual Harassment Clause in every subcontract so that those provisions applicable to subcontractors will be binding upon each subcontractor.

9. The Contractor's and each subcontractor's obligations pursuant to these provisions are ongoing from and after the effective date of the contract through the termination date thereof. Accordingly, the Contractor and each subcontractor shall have an obligation to inform the Commonwealth if, at any time during the term of the contract, it becomes aware of any actions or occurrences that would result in violation of these provisions.

10. The Commonwealth may cancel or terminate the contract and all money due or to become due under the contract may be forfeited for a violation of the terms and conditions of this Nondiscrimination/Sexual Harassment Clause. In addition, the agency may proceed with debarment or suspension and may place the Contractor in the Contractor Responsibility File.

### **V.36 CONTRACT-028.1 Contractor Integrity Provisions (January 2015)**

It is essential that those who seek to contract with the Commonwealth of Pennsylvania ("Commonwealth") observe high standards of honesty and integrity. They must conduct themselves in a manner that fosters public confidence in the integrity of the Commonwealth contracting and procurement process.

**1. DEFINITIONS.** For purposes of these Contractor Integrity Provisions, the following terms shall have the meanings found in this Section:

**a. "Affiliate"** means two or more entities where (a) a parent entity owns more than fifty percent of the voting stock of each of the entities; or (b) a common shareholder or group of shareholders owns more than fifty percent of the voting stock of each of the entities; or (c) the entities have a common proprietor or general partner.

**b. "Consent"** means written permission signed by a duly authorized officer or employee of the Commonwealth, provided that where the material facts have been disclosed, in writing, by prequalification, bid, proposal, or contractual terms, the Commonwealth shall be deemed to have consented by virtue of the execution of this contract.

**c. "Contractor"** means the individual or entity, that has entered into this contract with the Commonwealth.

**d. "Contractor Related Parties"** means any affiliates of the Contractor and the Contractor's executive officers, Pennsylvania officers and directors, or owners of 5 percent or more interest in the Contractor.

**e. "Financial Interest"** means either:

(1) Ownership of more than a five percent interest in any business; or

(2) Holding a position as an officer, director, trustee, partner, employee, or holding any position of management.

**f. "Gratuity"** means tendering, giving, or providing anything of more than nominal monetary value including, but not limited to, cash, travel, entertainment, gifts, meals, lodging, loans, subscriptions, advances, deposits of money, services, employment, or contracts of any kind. The exceptions set forth in the *Governor's Code of Conduct, Executive Order 1980-18*, the *4 Pa. Code §7.153(b)*, shall apply.

**g. "Non-bid Basis"** means a contract awarded or executed by the Commonwealth with Contractor without seeking bids or proposals from any other potential bidder or offeror.

2. In furtherance of this policy, Contractor agrees to the following:

**a.** Contractor shall maintain the highest standards of honesty and integrity during the performance of this contract and shall take no action in violation of state or federal laws or regulations or any other applicable laws or regulations, or other requirements applicable to Contractor or that govern contracting or procurement with the Commonwealth.

**b.** Contractor shall establish and implement a written business integrity policy, which includes, at a minimum, the requirements of these provisions as they relate to the Contractor activity with the Commonwealth and Commonwealth employees and which is made known to all Contractor employees. Posting these Contractor Integrity Provisions conspicuously in easily-accessible and well-lighted places customarily frequented by employees and at or near where the contract services are performed shall satisfy this requirement.

**c.** Contractor, its affiliates, agents, employees and anyone in privity with Contractor shall not accept, agree to give, offer, confer or agree to confer or promise to confer, directly or indirectly, any gratuity or pecuniary benefit to any person, or to influence or attempt to influence any person in violation of any federal or state law, regulation, executive order of the Governor of Pennsylvania, statement of policy, management directive or any other published standard of the Commonwealth in connection with performance of work under this contract, except as provided in this contract.

**d.** Contractor shall not have a financial interest in any other contractor, subcontractor, or supplier providing services, labor or material under this contract, unless the financial interest is disclosed to the Commonwealth in writing and the Commonwealth consents to Contractor's financial interest prior to Commonwealth execution of the contract. Contractor shall disclose the financial interest to the Commonwealth at the time of bid or proposal submission, or if no bids or proposals are solicited, no later than the Contractor's submission of the contract signed by Contractor.

**e.** Contractor certifies to the best of its knowledge and belief that within the last five (5) years Contractor or Contractor Related Parties have not:

(1) been indicted or convicted of a crime involving moral turpitude or business honesty or integrity in any jurisdiction;

(2) been suspended, debarred or otherwise disqualified from entering into any contract with any governmental agency;

- (3) had any business license or professional license suspended or revoked;
- (4) had any sanction or finding of fact imposed as a result of a judicial or administrative proceeding related to fraud, extortion, bribery, bid rigging, embezzlement, misrepresentation or anti-trust; and
- (5) been, and is not currently, the subject of a criminal investigation by any federal, state or local prosecuting or investigative agency and/or civil anti-trust investigation by any federal, state or local prosecuting or investigative agency.

If Contractor cannot so certify to the above, then it must submit along with its bid, proposal or contract a written explanation of why such certification cannot be made and the Commonwealth will determine whether a contract may be entered into with the Contractor. The Contractor's obligation pursuant to this certification is ongoing from and after the effective date of the contract through the termination date thereof. Accordingly, the Contractor shall have an obligation to immediately notify the Commonwealth in writing if at any time during the term of the contract it becomes aware of any event which would cause the Contractor's certification or explanation to change. Contractor acknowledges that the Commonwealth may, in its sole discretion, terminate the contract for cause if it learns that any of the certifications made herein are currently false due to intervening factual circumstances or were false or should have been known to be false when entering into the contract.

f. Contractor shall comply with the requirements of the *Lobbying Disclosure Act (65 Pa.C.S. §13A01 et seq.)* regardless of the method of award. If this contract was awarded on a Non-bid Basis, Contractor must also comply with the requirements of the *Section 1641 of the Pennsylvania Election Code (25 P.S. §3260a)*.

g. When contractor has reason to believe that any breach of ethical standards as set forth in law, the Governor's Code of Conduct, or these Contractor Integrity Provisions has occurred or may occur, including but not limited to contact by a Commonwealth officer or employee which, if acted upon, would violate such ethical standards, Contractor shall immediately notify the Commonwealth contracting officer or the Office of the State Inspector General in writing.

h. Contractor, by submission of its bid or proposal and/or execution of this contract and by the submission of any bills, invoices or requests for payment pursuant to the contract, certifies and represents that it has not violated any of these Contractor Integrity Provisions in connection with the submission of the bid or proposal, during any contract negotiations or during the term of the contract, to include any extensions thereof. Contractor shall immediately notify the Commonwealth in writing of any actions for occurrences that would result in a violation of these Contractor Integrity Provisions. Contractor agrees to reimburse the Commonwealth for the reasonable costs of investigation incurred by the Office of the State Inspector General for investigations of the Contractor's compliance with the terms of this or any other agreement between the Contractor and the Commonwealth that results in the suspension or debarment of the Contractor. Contractor shall not be responsible for investigative costs for investigations that do not result in the Contractor's suspension or debarment.

i. Contractor shall cooperate with the Office of the State Inspector General in its investigation of any alleged Commonwealth agency or employee breach of ethical standards and any alleged Contractor non-compliance with these Contractor Integrity Provisions. Contractor agrees to make identified Contractor employees available for interviews at reasonable times and places. Contractor, upon the inquiry or request of an Inspector General, shall provide, or if appropriate, make promptly available for inspection or copying, any information of any type or form deemed relevant by the Office of the State Inspector General to Contractor's integrity and compliance with these provisions. Such information may include, but shall not be limited to, Contractor's business or financial records, documents or files of any type or form that refer to or concern this contract. Contractor shall incorporate this paragraph in any agreement, contract or subcontract it enters into in the course of the performance of this contract/agreement solely for the purpose of obtaining subcontractor compliance with this provision. The incorporation of this provision in a subcontract shall not create privity of contract between the Commonwealth and any such subcontractor, and no third party beneficiaries shall be created thereby.

j. For violation of any of these Contractor Integrity Provisions, the Commonwealth may terminate this and any other contract with Contractor, claim liquidated damages in an amount equal to the value of anything received in breach of these Provisions, claim damages for all additional costs and expenses incurred in obtaining another contractor to complete performance under this contract, and debar and suspend Contractor from doing business with

the Commonwealth. These rights and remedies are cumulative, and the use or non-use of any one shall not preclude the use of all or any other. These rights and remedies are in addition to those the Commonwealth may have under law, statute, regulation or otherwise.

### **V.37 CONTRACT-029.1 Contractor Responsibility Provisions (July 2021)**

For the purpose of these provisions, the term Contractor is defined as any person, including, but not limited to, a bidder, offeror, loan recipient, grantee or lessor, who has furnished or performed or seeks to furnish or perform, goods, supplies, services, leased space, construction or other activity, under a contract, grant, lease, purchase order or reimbursement agreement with the Commonwealth of Pennsylvania (Commonwealth). The term Contractor includes a permittee, licensee, or any agency, political subdivision, instrumentality, public authority, or other public entity in the Commonwealth.

1. The Contractor certifies, in writing, for itself and its subcontractors required to be disclosed or approved by the Commonwealth, that as of the date of its execution of this Bid/Contract, that neither the Contractor, nor any such subcontractors, are under suspension or debarment by the Commonwealth or any governmental entity, instrumentality, or authority and, if the Contractor cannot so certify, then it agrees to submit, along with its Bid/Contract, a written explanation of why such certification cannot be made.

2. The Contractor also certifies, in writing, that as of the date of its execution of this Bid/Contract it has no tax liabilities or other Commonwealth obligations, or has filed a timely administrative or judicial appeal if such liabilities or obligations exist, or is subject to a duly approved deferred payment plan if such liabilities exist.

3. The Contractor's obligations pursuant to these provisions are ongoing from and after the effective date of the Contract through the termination date thereof. Accordingly, the Contractor shall have an obligation to inform the Commonwealth if, at any time during the term of the Contract, it becomes delinquent in the payment of taxes, or other Commonwealth obligations, or if it or, to the best knowledge of the Contractor, any of its subcontractors are suspended or debarred by the Commonwealth, the federal government, or any other state or governmental entity. Such notification shall be made within 15 days of the date of suspension or debarment.

4. The failure of the Contractor to notify the Commonwealth of its suspension or debarment by the Commonwealth, any other state, or the federal government shall constitute an event of default of the Contract with the Commonwealth.

5. The Contractor agrees to reimburse the Commonwealth for the reasonable costs of investigation incurred by the Office of State Inspector General for investigations of the Contractor's compliance with the terms of this or any other agreement between the Contractor and the Commonwealth that results in the suspension or debarment of the contractor. Such costs shall include, but shall not be limited to, salaries of investigators, including overtime; travel and lodging expenses; and expert witness and documentary fees. The Contractor shall not be responsible for investigative costs for investigations that do not result in the Contractor's suspension or debarment.

6. The Contractor may search the current list of suspended and debarred Commonwealth contractors by visiting the eMarketplace website at <http://www.emarketplace.state.pa.us> and clicking the Debarment List tab.

### **V.38 CONTRACT-030.1 Americans with Disabilities Act (July 2021)**

For the purpose of these provisions, the term contractor is defined as any person, including, but not limited to, a bidder, offeror, supplier, or grantee, who will furnish or perform or seeks to furnish or perform, goods, supplies, services, construction or other activity, under a purchase order, contract, or grant with the Commonwealth of Pennsylvania (Commonwealth).

During the term of this agreement, the contractor agrees as follows:

- 1 Pursuant to federal regulations promulgated under the authority of the Americans with Disabilities Act, 28 C. F. R. § 35.101 et seq., the contractor understands and agrees that no individual with a disability shall, on the basis of the disability, be excluded from participation in this agreement or from

activities provided for under this agreement. As a condition of accepting and executing this agreement, the contractor agrees to comply with the "General Prohibitions Against Discrimination," 28 C. F. R. § 35.130, and all other regulations promulgated under Title II of the Americans with Disabilities Act which are applicable to the benefits, services, programs, and activities provided by the Commonwealth through contracts with outside contractors.

- 2 The contractor shall be responsible for and agrees to indemnify and hold harmless the Commonwealth from all losses, damages, expenses, claims, demands, suits, and actions brought by any party against the Commonwealth as a result of the contractor's failure to comply with the provisions of paragraph 1.

### **V.39 CONTRACT-031.1 Hazardous Substances (April 2017)**

The Contractor shall provide information to the Commonwealth about the identity and hazards of hazardous substances supplied or used by the Contractor in the performance of the Contract. The Contractor must comply with Act 159 of October 5, 1984, known as the "Worker and Community Right to Know Act" (the "Act") and the regulations promulgated pursuant thereto at 34 Pa. Code Section 301.1 - 323.6.

a. Labeling. The Contractor shall ensure that each individual product (as well as the carton, container or package in which the product is shipped) of any of the following substances (as defined by the Act and the regulations) supplied by the Contractor is clearly labeled, tagged or marked with the information listed in Subparagraphs (1) through (4):

1) Hazardous substances:

- a) The chemical name or common name,
- b) A hazard warning, and
- c) The name, address, and telephone number of the manufacturer.

2) Hazardous mixtures:

- a) The common name, but if none exists, then the trade name,
- b) The chemical or common name of special hazardous substances comprising .01% or more of the mixture,
- c) The chemical or common name of hazardous substances consisting 1.0% or more of the mixture,
- d) A hazard warning, and
- e) The name, address, and telephone number of the manufacturer.

3) Single chemicals:

- a) The chemical name or the common name,
- b) A hazard warning, if appropriate, and
- c) The name, address, and telephone number of the manufacturer.

4) Chemical Mixtures:

- a) The common name, but if none exists, then the trade name,
- b) A hazard warning, if appropriate,
- c) The name, address, and telephone number of the manufacturer, and

d) The chemical name or common name of either the top five substances by volume or those substances consisting of 5.0% or more of the mixture.

A common name or trade name may be used only if the use of the name more easily or readily identifies the true nature of the hazardous substance, hazardous mixture, single chemical, or mixture involved.

Container labels shall provide a warning as to the specific nature of the hazard arising from the substance in the container.

The hazard warning shall be given in conformity with one of the nationally recognized and accepted systems of providing warnings, and hazard warnings shall be consistent with one or more of the recognized systems throughout the workplace. Examples are:

- NFPA 704, Identification of the Fire Hazards of Materials.
- National Paint and Coatings Association: Hazardous Materials Identification System.
- American Society for Testing and Materials, Safety Alert Pictorial Chart.
- American National Standard Institute, Inc., for the Precautionary Labeling of Hazardous Industrial Chemicals.

Labels must be legible and prominently affixed to and displayed on the product and the carton, container, or package so that employees can easily identify the substance or mixture present therein.

b. Material Safety Data Sheet. The contractor shall provide Material Safety Data Sheets (MSDS) with the information required by the Act and the regulations for each hazardous substance or hazardous mixture. The Commonwealth must be provided an appropriate MSDS with the initial shipment and with the first shipment after an MSDS is updated or product changed. For any other chemical, the contractor shall provide an appropriate MSDS, if the manufacturer, importer, or supplier produces or possesses the MSDS. The contractor shall also notify the Commonwealth when a substance or mixture is subject to the provisions of the Act. Material Safety Data Sheets may be attached to the carton, container, or package mailed to the Commonwealth at the time of shipment.

#### **V.40 CONTRACT-032.1 Covenant Against Contingent Fees (Oct 2006)**

The Contractor warrants that no person or selling agency has been employed or retained to solicit or secure the Contract upon an agreement or understanding for a commission, percentage, brokerage, or contingent fee, except bona fide employees or bona fide established commercial or selling agencies maintained by the Contractor for the purpose of securing business. For breach or violation of this warranty, the Commonwealth shall have the right to terminate the Contract without liability or in its discretion to deduct from the Contract price or consideration, or otherwise recover the full amount of such commission, percentage, brokerage, or contingent fee.

#### **V.41 CONTRACT-033.1 Applicable Law (Oct 2006)**

This Contract shall be governed by and interpreted and enforced in accordance with the laws of the Commonwealth of Pennsylvania (without regard to any conflict of laws provisions) and the decisions of the Pennsylvania courts. The Contractor consents to the jurisdiction of any court of the Commonwealth of Pennsylvania and any federal courts in Pennsylvania, waiving any claim or defense that such forum is not convenient or proper. The Contractor agrees that any such court shall have in personam jurisdiction over it, and consents to service of process in any manner authorized by Pennsylvania law.

#### **V.42 CONTRACT- 034.1b Integration (Nov 30 2006)**

This Contract, including the Invitation for Bids, the Contractor's bid, all referenced documents, and any Purchase Order constitutes the entire agreement between the parties. No agent, representative, employee or officer of either the Commonwealth or the Contractor has authority to make, or has made, any statement, agreement or representation, oral or written, in connection with the Contract, which in any way can be deemed to modify, add to or detract from, or otherwise change or alter its terms and conditions. No negotiations between the parties, nor any custom or usage, shall be permitted to modify or contradict any of the terms and conditions of the Contract. No modifications, alterations, changes, or waiver to the Contract or any of its terms shall be valid or binding unless accomplished by a written amendment signed by both parties.

#### **V.43 CONTRACT-034.2b Order of Precedence - IFB (Dec 6 2006)**

In the event there is a conflict among the documents comprising this Contract, the Commonwealth and the Contractor agree on the following order of precedence: the Contract; the IFB; and the Contractor's Bid in Response to the IFB.

#### **V.44 CONTRACT-034.3 Controlling Terms and Conditions (Aug 2011)**

The terms and conditions of this Contract shall be the exclusive terms of agreement between the Contractor and the Commonwealth. All quotations requested and received from the Contractor are for obtaining firm pricing only. Other terms and conditions or additional terms and conditions included or referenced in the Contractor's quotations, invoices, business forms, or other documentation shall not become part of the parties' agreement and shall be disregarded by the parties, unenforceable by the Contractor and not binding on the Commonwealth.

#### **V.45 CONTRACT-035.1a Changes (Oct 2006)**

The Commonwealth reserves the right to make changes at any time during the term of the Contract or any renewals or extensions thereof: 1) to increase or decrease the quantities resulting from variations between any estimated quantities in the Contract and actual quantities; 2) to make changes to the services within the scope of the Contract; 3) to notify the Contractor that the Commonwealth is exercising any Contract renewal or extension option; or 4) to modify the time of performance that does not alter the scope of the Contract to extend the completion date beyond the Expiration Date of the Contract or any renewals or extensions thereof. Any such change shall be made by the Contracting Officer by notifying the Contractor in writing. The change shall be effective as of the date of the change, unless the notification of change specifies a later effective date. Such increases, decreases, changes, or modifications will not invalidate the Contract, nor, if performance security is being furnished in conjunction with the Contract, release the security obligation. The Contractor agrees to provide the service in accordance with the change order. Any dispute by the Contractor in regard to the performance required by any notification of change shall be handled through Contract Controversies Provision.

#### **V.46 CONTRACT-037.1a Confidentiality (Oct 2013)**

(a) The Contractor agrees to protect the confidentiality of the Commonwealth's confidential information. The Commonwealth agrees to protect the confidentiality of Contractor's confidential information. In order for information to be deemed confidential, the party claiming confidentiality must designate the information as "confidential" in such a way as to give notice to the other party (notice may be communicated by describing the information, and the specifications around its use or disclosure, in the SOW). Neither party may assert that information owned by the other party is such party's confidential information. The parties agree that such confidential information shall not be copied, in whole or in part, or used or disclosed except when essential for authorized activities under this Contract and, in the case of disclosure, where the recipient of the confidential information has agreed to be bound by confidentiality requirements no less restrictive than those set forth herein. Each copy of such confidential information shall be marked by the party making the copy with any notices appearing in the original. Upon termination or cancellation of this Contract or any license granted hereunder, the receiving party will return to the disclosing party all copies of the confidential information in the receiving party's possession, other than one copy, which may be maintained for archival purposes only, and which will remain subject to this Contract's security, privacy, data retention/destruction and confidentiality provisions (all of which shall survive the expiration of this Contract). Both parties agree that a material breach of these requirements may, after failure to cure within the time frame specified in this Contract, and at the discretion of the non-breaching party, result in termination for default pursuant to the DEFAULT provision of this Contract, in addition to other remedies available to the non-breaching party.

(b) Insofar as information is not otherwise protected by law or regulation, the obligations stated in this Section do not apply to information:



- (1) already known to the recipient at the time of disclosure other than through the contractual relationship;
- (2) independently generated by the recipient and not derived by the information supplied by the disclosing party.
- (3) known or available to the public , except where such knowledge or availability is the result of unauthorized disclosure by the recipient of the proprietary information;
- (4) disclosed to the recipient without a similar restriction by a third party who has the right to make such disclosure; or
- (5) required to be disclosed by law , regulation, court order, or other legal process.

There shall be no restriction with respect to the use or disclosure of any ideas, concepts, know-how, or data processing techniques developed alone or jointly with the Commonwealth in connection with services provided to the Commonwealth under this Contract.

(c) The Contractor shall use the following process when submitting information to the Commonwealth it believes to be confidential and/or proprietary information or trade secrets:

- (1) Prepare an un-redacted version of the appropriate document, and
- (2) Prepare a redacted version of the document that redacts the information that is asserted to be confidential or proprietary information or a trade secret, and
- (3) Prepare a signed written statement that states:
  - (i) the attached document contains confidential or proprietary information or trade secrets;
  - (ii) the Contractor is submitting the document in both redacted and un-redacted format in accordance with 65 P.S. § 67.707(b); and
  - (iii) the Contractor is requesting that the document be considered exempt under 65 P.S. § 67.708(b)(11) from public records requests.
- (4) Submit the two documents along with the signed written statement to the Commonwealth.

#### **V.47 CONTRACT-046.1 Manufacturer's Price Reduction (Oct 2006)**

If, prior to the delivery of the awarded item(s) by the Contractor, a price reduction is announced by the original equipment manufacturer, a comparative price reduction will be given to the Commonwealth by the Contractor.

#### **V.48 CONTRACT-047.1 Motor Vehicles to be manufactured in North America (Oct 2006)**

All motor vehicles furnished by the Contractor pursuant to the Contract must be manufactured in North America. North America is defined as the United States, Canada, and Mexico. A motor vehicle is manufactured in North America if a substantial majority of the principal components are assembled into the final products in an assembly plant in North America. The Contractor shall be prepared to prove that the motor vehicles that will be, or have been, furnished to the Commonwealth will be or are, in fact, manufactured in North America in accordance with Sections 3731-3736 of the Commonwealth Procurement Code (62 Pa. C.S. Sections 3731-3736), known as the Motor Vehicle Procurement Act. No payment shall be made to the Contractor unless the Commonwealth is satisfied that the Contractor has complied with these provisions and the Motor Vehicle Procurement Act. Any payments made to the Contractor, which should not have been made, shall be recoverable directly from the Contractor. In addition to the withholding of payments, any person who willfully violates any of the provisions of the Motor Vehicle Procurement Act may be prohibited by any public agency from participation in Contracts awarded by the public agency for a period of five years from the date of determination that a violation has occurred.

**V.49 CONTRACT-047.2b General Delivery Requirements for Vehicles (Oct 2012)**

The Contractor must supply the contracted vehicles that are to be delivered to the Commonwealth of Pennsylvania in accordance with the specifications attached to this IFB and any Pennsylvania Commercial Item Descriptions referenced in the specifications and attached to this IFB.

**V.50 CONTRACT-047.5 Local Public Procurement Unit Participation (March 5, 2007)**

Any questions or problems pertaining to acquisition of vehicles by participating Local Public Procurement Units and their use of the Contract should be accomplished in a timely manner and all contact pertaining to these questions or problems should be directed to the Bureau of Procurement, Department of General Services to the attention of the commodity specialist assigned to this contract.

**V.51 CONTRACT-047.6 Additional Delivery Charges (Participating Local Public Procurement Units ONLY) (Oct 2006)**

Participating Local Public Procurement Units will pick up ordered equipment at the Contractor(s)'s place of business or have the equipment delivered by the Contractor for an additional **CHARGE PER VEHICLE of \$0.00** .

**V.52 CONTRACT-047.7 Taxes (Oct 2006)**

All participating Local Public Procurement Units will be required to indicate on their purchase orders the Internal Revenue Service Registration Number for exemption from Federal Excise Tax, if applicable.

**V.53 CONTRACT-051.1 Notice (Dec 2006)**

Any written notice to any party under this Contract shall be deemed sufficient if delivered personally, or by facsimile, teletype, electronic or digital transmission (provided such delivery is confirmed), or by a recognized overnight courier service (e.g., DHL, Federal Express, etc.) with confirmed receipt, or by certified or registered United States mail, postage prepaid, return receipt requested, and sent to following:

- a. If to the Contractor: the Contractor's address as recorded in the Commonwealth's Supplier Registration system.
- b. If to the Commonwealth: the address of the Issuing Office as set forth on the Contract.

**V.54 CONTRACT-052.1 Right to Know Law (Feb 2010)**

a. The Pennsylvania Right-to-Know Law, 65 P.S. §§ 67.101-3104, ("RTKL") applies to this Contract. For the purpose of these provisions, the term "the Commonwealth" shall refer to the contracting Commonwealth agency.

b. If the Commonwealth needs the Contractor's assistance in any matter arising out of the RTKL related to this Contract, it shall notify the Contractor using the legal contact information provided in this Contract. The Contractor, at any time, may designate a different contact for such purpose upon reasonable prior written notice to the Commonwealth.

c. Upon written notification from the Commonwealth that it requires the Contractor's assistance in responding to a request under the RTKL for information related to this Contract that may be in the Contractor's possession, constituting, or alleged to constitute, a public record in accordance with the RTKL ("Requested Information"), the Contractor shall:

1. Provide the Commonwealth, within ten (10) calendar days after receipt of written notification, access to, and copies of, any document or information in the Contractor's possession arising out of this Contract that the Commonwealth reasonably believes is Requested Information and may be a public record under the RTKL; and
2. Provide such other assistance as the Commonwealth may reasonably request, in order to comply with the RTKL with respect to this Contract.

d. If the Contractor considers the Requested Information to include a request for a Trade Secret or Confidential Proprietary Information, as those terms are defined by the RTKL, or other information that the Contractor considers exempt from production under the RTKL, the Contractor must notify the Commonwealth and provide, within seven (7) calendar days of receiving the written notification, a written statement signed by a representative of the

Contractor explaining why the requested material is exempt from public disclosure under the RTKL.

e. The Commonwealth will rely upon the written statement from the Contractor in denying a RTKL request for the Requested Information unless the Commonwealth determines that the Requested Information is clearly not protected from disclosure under the RTKL. Should the Commonwealth determine that the Requested Information is clearly not exempt from disclosure, the Contractor shall provide the Requested Information within five (5) business days of receipt of written notification of the Commonwealth's determination.

f. If the Contractor fails to provide the Requested Information within the time period required by these provisions, the Contractor shall indemnify and hold the Commonwealth harmless for any damages, penalties, costs, detriment or harm that the Commonwealth may incur as a result of the Contractor's failure, including any statutory damages assessed against the Commonwealth.

g. The Commonwealth will reimburse the Contractor for any costs associated with complying with these provisions only to the extent allowed under the fee schedule established by the Office of Open Records or as otherwise provided by the RTKL if the fee schedule is inapplicable.

h. The Contractor may file a legal challenge to any Commonwealth decision to release a record to the public with the Office of Open Records, or in the Pennsylvania Courts, however, the Contractor shall indemnify the Commonwealth for any legal expenses incurred by the Commonwealth as a result of such a challenge and shall hold the Commonwealth harmless for any damages, penalties, costs, detriment or harm that the Commonwealth may incur as a result of the Contractor's failure, including any statutory damages assessed against the Commonwealth, regardless of the outcome of such legal challenge. As between the parties, the Contractor agrees to waive all rights or remedies that may be available to it as a result of the Commonwealth's disclosure of Requested Information pursuant to the RTKL.

i. The Contractor's duties relating to the RTKL are continuing duties that survive the expiration of this Contract and shall continue as long as the Contractor has Requested Information in its possession.