

- NOTES:
1. ALL DIMENSIONS ARE IN INCHES.
 2. MATERIAL: CARBON STEEL AISI 1080-1085 BRINELL HARDNESS 250-325*

EACH BLADE SECTION SHALL BE PUNCHED WITH A DATE OF MANUFACTURE AND THE MANUFACTURER'S NAME.

*STEEL SPECIFICATION.

PA DEPARTMENT OF TRANSPORTATION REVISIONS			STEEL CUTTING EDGES FOR SNOW PLOWS		
NO.	DATE	BY	DRAWN BY	DLW	EQN-16A
1	06-14-07	KNH			
2	07-29-15	JJB			
3	08-09-18	KBD			

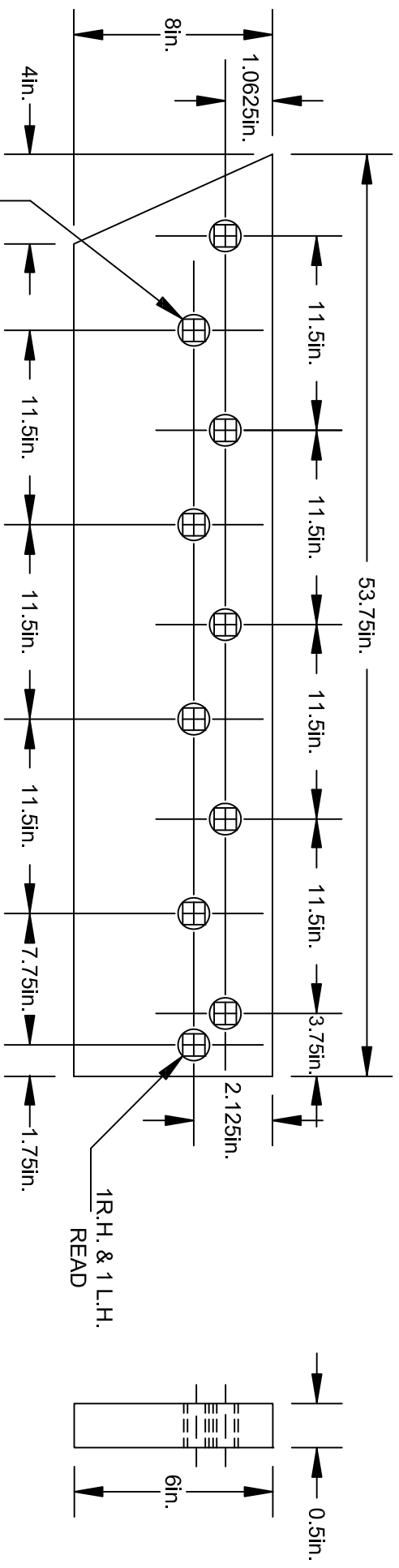

TEN (10) .6875in.
 SQUARE HOLES,
 COUNTERSUNK TO
 FIT .625in. DIA.
 PLOW BOLTS.

NOTES:

1. ALL DIMENSIONS ARE IN INCHES.
2. MATERIAL: CARBON STEEL AISI 1080-1085
 BRINELL HARDNESS 250-325*

EACH BLADE SECTION SHALL BE PUNCHED WITH A DATE OF
 MANUFACTURE AND THE MANUFACTURERS NAME.

*STEEL SPECIFICATION.

REVISIONS			DRAWN BY		DATE	
NO.	DATE	BY	DLW		02-06-96	
1	06-14-07	KNH	DLW		02-06-96	
2	07-29-15	JJB	DLW		02-06-96	
3	08-09-18	KBD	DLW		02-06-96	

PA DEPARTMENT OF TRANSPORTATION

**STEEL CUTTING EDGES FOR
 SNOW PLOWES**

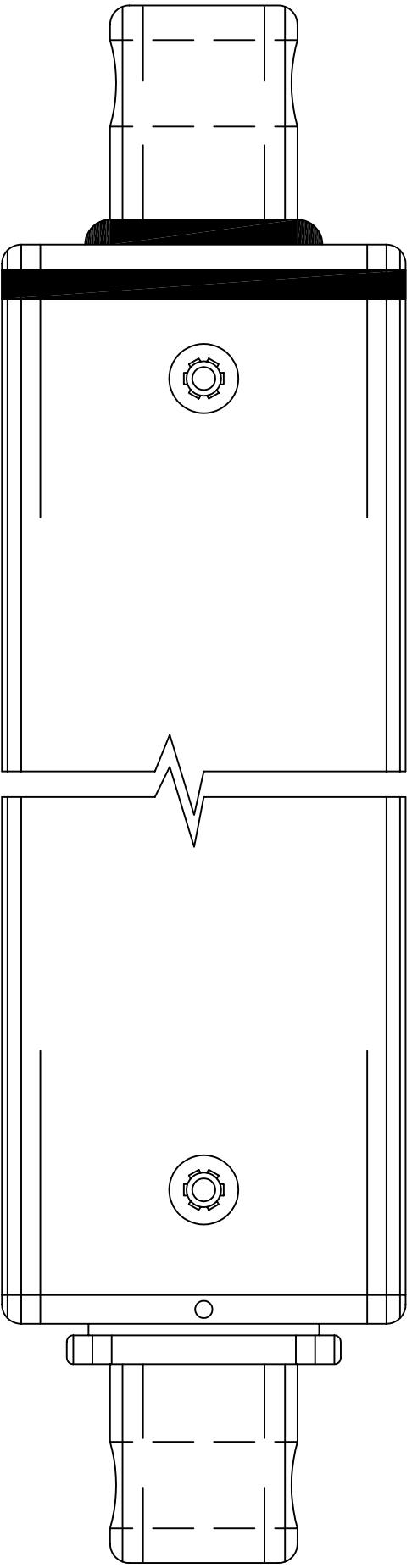

PA DEPARTMENT OF TRANSPORTATION

REVISIONS			PLOW RAM		
NO.	DATE	BY			

1							
2			DRAWN BY	CJW	SCALE	N/A	EQN-24
3			DATE	12-11-06	CHECKED BY	KGK	SHEET 1 OF 2
4							
5							

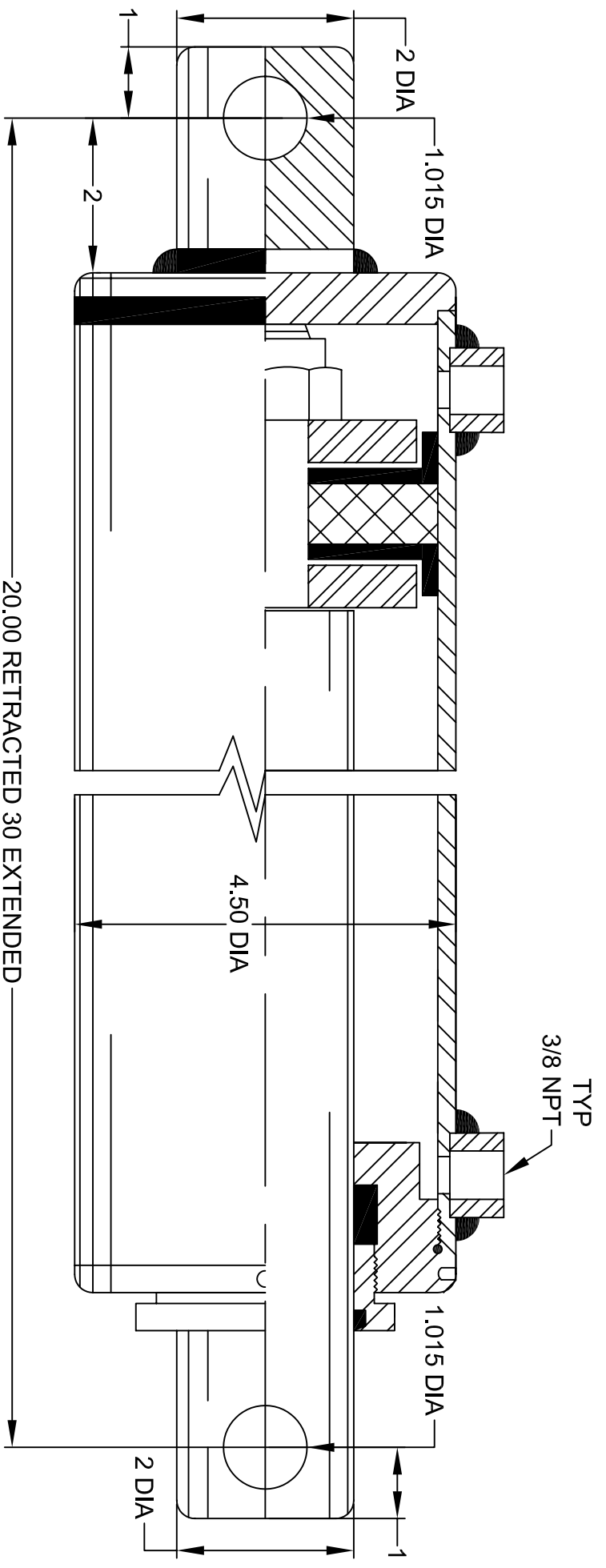

PA DEPARTMENT OF TRANSPORTATION

REVISIONS			PLOW RAM		
NO.	DATE	BY			
1					
2					
3					
4					
5					

NO.	DATE	BY			
1					
2					
3					
4					
5					

DRAWN BY: CJW SCALE: N/A EQN-24

DATE: 12-11-06 CHECKED BY: KGK SHEET 2 OF 2

AERIAL VIEW

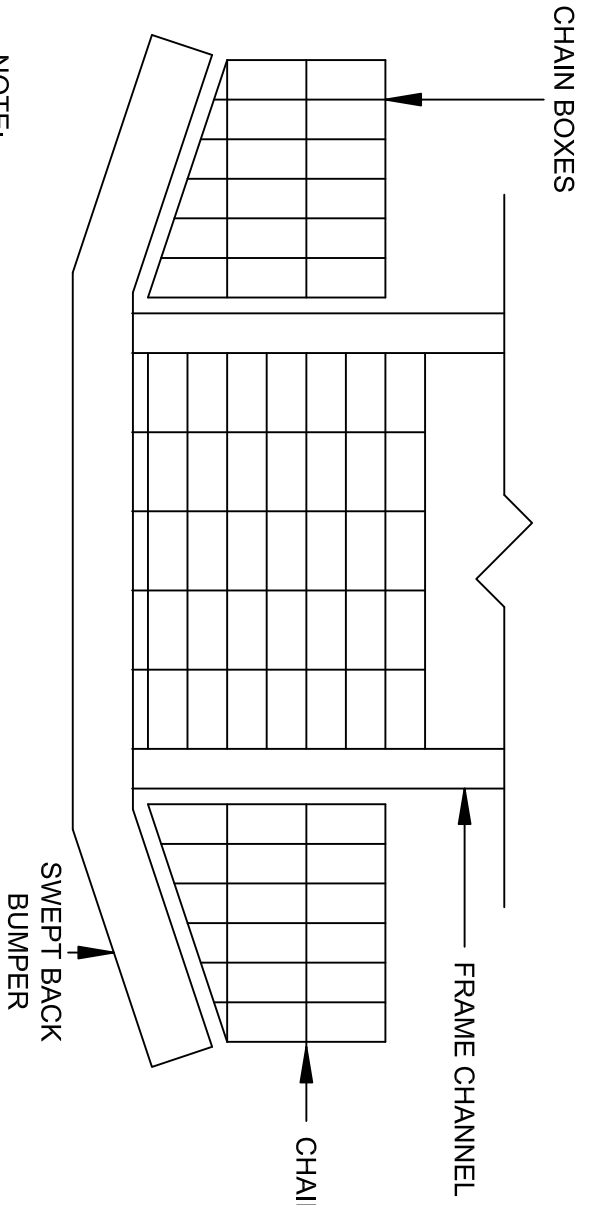

* LEFT SIDE BOX SHOWN, REVERSE FOR RIGHT SIDE.
 * GIVEN DIMENSIONS ARE APPROXIMATE AND MAY REQUIRE ALTERATION TO ADAPT TO MAKE / MODEL OF TRUCK AND STYLE OF BUMPER.

NOTE:
 THERE SHALL BE SUFFICIENT ALUMINUM BUSTIN TYPE MATERIAL TO COVER THE ENTIRE AREA FROM GRILL TO BUMPER AND FRAME RAIL TO FRAME RAIL.

ALUMINUM BUSTIN TYPE MATERIAL WELDED IN PLACE

LEFT SIDE FRONT VIEW

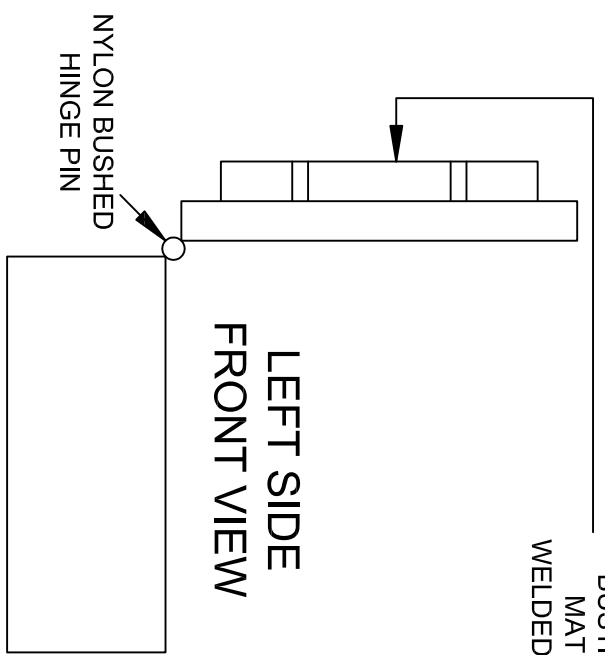

GRILL TO BUMPER AND BOXES SHALL BE SUPPORTED IN SUCH A WAY TO ENSURE SUPPORT OF A 200 lb. MAN IN ANY 12in. AREA.

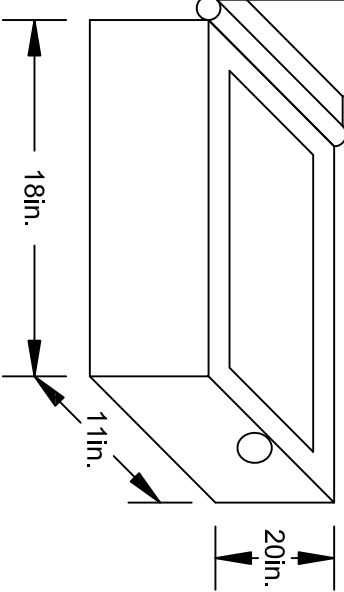
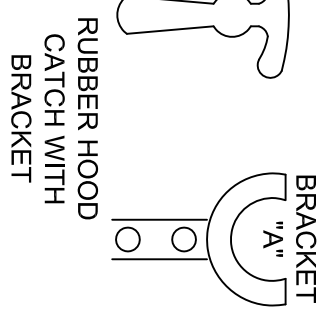
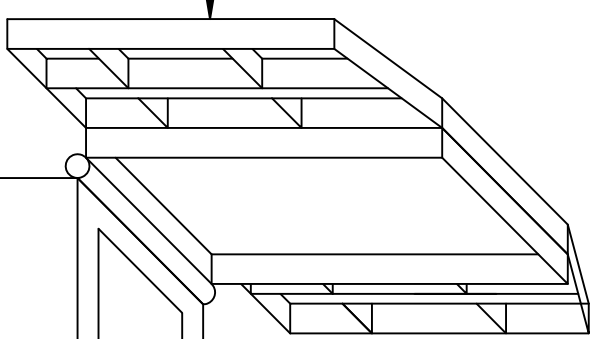

PA DEPARTMENT OF TRANSPORTATION

REVISIONS

NO.	DATE	BY	DWG	SCALE	EQU-32
1	05-22-02	KNH	KNH	N/A	EQU-32
2	07-17-07	KNH	KNH	N/A	EQU-32
3	07-24-18	KBD	KBD	N/A	EQU-32

DUMP TRUCK CHAIN BOXES

GRADE 8 BOLTS MINIMUM QUANTITY 4
 MINIMUM OF FOUR 0.75in. DRAIN HOLES

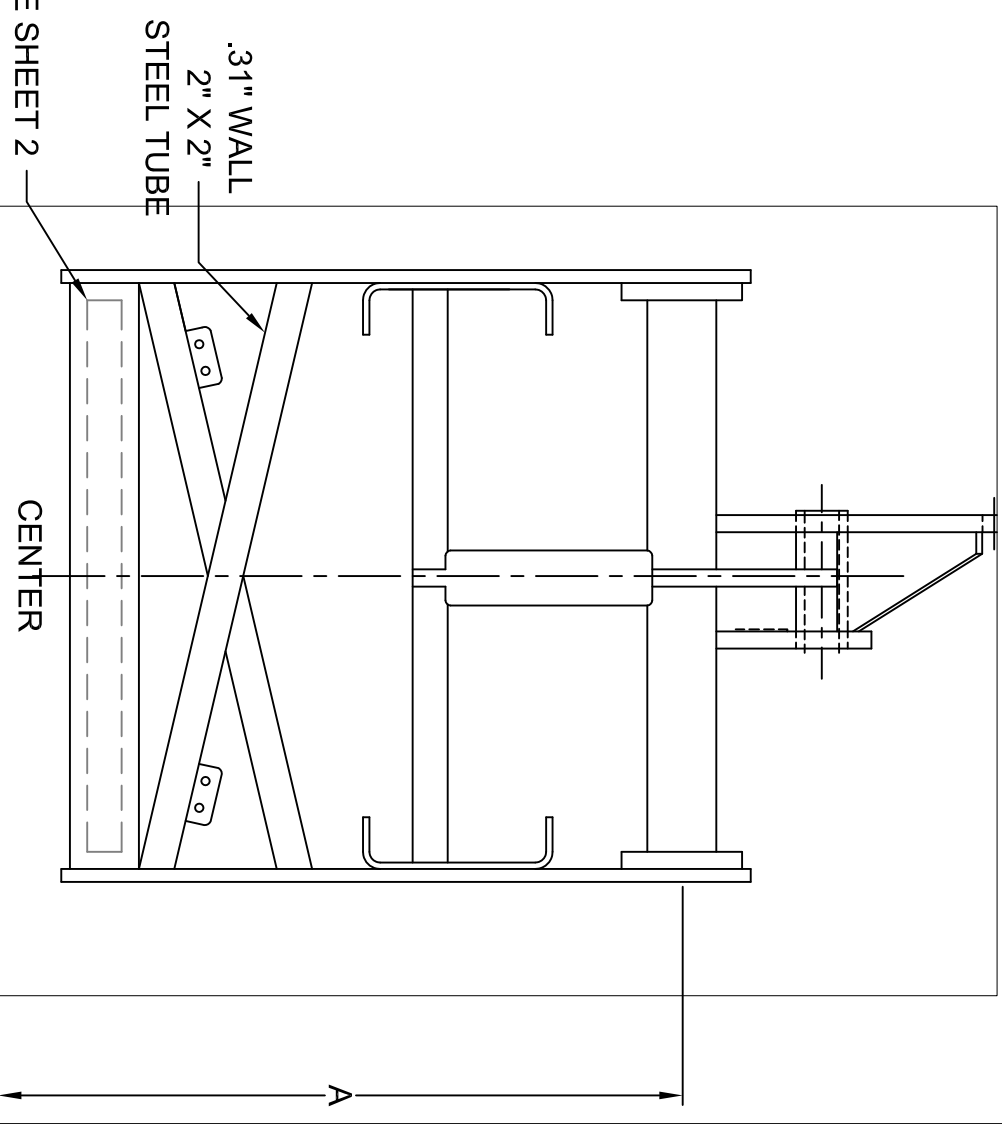
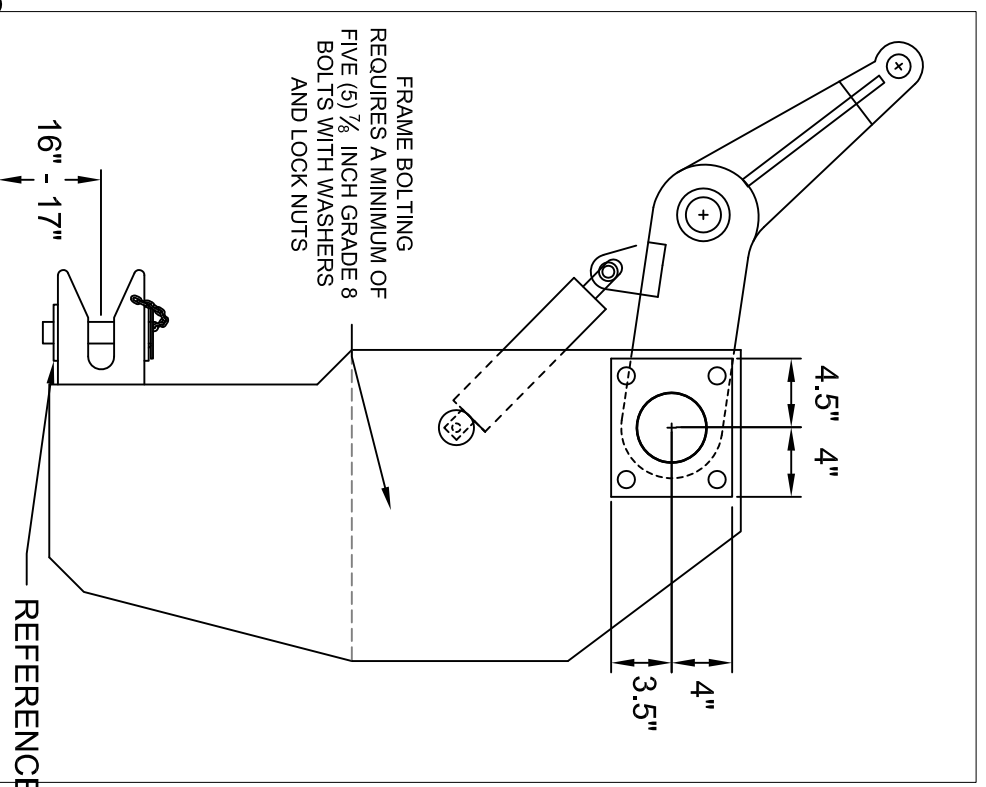

NOTES:

- ALL GREASE ZERKS SHALL BE SURROUNDED BY A SHORT LENGTH OF PIPE (WELDED IN PLACE) OR PLACED IN A RECESSED HOLE.
- "A" - HEIGHT SHALL BE SUFFICIENT TO AFFORD UNRESTRICTED LIFT FOR PENNDOT PLOWS. 16 INCH MINIMUM LIFT.
- ALL HYDRAULIC CONNECTIONS TO THE PLOW HOIST CYLINDER SHALL BE POSITIONED TO THE SIDES OR REAR TO PREVENT HOSE DAMAGE WHILE CONNECTING / DISCONNECTION TO THE FRONT PLOW.
- ALL FINAL DIMENSIONS AND ANGLES SHALL BE VERIFIED THROUGH FIELD VISITATIONS AND CORRESPONDING WITH THE FLEET MANAGEMENT DIVISION.

PA DEPARTMENT OF TRANSPORTATION

REVISIONS

NO.	DATE	BY	FRONT PLOW HITCH ASSEMBLY
1	04-27-15	GAW	
2	12-19-16	JJB	
3	08-02-18	KBD	

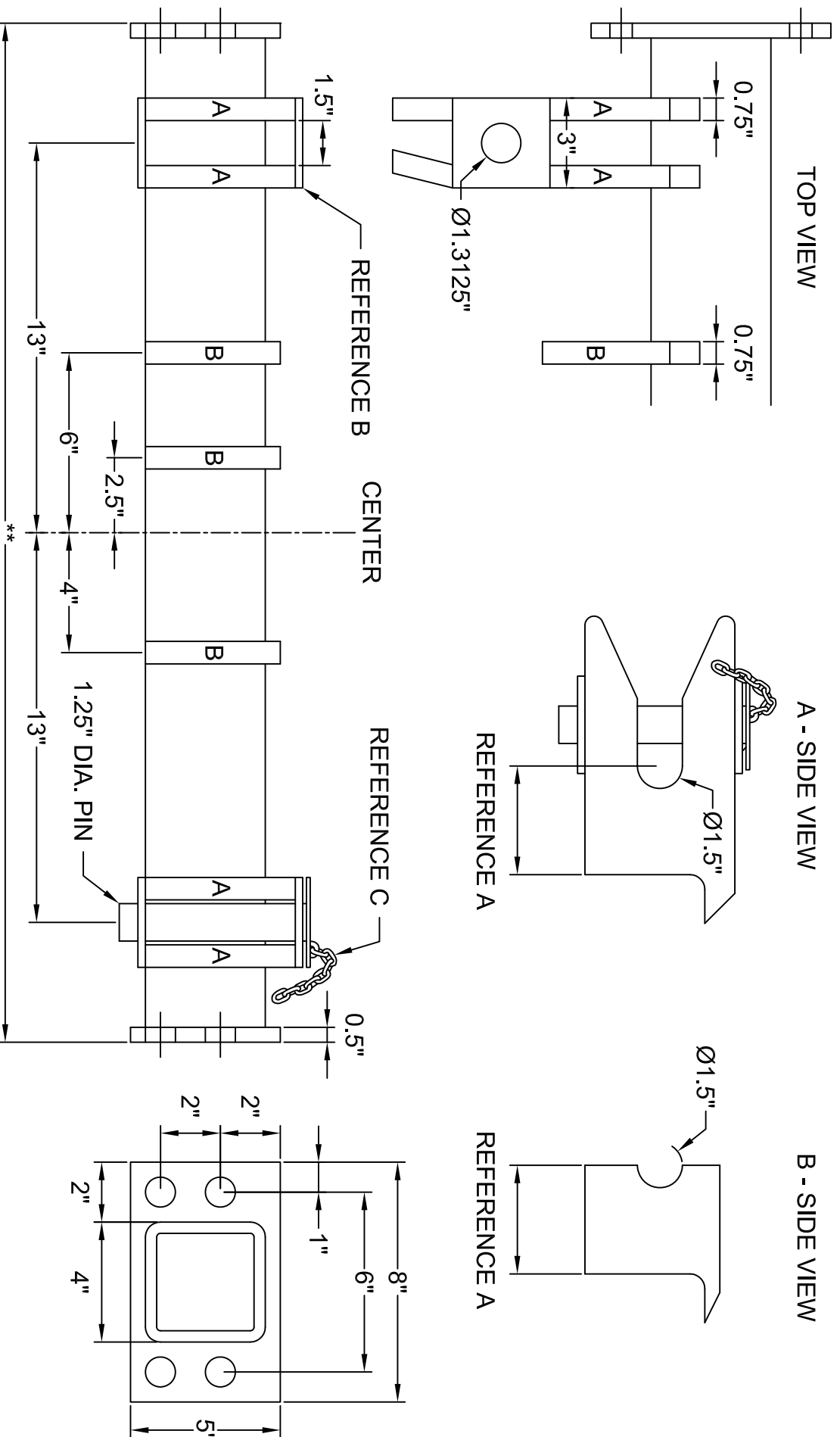

NOTES:

- A. CENTER SUPPORT RADIUS OF SUPPORT "A" SHALL BE IN DIRECT LINE WITH PLOW PUSH BAR.
- B. SUPPORT "A" SHALL HAVE 0.25" THICK PLATES ON TOP AND BOTTOM.
- C. PLOW PINS SHALL BE ATTACHED WITH CHAIN TO PLOW FRAME.

* VARIABLE WIDTH ASSEMBLY, CHECK CHASSIS FRAME RAIL WIDTH *
 ALL FINAL DIMENSIONS AND ANGLES SHALL BE VERIFIED THROUGH FIELD VISITATION AND CORRESPONDENCE WITH THE FLEET MANAGEMENT DIVISION.

PA DEPARTMENT OF TRANSPORTATION

FRONT PLOW HITCH ASSEMBLY

REVISIONS		FRONT PLOW HITCH ASSEMBLY	
NO.	DATE	BY	
1	04-27-15	GAW	
2	12-19-16	JJB	
3	08-02-18	KBD	

NO.	DATE	BY	SCALE	SHEET
1	04-27-15	GAW	N/A	EQN-50
2	12-19-16	JJB	N/A	EQN-50
3	08-02-18	KBD	N/A	EQN-50

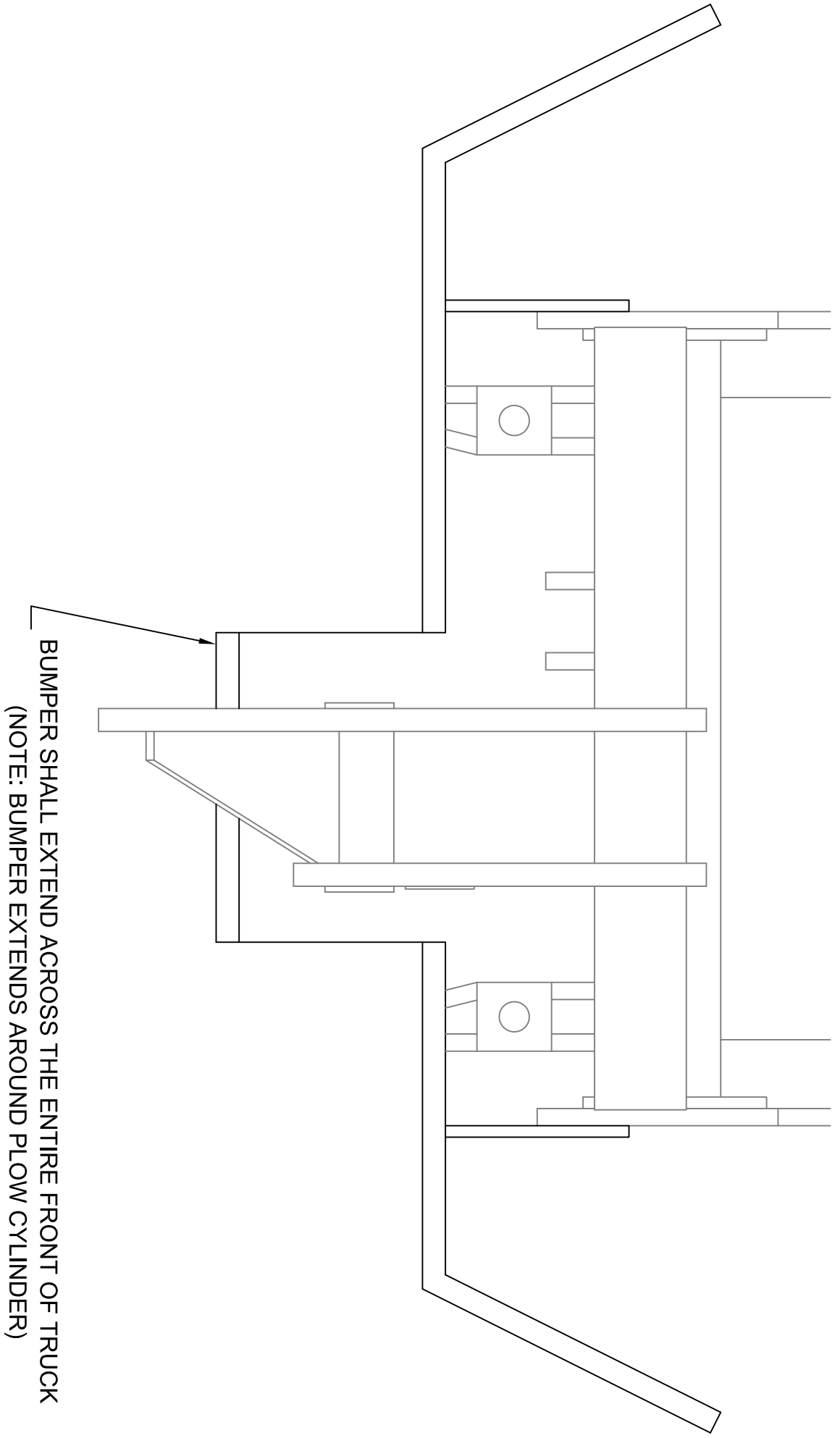

ADDITIONAL BUMPER SUPPORTS SHALL BE FABRICATED AND
 INSTALLED TO INSURE BUMPER RIGIDITY

BUMPER SHALL EXTEND ACROSS THE ENTIRE FRONT OF TRUCK
 (NOTE: BUMPER EXTENDS AROUND PLOW CYLINDER)

PA DEPARTMENT OF TRANSPORTATION

FRONT PLOW HITCH ASSEMBLY

REVISIONS			
NO.	DATE	BY	
1	04-27-15	GAW	
2	12-19-16	JJB	
3	08-02-18	KBD	

FRONT PLOW HITCH ASSEMBLY	SCALE	EQN-50
DRAWN BY	WHM	
DATE	11-05-95	
CHKD BY	WHM	SHEET 3 OF 4

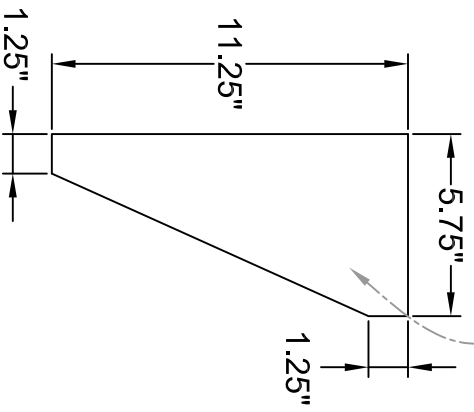
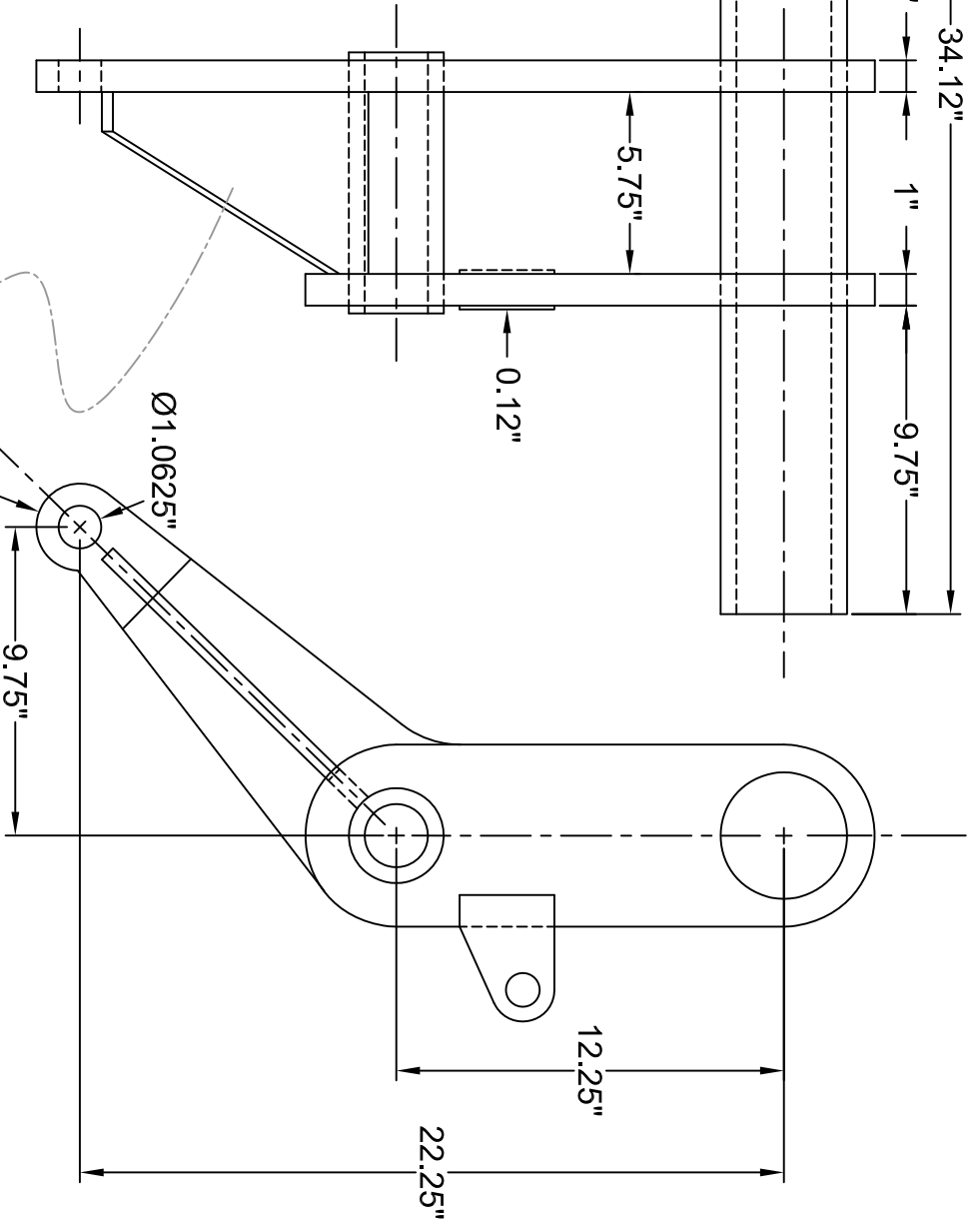
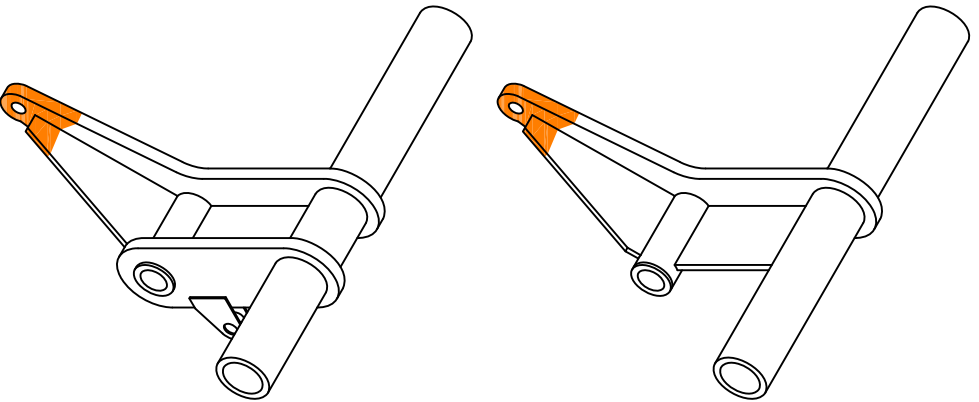
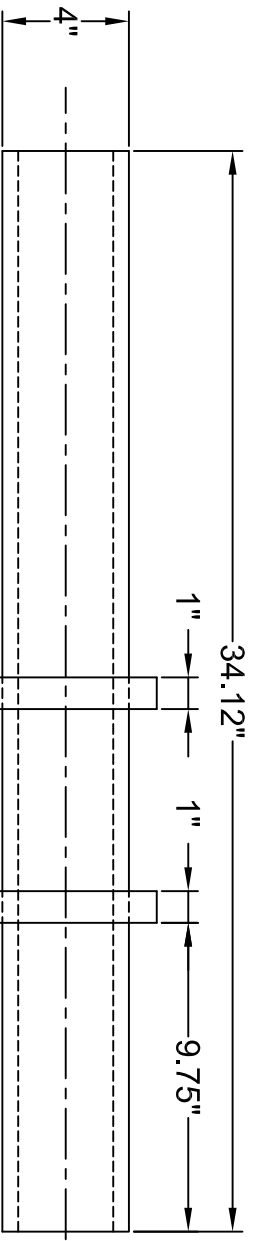

PAINT ENTIRE END FLUORESCENT ORANGE

PA DEPARTMENT OF TRANSPORTATION

REVISIONS

NO.	DATE	BY	SCALE
1	04-27-15	GAW	
2	12-19-16	JJB	
3	08-02-18	KBD	

FRONT PLOW HITCH ASSEMBLY

NO.	DATE	BY	SCALE
1	04-27-15	GAW	
2	12-19-16	JJB	
3	08-02-18	KBD	

FRONT POST REFERENCE SHEET 2

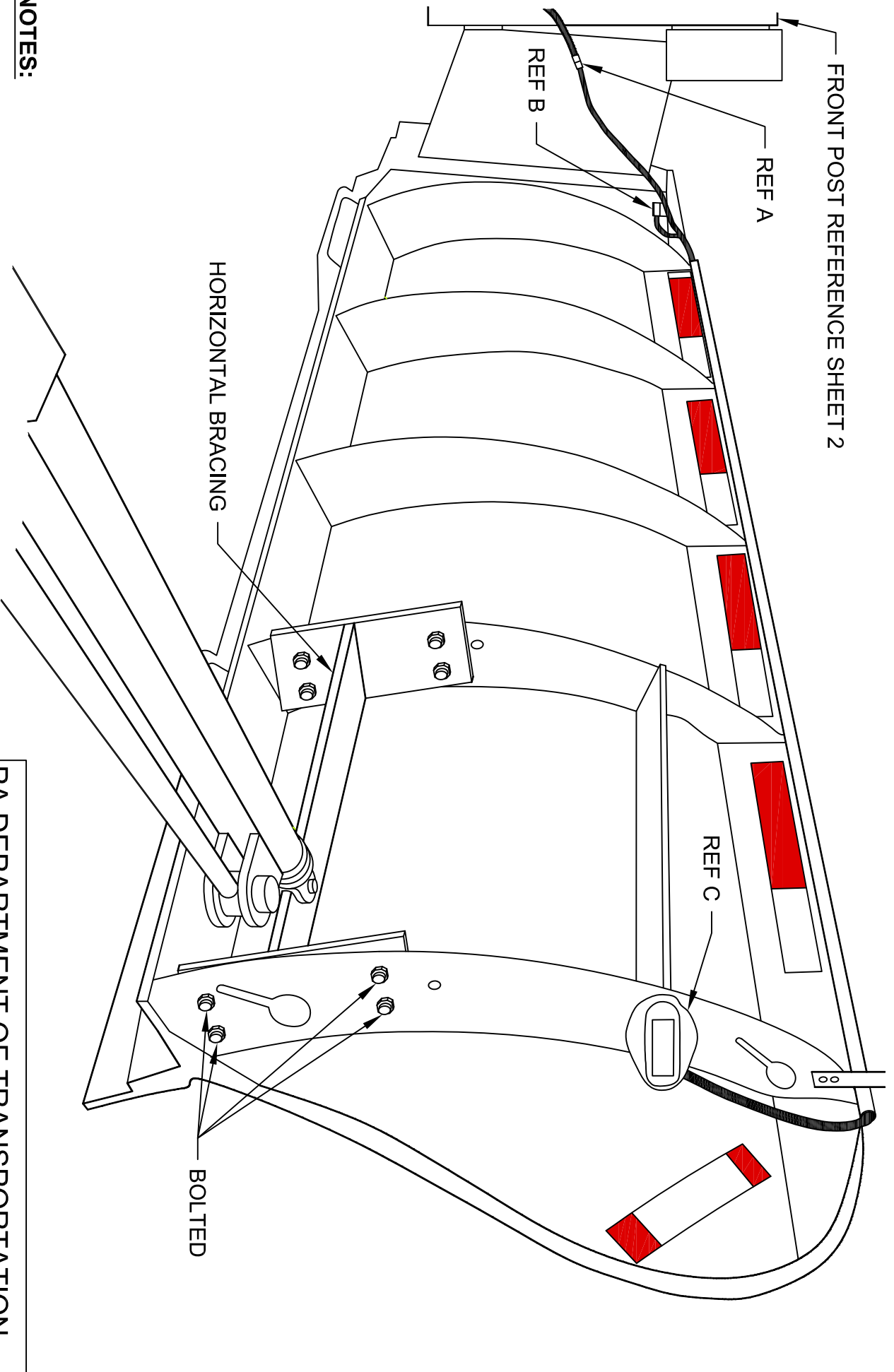

NOTES:

- A. ALL WIRING CONNECTIONS SHALL BE SEALED AND WEATHER TIGHT. 2 PRONG DEUTSCHE CONNECTOR, MALE FROM WING AND FEMALE FROM VEHICLE.
- B. MERCURY SWITCH, SHALL BE COMUS # CB08-90.
- C. WING LIGHT, SHALL BE WHELEN MODEL # PAWINGWR.

PA DEPARTMENT OF TRANSPORTATION

REVISIONS			DRAWN BY		
NO.	DATE	BY	DATE	SCALE	
1	12-19-16	JJB	07-15-15	N/A	EQN-60A
2	07-06-17	HMR			
3					

SNOWPLOW PATROL WING,
MOUNTING ARRANGEMENTS

DATE 07-15-15

CHG'D BY

SHEET 1 OF 2

NOTES:

- ALL PLOW GUIDES SHALL BE $\frac{3}{4}$ " x 36" GALVANIZED STEEL CABLE HIGH VISIBILITY ORANGE, 2 BOLTS
- A. TWO PLOW GUIDES SHALL BE MOUNTED ON THE FRONT POST. A MINIMUM OF THE TOP 3 INCHES OF THE STATIONARY GUIDE SHALL BE VISIBLE FROM CAB.
 - B. BOTH PLOW GUIDES ON THE MAST SHALL BE LEVEL WHEN PLOW IS IN THE LOWERED POSITION AND RESTING ON A LEVEL SURFACE.
 - C. ONE PLOW GUIDE SHALL BE MOUNTED ON REAR OF WING PLOW.

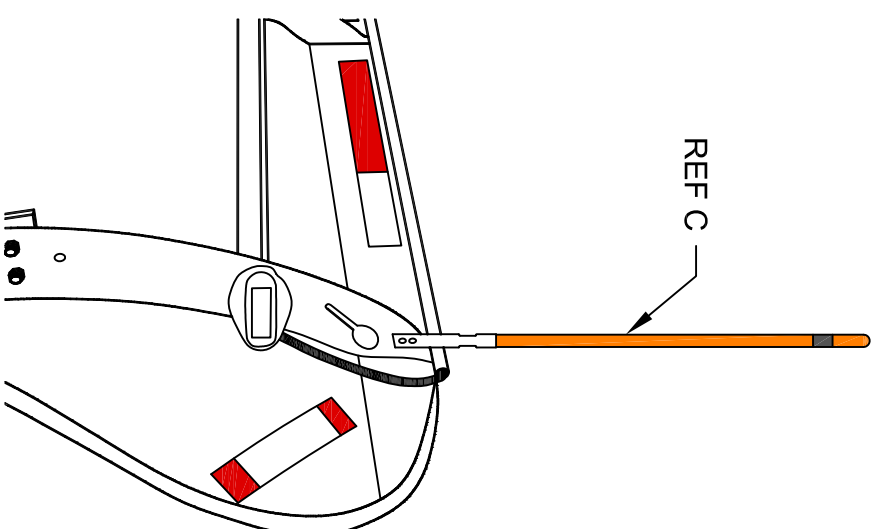
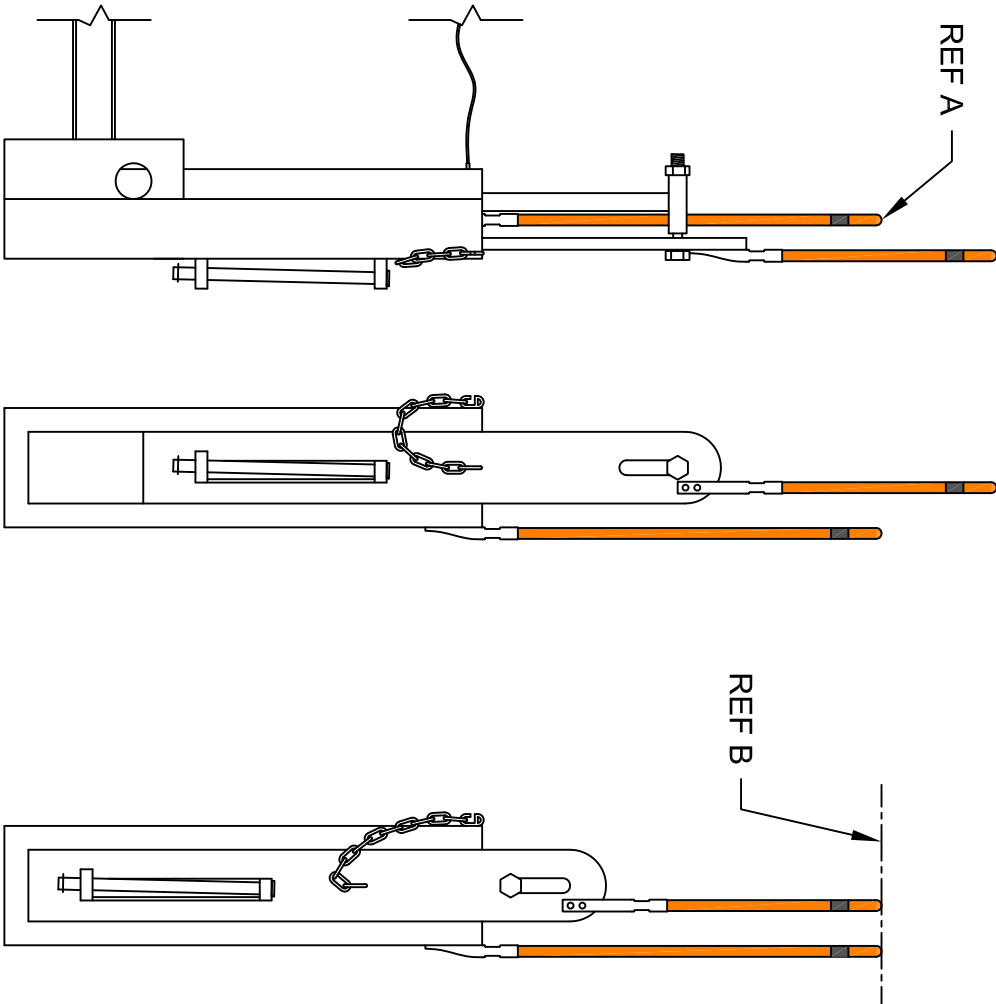

RAISED POSITION

LOWERED POSITION

PA DEPARTMENT OF TRANSPORTATION

REVISIONS		DRAWN BY		SCALE	
NO.	DATE	BY			
1	07-03-14	ACT	RAR	N/A	EQN-60A
2	12-19-16	JJB	RAR	N/A	EQN-60A
3	07-06-17	HMR	RAR	N/A	EQN-60A

**SNOWPLOW PATROL WING,
MOUNTING ARRANGEMENTS**

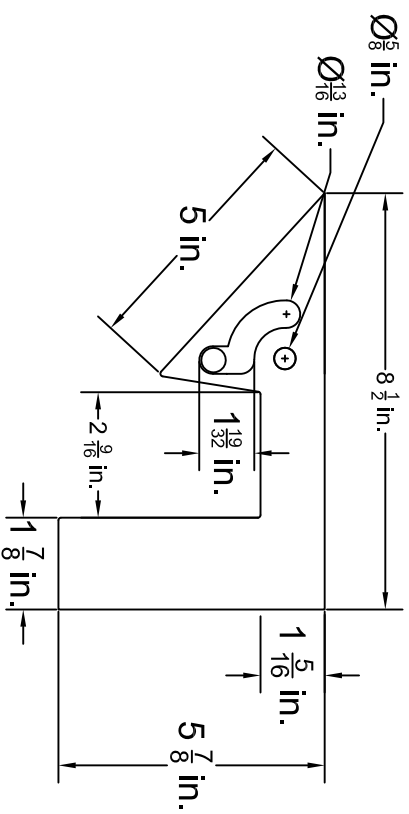

HINGE FRONT VIEW

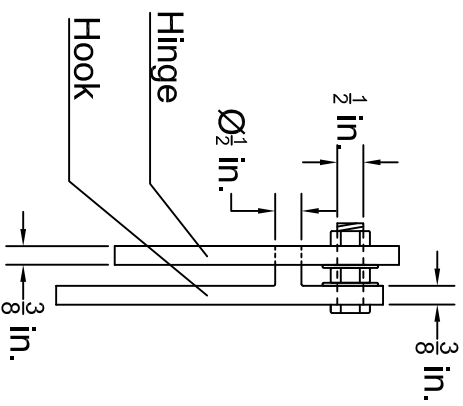

HOOK-HINGE SYSTEM
SIDE VIEW

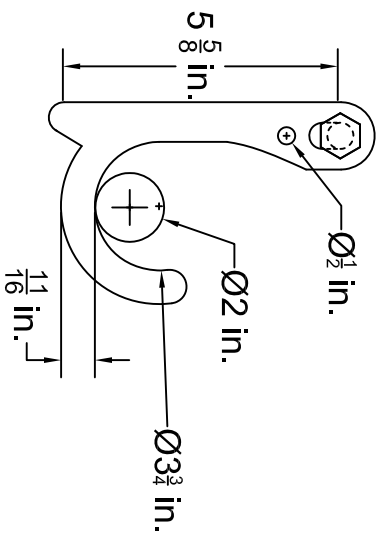

HOOK FRONT VIEW

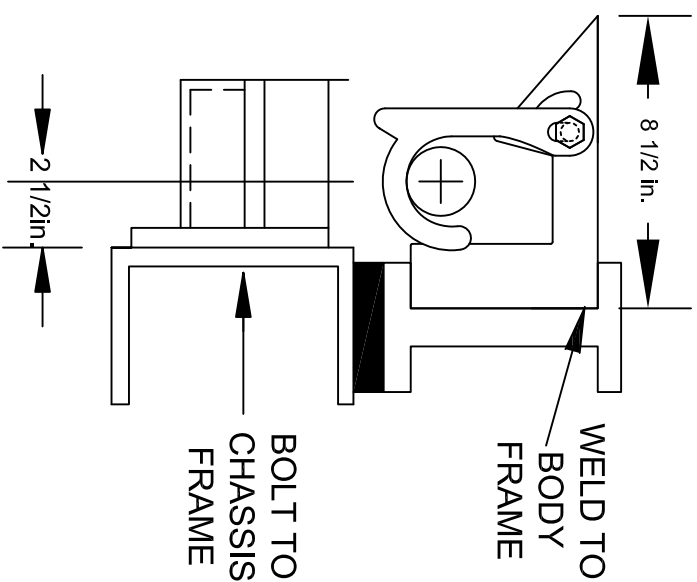

SYSTEM FRONT VIEW

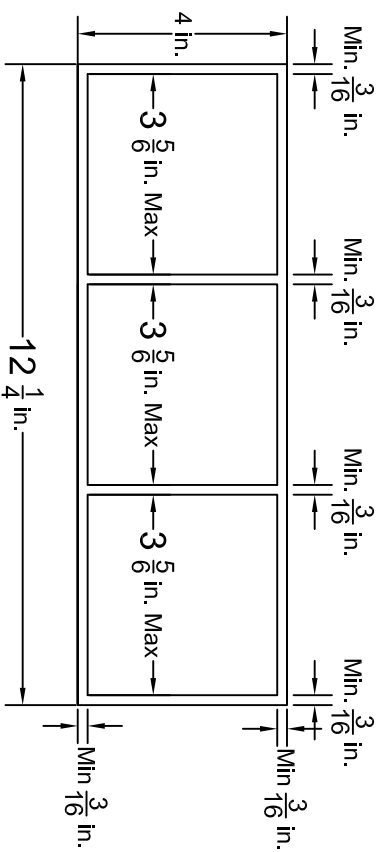

PROP STOP TOP VIEW

PA DEPARTMENT OF TRANSPORTATION

REVISIONS

NO.	DATE	BY	TOD	SCALE	EQN-62
1	7-13-09	TOD			
2	7-02-12	MJW		WHM	N/A
3	6-05-14	ACT		RED	SHEET 1 OF 2

BED PROP SYSTEM

BILL OF MATERIAL

DESCRIPTION

A.	PROP STOP- 12 1/4 in. X 4 in. MINIMUM 3/16 in. STEEL CONSTRUCTION
B.	HINGE- 6 in. X 6 in. MINIMUM 3/16 in. ALUMINUM CONSTRUCTION
C.	POST- 2in. X 27in. (SCH80) STEEL PIPE
D.	HOOK- 4 in. X 6 1/2 in. MINIMUM 3/16 in. STEEL CONSTRUCTION

NOTES

- TWO (2) SAFETY PROPS ARE REQUIRED PER VEHICLE.
- WHEN RELEASED FROM CRADLE, THE BED PROP SHALL BE FREE TO FREE-FALL. PROPS SHALL FALL INTO STOP "A" AS BED IS RAISED, UN-ASSISTED. HINGE "B" SHALL BE DESIGNED TO NOT ALLOW THE BED PROP TO TRAVEL PAST THE LAST POCKET ON THE PROP STOP "A".
- BOLTS SHALL BE GRADE 8 WITH GRADE 8 LOCK NUTS.
- ALL EDGES SHALL BE SMOOTH.

PA DEPARTMENT OF TRANSPORTATION

REVISIONS		BED PROP SYSTEM DUMP TRUCK	
NO.	DATE	BY	DRAWN BY
1	7-13-09	TOD	WHM
2	7-02-12	MJW	SCALE N/A
3	6-05-14	ACT	DATE 11-06-89

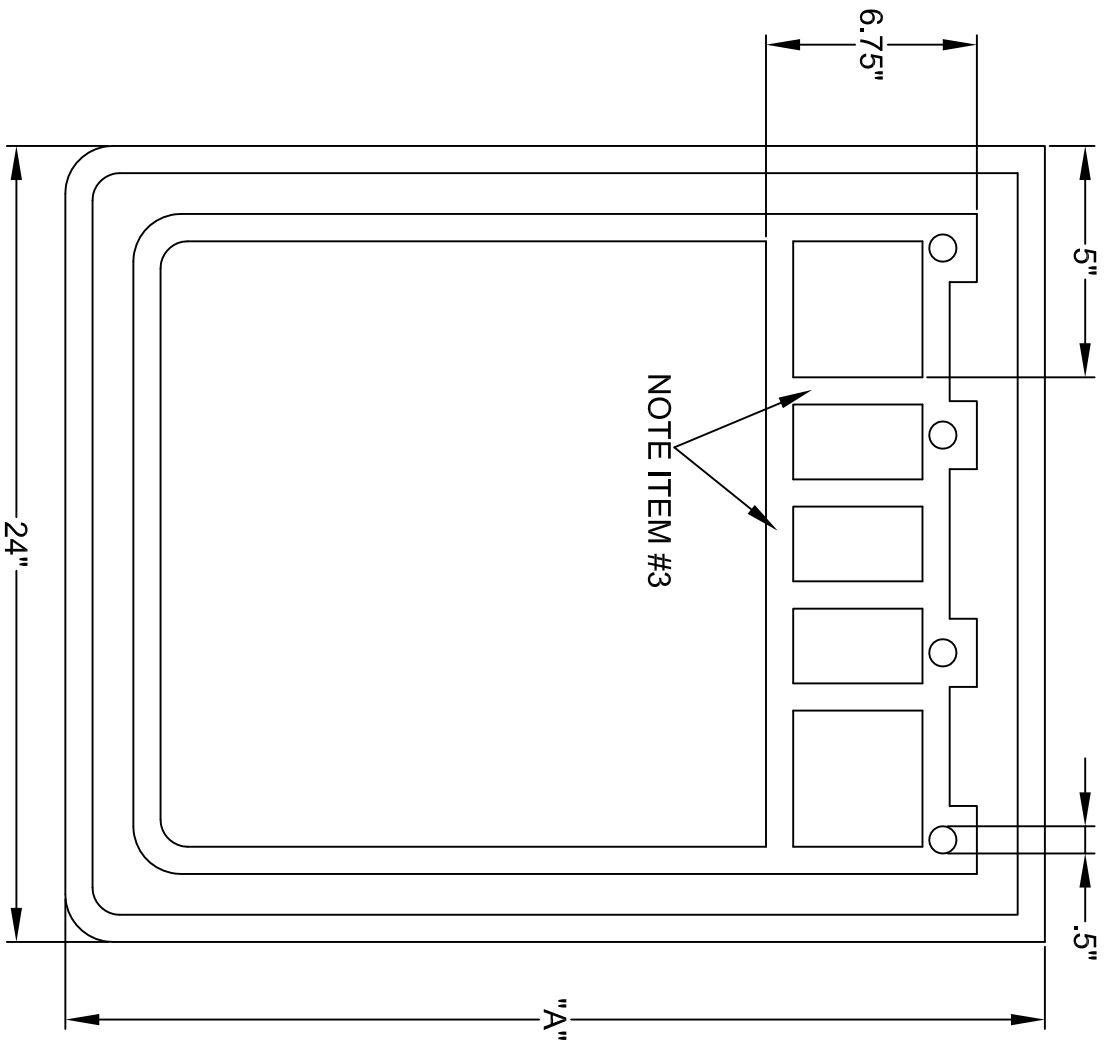

SAFETY

- NOTE:**
1. DIMENSION "A" DEPENDANT ON REQUISITION.
 2. MUD FLAPS SHALL BE "UNMARKED"

PA DEPARTMENT OF TRANSPORTATION

SPLASH GUARDS-RUBBER TRAILER & TRUCK

REVISIONS			DRAWN BY		
NO	DATE	BY	DATE	SCALE	
1	05-28-02	DWG	11-18-87	N/A	EQN-66
2	11-28-06	CJW			
3	07-20-09	TOD			

FENDERS AND FLAPS: VEHICLES SPECIFIED UNDER THIS SUBCHAPTER SHALL BE EQUIPPED WITH FENDERS WHICH PROVIDE AT LEAST AS MUCH COVERAGE OF THE WHEEL AS THE ORIGINAL EQUIPMENT. ALL WHEELS SHALL BE SUFFICIENTLY COVERED WITH FENDERS OR FLAPS SO AS TO PREVENT LOOSE OBJECTS, RAIN, SNOW, AND THE LIKE FROM BEING THROWN ABOUT IN A MANNER WHICH MAY INTERFERE WITH OTHER PERSONS USING THE HIGHWAY.

REAR WHEEL SHIELDS: VEHICLE SPECIFIED UNDER THIS SUBCHAPTER EXCEPT TRUCK-TRACTOR WHILE TOWING A TRAILER SHALL BE CONSTRUCTED OR EQUIPPED AS FAR AS TO BAR WATER OR OTHER ROAD SURFACES THROWN FROM REAR WHEELS OF SUCH VEHICLE OR COMBINATION AT TANGENTS EXCEEDING 22.5 DEGREES, MEASURED FROM ROAD SURFACE FROM PASSING IN STRAIGHT LINE TO THE REAR OF SUCH VEHICLE. SEE 75 PA C554533 (RELATING TO REAR WHEEL SHIELDS)

AREA 6.75"x24" ACROSS THE TOP IS ACCEPTABLE IN SOLID VIS RIBS PROVIDED IT MEASURES .225" IN THICKNESS

THE BODY OF SPLASH GUARD SHALL BE A MINIMUM OF .09375" THE TRIM AREA SHALL BE $\frac{3}{8}$ " MINIMUM THICKNESS. THE BODY AREA IS THE AREA WITHIN THE OUTSIDE DIMENSIONS OF 24"x36" TOLERANCES +/- .250" THE WEIGHT OF THE SPLASH GUARD SHALL BE 6LBS FOR 24"x30" AND 7.5lbs x 24" x 36" MINIMUM.

NOTE:

1. MATERIAL: MOLDED NATURAL OR SYNTHETIC BLACK TIRE CHORD IMPREGNATED RUBBER. OIL AND SALT RESISTANT.
2. ANTI-SAIL NOT ACCEPTABLE.
3. MANUFACTURERS STANDARD SIZE ACCEPTABLE IF ALL MINIMUM THICKNESS, DIMENSIONS, AND WEIGHT SPECIFICATIONS ARE MET.
4. AS PER PA VEHICLES EQUIPMENT AND INSPECTION REGULATIONS, SECTION 175-108.
5. DIMENSION "A" WILL BE 30" OF 36" AS NECESSARY, WHEN INSTALLED TO MEET PA MOTOR VEHICLE CODE OR AS SPECIFIED ON THE CONTRACT.
6. MUD FLAPS SHALL BE "UNMARKED"

PA DEPARTMENT OF TRANSPORTATION

REVISIONS		DRAWN BY		SCALE	
NO	DATE	BY			
1	05-28-02	DWG	S.T.	N/A	EQN-66
2	11-28-06	CJW			
3	07-20-09	TOD	DATE 11-18-87	CHG'D BY RED	SHEET 2 OF 2

SPLASH GUARDS-RUBBER TRAILER & TRUCK

JAMES KING & CO.
 TRIANGLE PART #1005
 OR APPROVED EQUAL

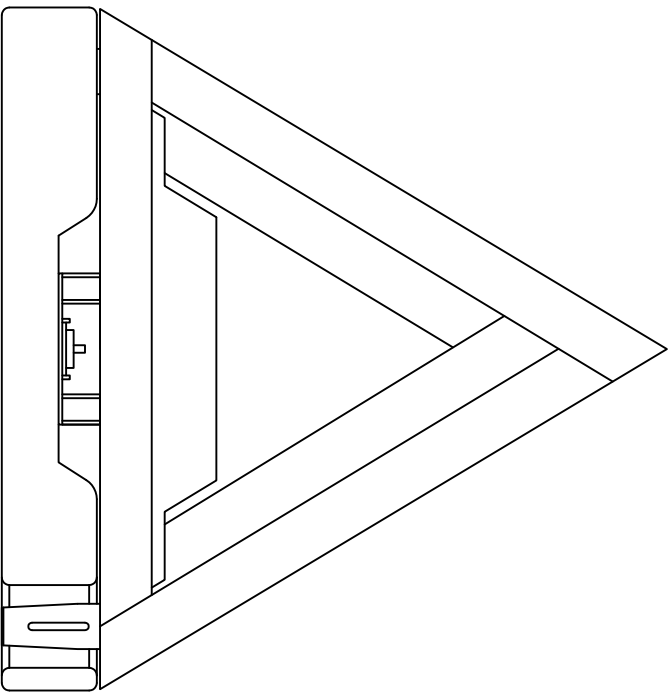

PA DEPARTMENT OF TRANSPORTATION

REVISIONS			DRAWN BY			SCALE		
NO.	DATE	BY	DATE	CHK'D BY	SHEET	TRIANGLE STORAGE BOX AND BRACKET		
1	05-31-07	KNH		WHM	N/A	EQN-66A		
2	07-20-09	TOD		RED		SHEET 1 OF 1		
3	07-13-17	HMR						

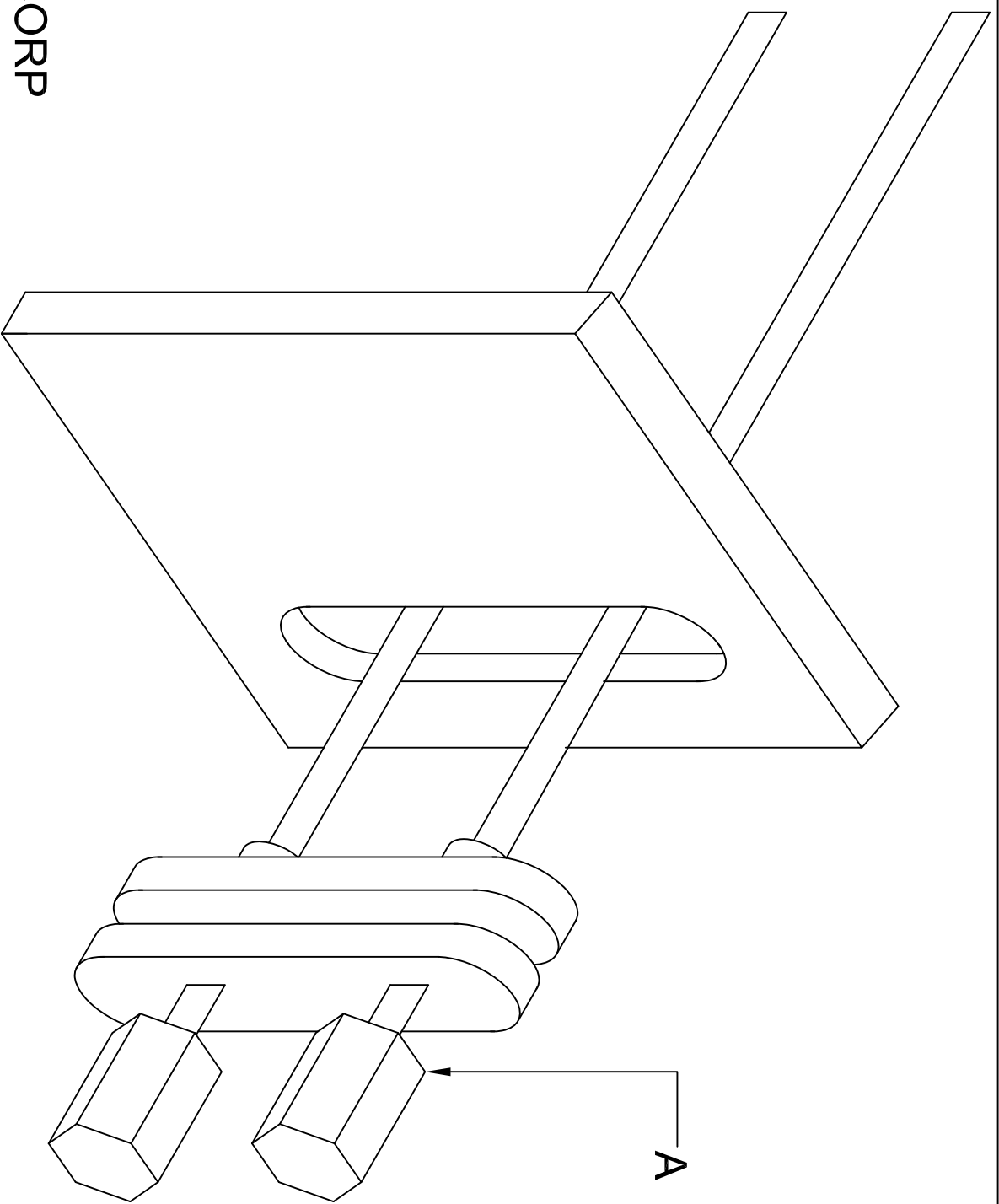

A.
 PANA PACIFIC CORP
 541 DIVISION STREET
 CAMPBELL, CALIFORNIA 95008
 408-374-7900

PART #531 277 C1

PA DEPARTMENT OF TRANSPORTATION			C.B. RADIO CONNECTIONS		
REVISIONS					
NO.	DATE	BY			
1	08-15-90	WHM			
2	07-02-97	DLW			
3	10-27-06	CJW			
		DRAWN BY	WHM	SCALE	EQN-78
		DATE	08-15-90	CHECKED BY	RED
		SHEET 1 OF 1			

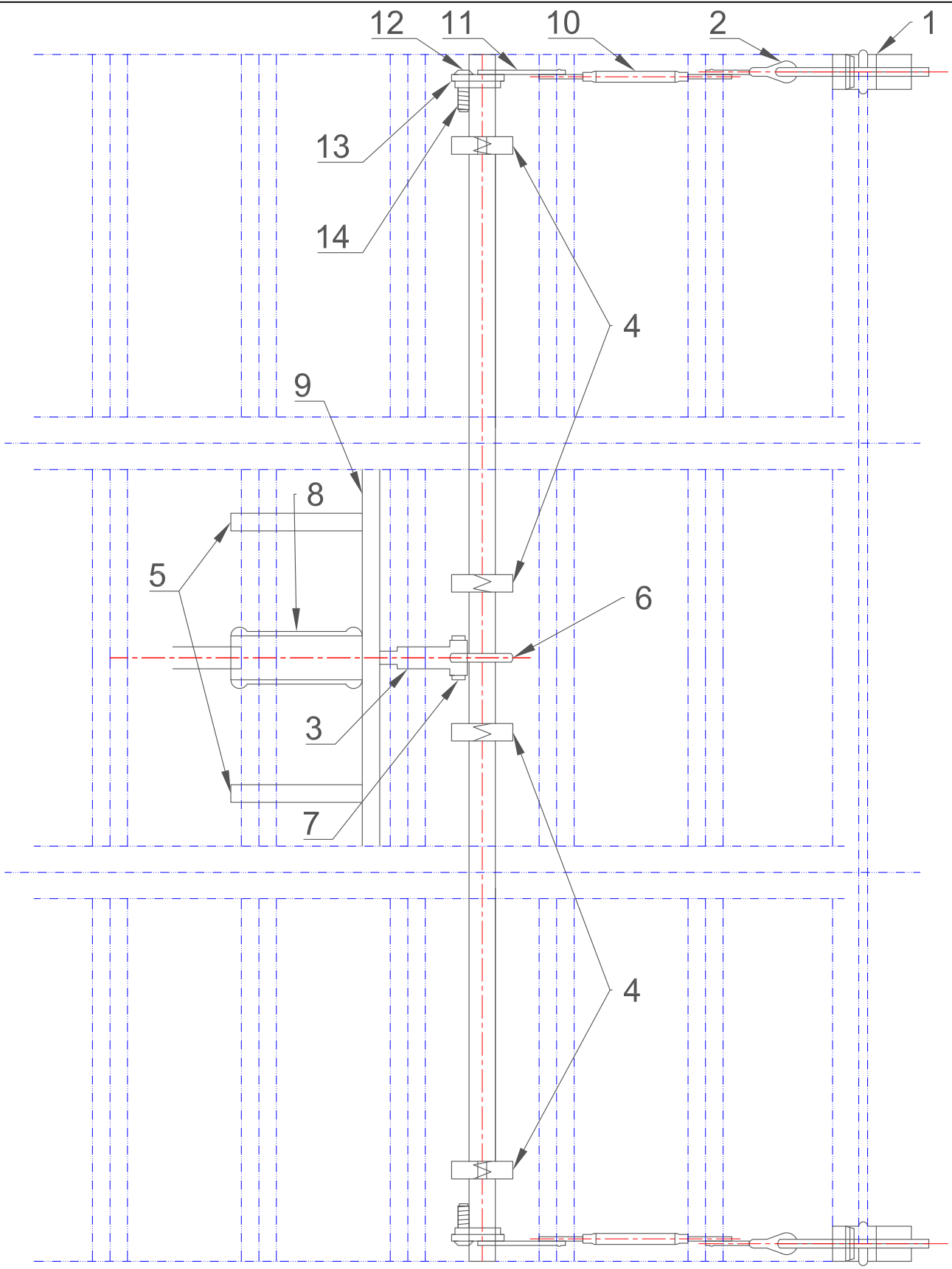

PA DEPARTMENT OF TRANSPORTATION

REVISIONS

NO.	DATE	BY
1	10-06-97	DLW
2	06-03-02	DWG
3	07-13-17	JFM

AIR TAILGATE, HARDWARE
(DUMP TRUCK)

DRAWN BY	WHM	SCALE	3:1	EQN-78A
DATE	08-04-95	CHK'D BY	RED	SHEET 1 OF 3

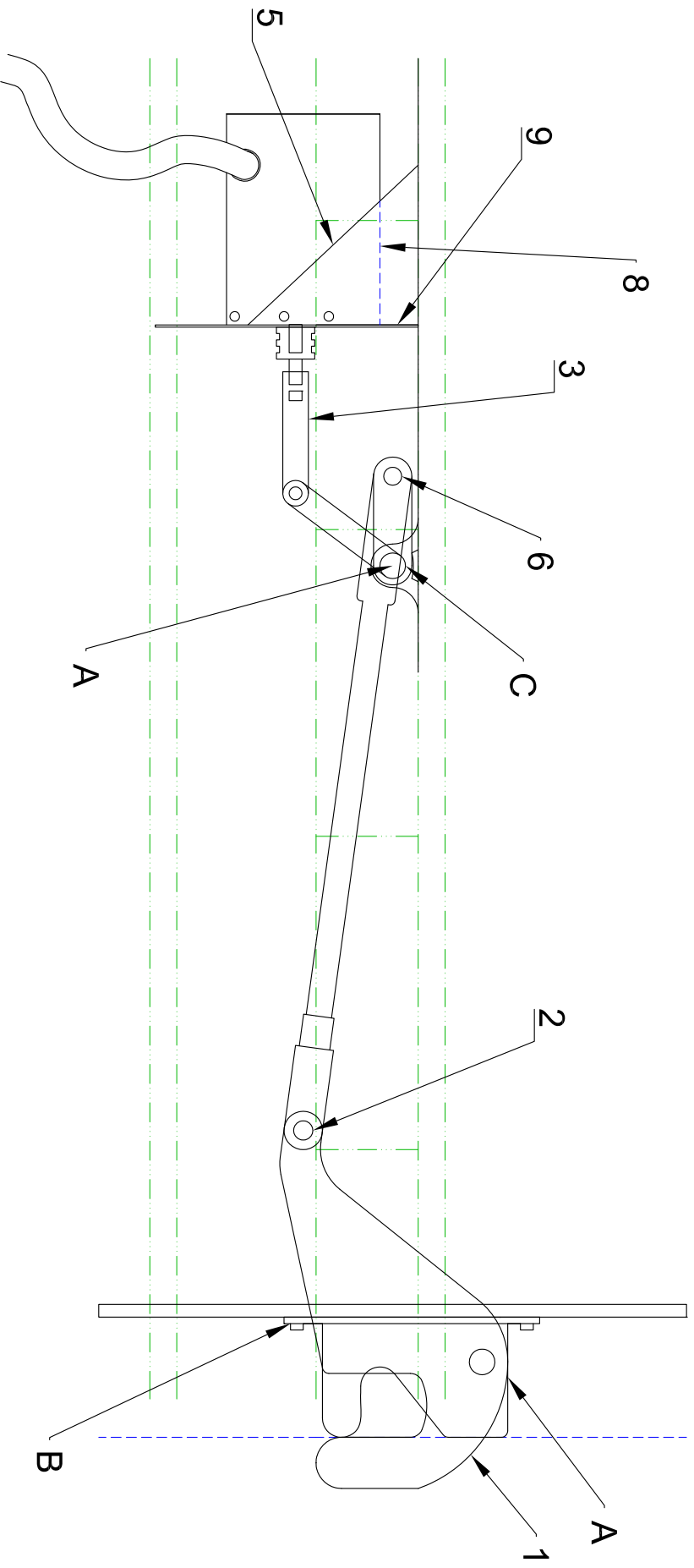

AIR HOSE SHALL BE OF PROPER LENGTH AND CLAMPED SUFFICIENTLY TO ELIMINATE CHAFING. AIR LINE SHALL BE COVERED IN PLASTIC LOOM WHERE IT EXTENDS THROUGH THE BULKHEAD FITTING/S.

NOTES: A - DRILLED AND TAPED WITH ZERK FITTING OR NYLON BUSHING BUYERS TEL. (440) 974-8888

B - TAILGATE LATCHES MUST BE BOLTED IN, WELDED NOT ACCEPTABLE.

C - MUST BE ABLE TO BE ADJUSTED OVER CENTER INTO A LOCKING POSITION.

PA DEPARTMENT OF TRANSPORTATION

REVISIONS			AIR TAILGATE, HARDWARE (DUMP TRUCK)		
NO.	DATE	BY	DATE	SCALE	
1	06-03-02	DWG			
2	05-30-13	JFM	08-04-95	2:1	EQN-78A
3	07-13-17	HMR			

BILL OF MATERIAL (PARTIAL LIST)

<u>ITEM</u>	<u>QTY</u>	<u>DESCRIPTION</u>
1	2	HEAVY HARDWARE ASSEMBLY (LATCHING)
2	2	CLEVIS (BUYERS #2708-6C/ .50 in.)
3	1	AIR CYLINDER CLEVIS
4	4	BEARING BLOCK ASSEMBLY (WITH ZERK FITTING)
5	2	GUSSET
6	1	CAM / LINKAGE
7	1	YOKE PIN (BUYERS #B2708-1/2-8A/ .75in.)
8	1	AIR CYLINDER (AIR OVER SPRING OR AIR OVER AIR)
9	1	CYLINDER SUPPORT PLATE
10	2	TURNBUCKLE .625 in. x 6 in.
11	2	REAR LENGTH BAR
12	2	BOLT .625 IN. x 2 in.
13	2	FLAT WASHER .625 in.
14	3	NUT .625 in. NYLON LOCK

PA DEPARTMENT OF TRANSPORTATION

REVISIONS			AIR TAILGATE, HARDWARE (DUMP TRUCK)		
NO.	DATE	BY	DRAWN BY	SCALE	
1	10-06-97	DLW			
2	06-03-02	DWG	WHM	N/A	EQN-78A
3	7-13-17	JFM	08-04-95	RED	SHEET 3 OF 3

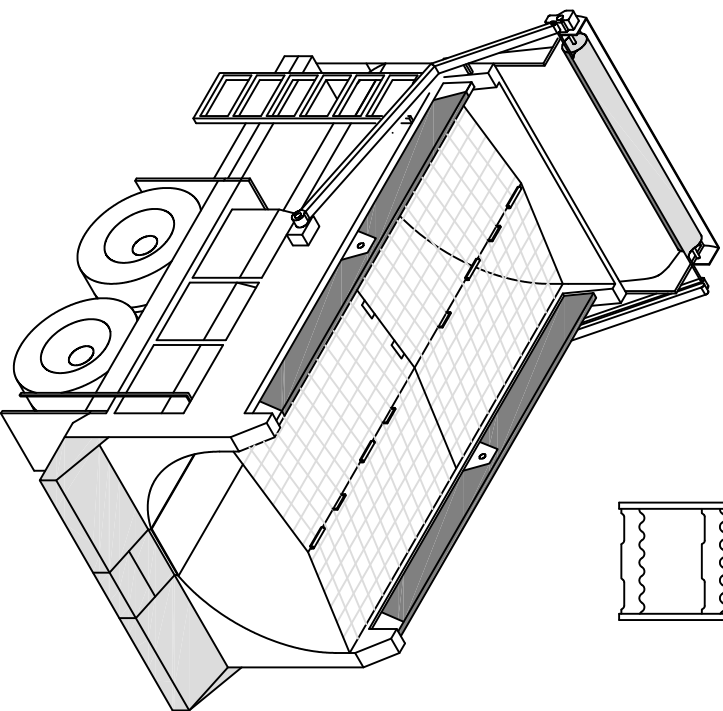
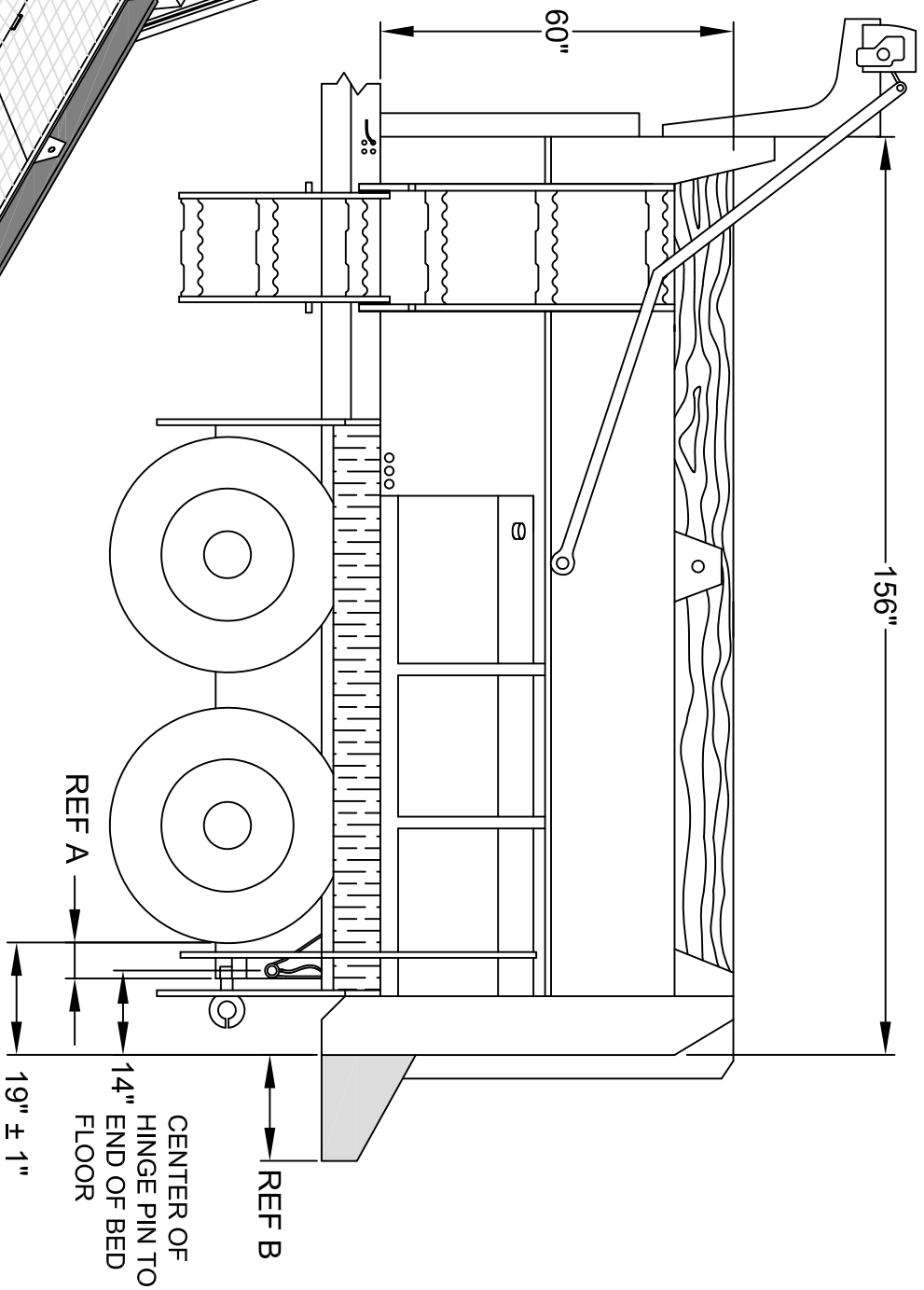

SHOWN WITH TAILGATE REMOVED

- NOTES:**
- A. SHALL BE NO MORE THEN 5" ± 1" MEASURED FROM REAR OF BACK TIRE TO END OF FRAME RAIL.
 - B. IF REAR AUGER MOTOR ASSEMBLY IS UTILIZED, REAR APRON MAY NOT EXCEED 15 INCHES.

PA DEPARTMENT OF TRANSPORTATION

AUGER FLOOR BODY

REVISIONS			
NO.	DATE	BY	
1	12-20-16	JJB	
2	08-06-19	KBD	
3			

DRAWN BY	JJB	SCALE	N/A	EQN-79AF
DATE	07-17-15	CHKD BY		SHEET 1 OF 7

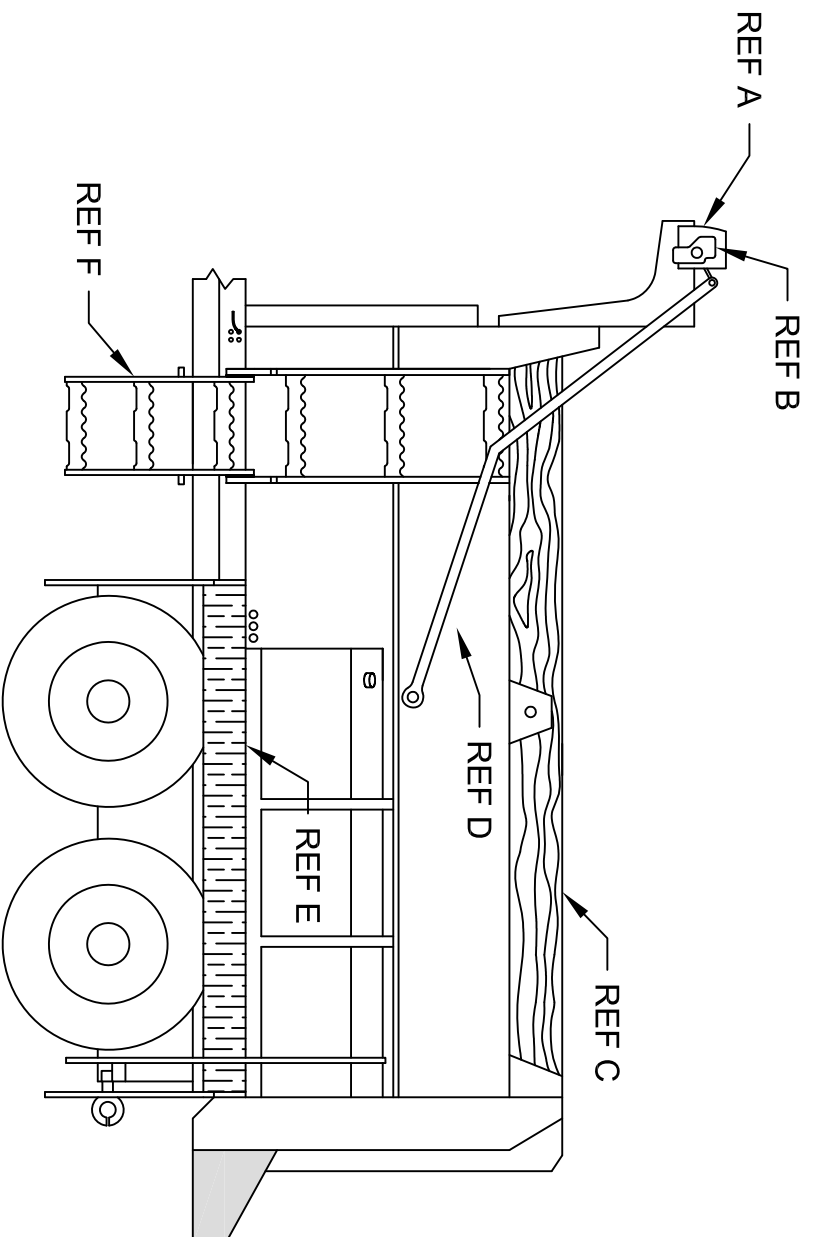

- NOTES:**
- A. TARP ASSEMBLY WIND GUARD. TO REDUCE DRAG AND EXTEND TARP LIFE.
 - B. TARP ASSEMBLY MOTOR. TO ALLOW USE OF TARP ASSEMBLY.
 - C. 2"X6" ROUGH OAK.
 - D. TARP ASSEMBLY
 - E. SPRAY SUPPRESSION. SHALL BE PLACED ON BOTH DRIVER AND PASSENGER SIDE.
 - F. FOLD UP LADDER.

PA DEPARTMENT OF TRANSPORTATION

AUGER FLOOR BODY

REVISIONS			DRAWN BY			SCALE		
NO.	DATE	BY	JJB	N/A	EQN-79AF			
1	08-06-19	KBD						
2								
3								

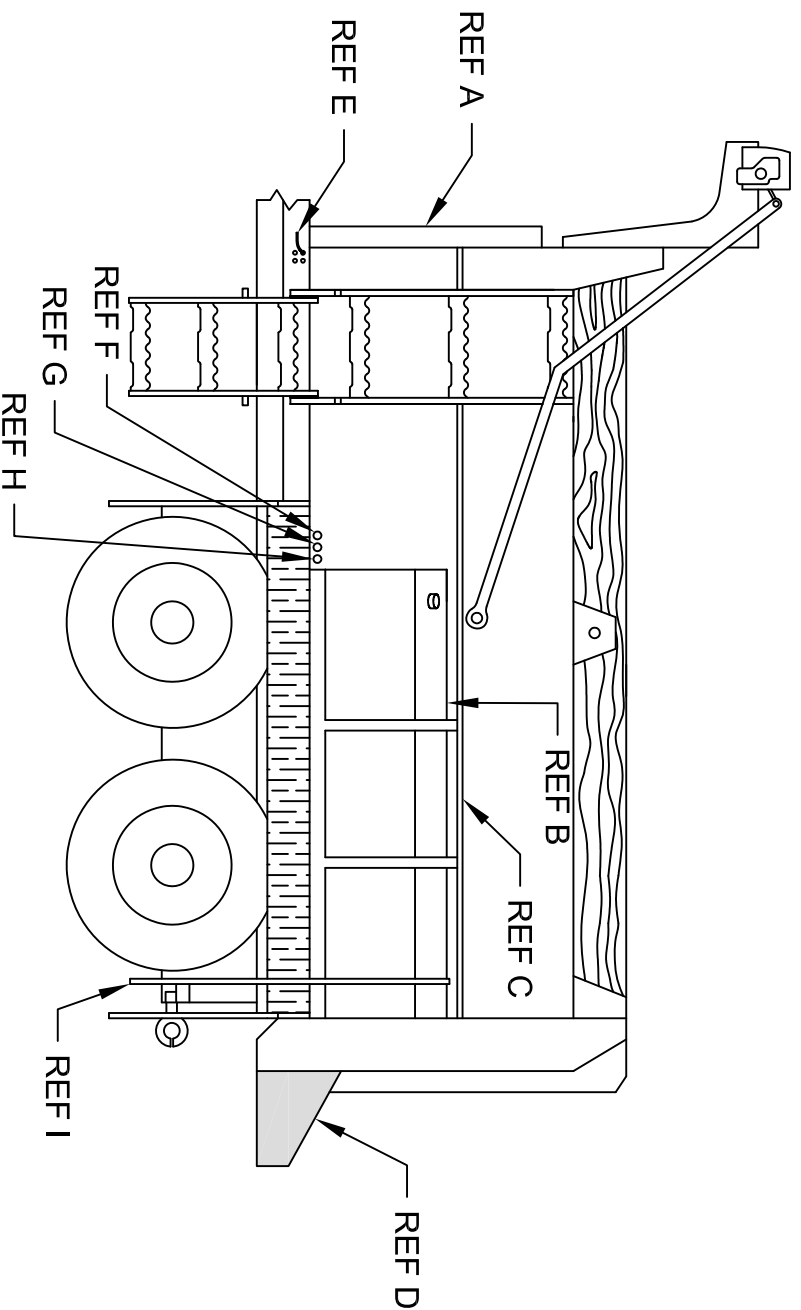

NOTES:

- A. HYDRAULIC CYLINDER. FOR USE OF DUMP MECHANISM.
- B. PRE-WET TANK. LOCATION SHALL BE DETERMINED AT PRE-BUILD.
- C. TARP RAIL. TO PROVIDE A MECHANISM TO TIE DOWN TARPS. SHALL BE 1/2 INCH ROUND STOCK MINIMUM.
- D. OPTIONAL REAR-LOCATED AUGER MOTOR ASSEMBLY.
- E. GROUND WIRE LOCATED ON BACK OF HINGE PIN.
- F. FILL/DRAIN.
- G. FLUSH KIT.
- H. CROSS OVER PIPE.
- I. PRE-WET TANK OVERFLOW. SHALL BE MOUNTED TO ALLOW OVERFLOW TO DRAIN BELOW THE FRAME RAIL.

PA DEPARTMENT OF TRANSPORTATION

AUGER FLOOR BODY

REVISIONS			
NO.	DATE	BY	
1	08-06-19	KBD	
2			
3			

DRAWN BY	JJB	SCALE	N/A	EQN-79AF
DATE	07-17-15	CHKD BY		SHEET 3 OF 7

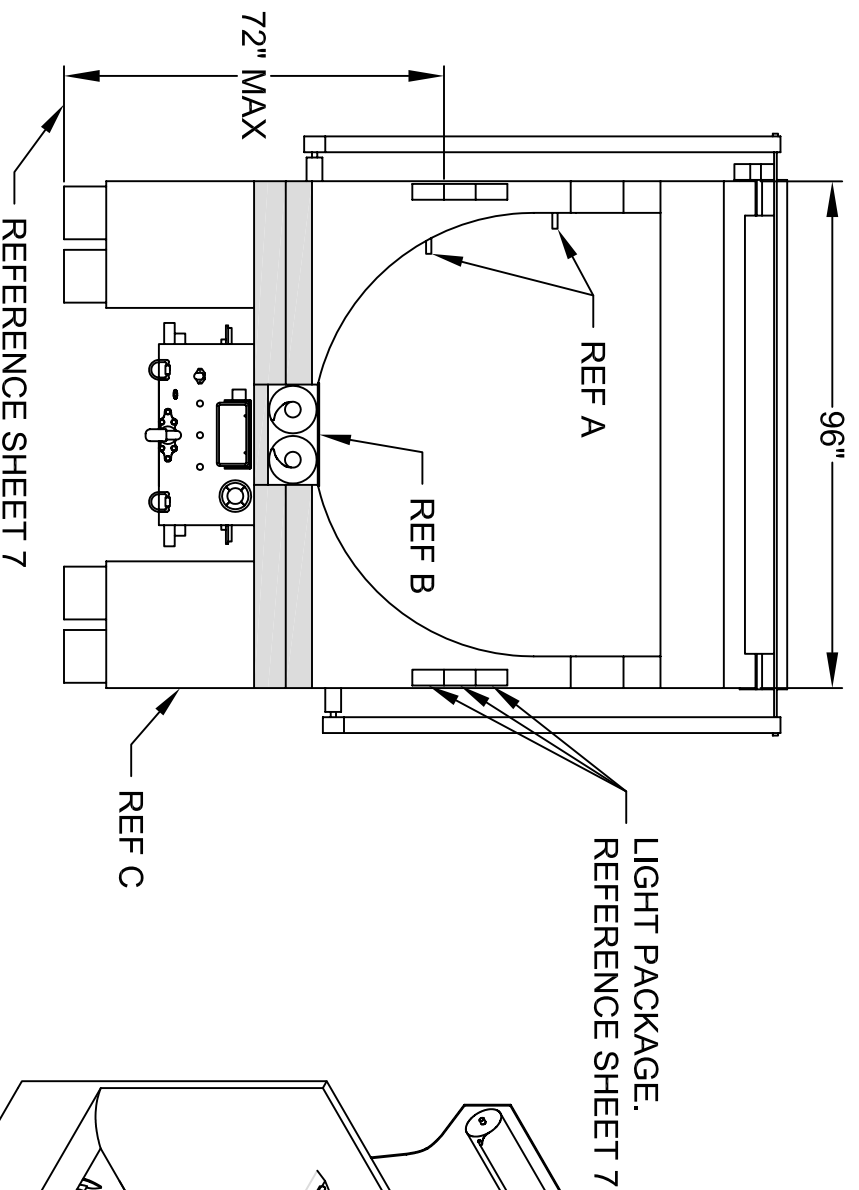

SHOWN WITH
TAILGATE REMOVED

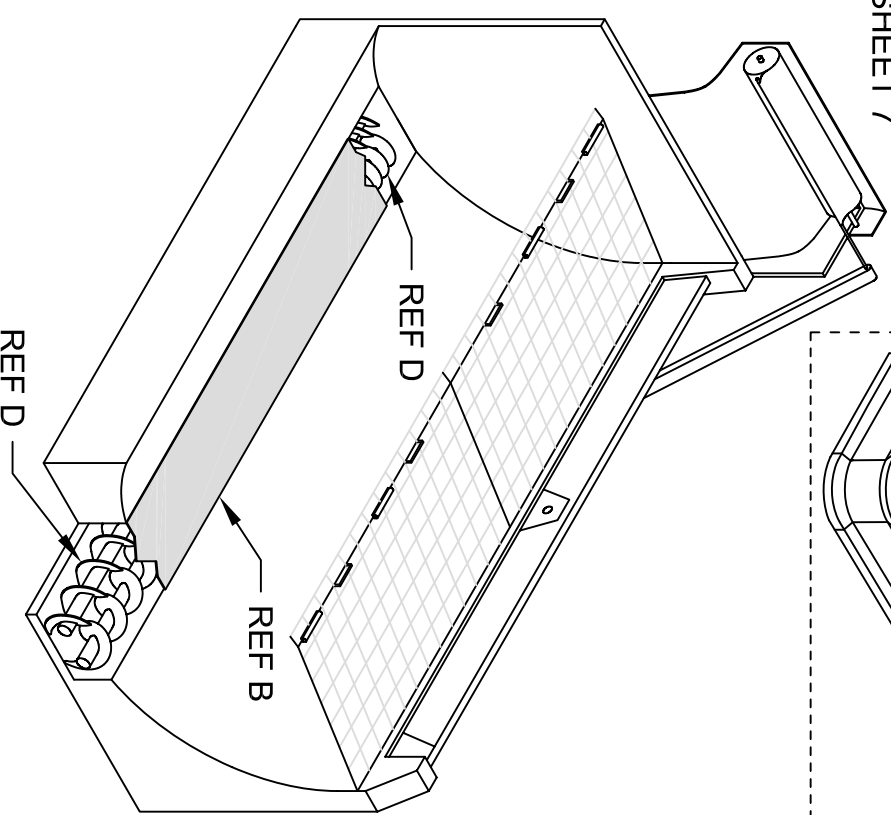
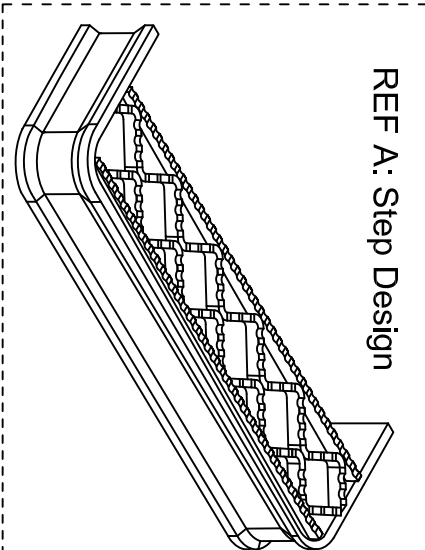

- NOTES:**
- A. TWO STEPS ON BED WALL. SHALL BE SERRATED. THE OUTER EDGE MUST BE SERRATED IN LIEU OF PLAIN.
 - B. REMOVABLE METAL PLATE. SHALL COMPLETELY COVER AUGERS WHEN INSTALLED. TO ALLOW BODY TO FUNCTION AS NORMAL DUMP BODY WITHOUT INTERFERENCE OF AUGERS.
 - C. MUDFLAPS. SHALL BE PLAIN.
 - D. DUAL AUGERS. SHALL BE FLOOR MOUNTED AND TAPERED.

PA DEPARTMENT OF TRANSPORTATION

AUGER FLOOR BODY

REVISIONS			
NO.	DATE	BY	
1	08-06-19	KBD	
2			
3			

DRAWN BY	JJB	SCALE	N/A	EQN-79AF
DATE	07-17-15	CHKD BY		SHEET 4 OF 7

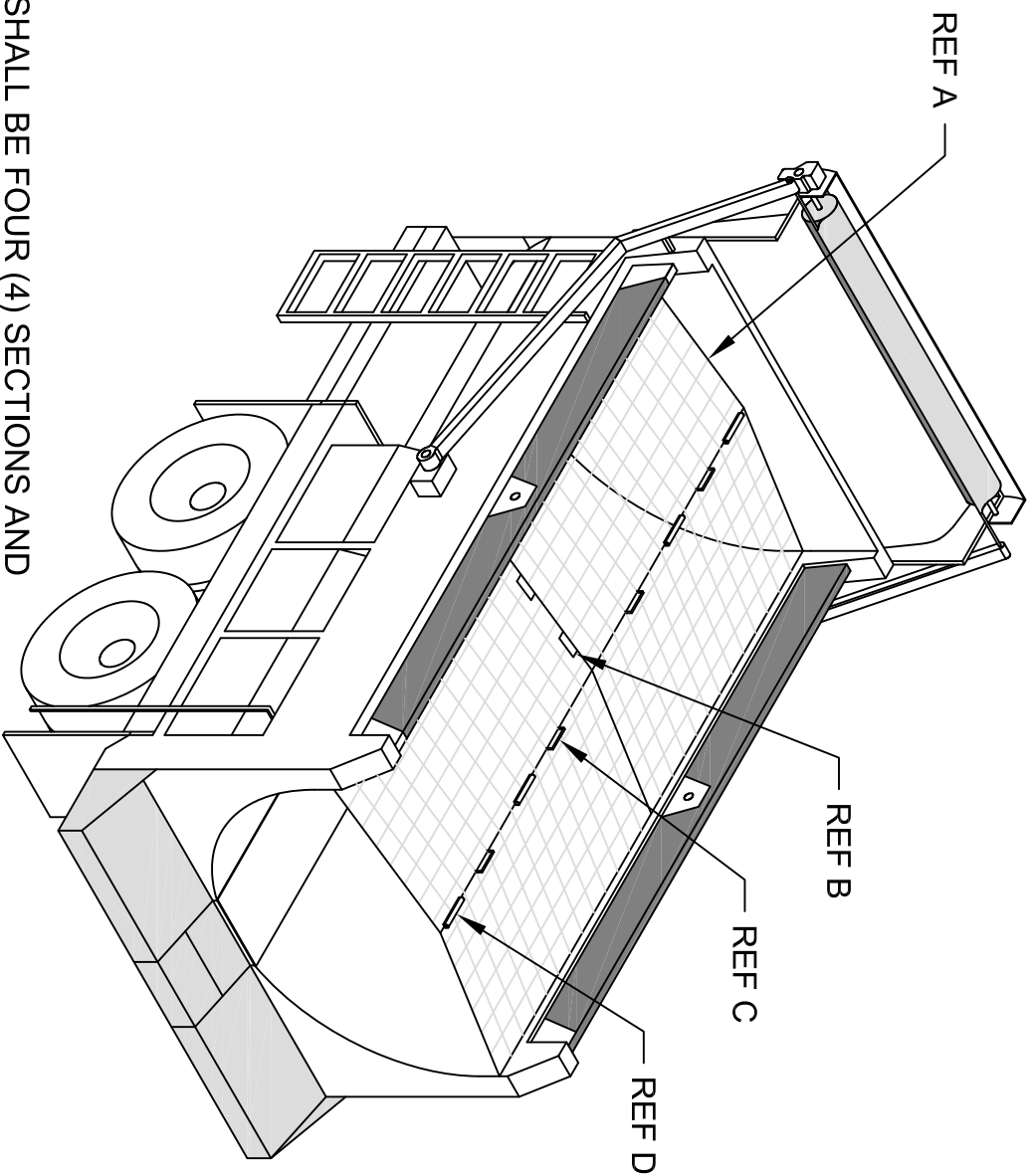

- NOTES:**
- A. SAFETY GRATE. SHALL BE FOUR (4) SECTIONS AND HINGED TO PROHIBIT BED ENTRY WHEN AUGERS ARE IN USE. SHALL HAVE SAFETY MECHANISM TO STOP AUGERS WHEN GRATE IS OPENED.
 - B. SAFETY FLAP. SHALL BE PLACED ON FRONT MOST SECTION OF GRATE ON DRIVER SIDE TO PROHIBIT LIFTING OF BACK MOST SECTION.
 - C. REMOVING BAR. SHALL HAVE MECHANISM MOUNTED TO TOP OF GRATES TO ALLOW SAFE REMOVAL OF GRATES.
 - D. HINGE. SHALL BE HAVE HINGED MECHANISM MOUNTED TO TOP OF GRATES TO ALLOW LIFTING OF DRIVER SIDE GRATES.

PA DEPARTMENT OF TRANSPORTATION

AUGER FLOOR BODY

REVISIONS			DRAWN BY			SCALE		
NO.	DATE	BY	JJB	N/A	EQN-79AF			
1	08-06-19	KBD						
2								
3								

SHOVEL HOLDER

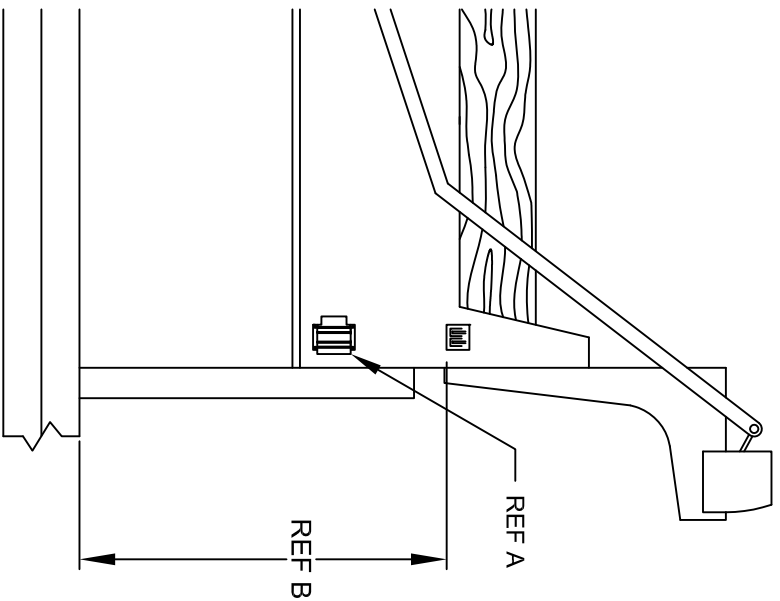

- NOTES:**
- A. SHOVEL HOLDER, BUYERS PART #SH675SS, LOCATION SHALL BE DETERMINED AT PREBUILD.
 - B. SHOVEL HOLDER AND HANGER SHALL ACCOMMODATE UP TO A SHOVEL WITH A 51 INCH LENGTH HANDLE WITHOUT INTERFERING WITH ANY OTHER COMPONENTS OF THE TRUCK.

TAILGATE WINGS LEFT AND RIGHT INSIDE

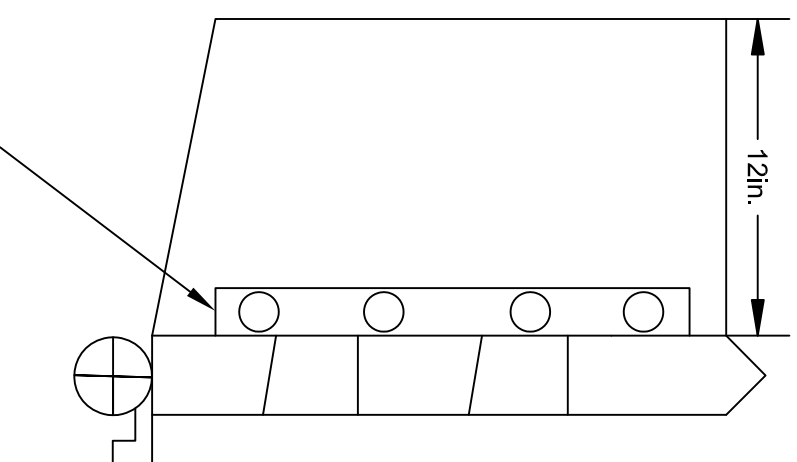

2in. ANGLE ALUMINUM WITH 4 SLOTTED HOLES
.375in. X 1in. ON OUTER SIDE. .375in. STAINLESS
STEEL COUNTERSUNK MACHINE SCREWS
WITH STAINLESS STEEL NUTS AND FLAT
WASHERS SHALL BE USED.

PA DEPARTMENT OF TRANSPORTATION

REVISIONS

NO.	DATE	BY	SCALE	CHRG BY
1	04-27-15	GAW		
2	07-17-15	JJB	N/A	
3	08-06-19	KBD		

AUGER FLOOR BODY

SM		EQN-79AF
08-11-93		SHEET 6 OF 7

TRUCK REAR MODULE

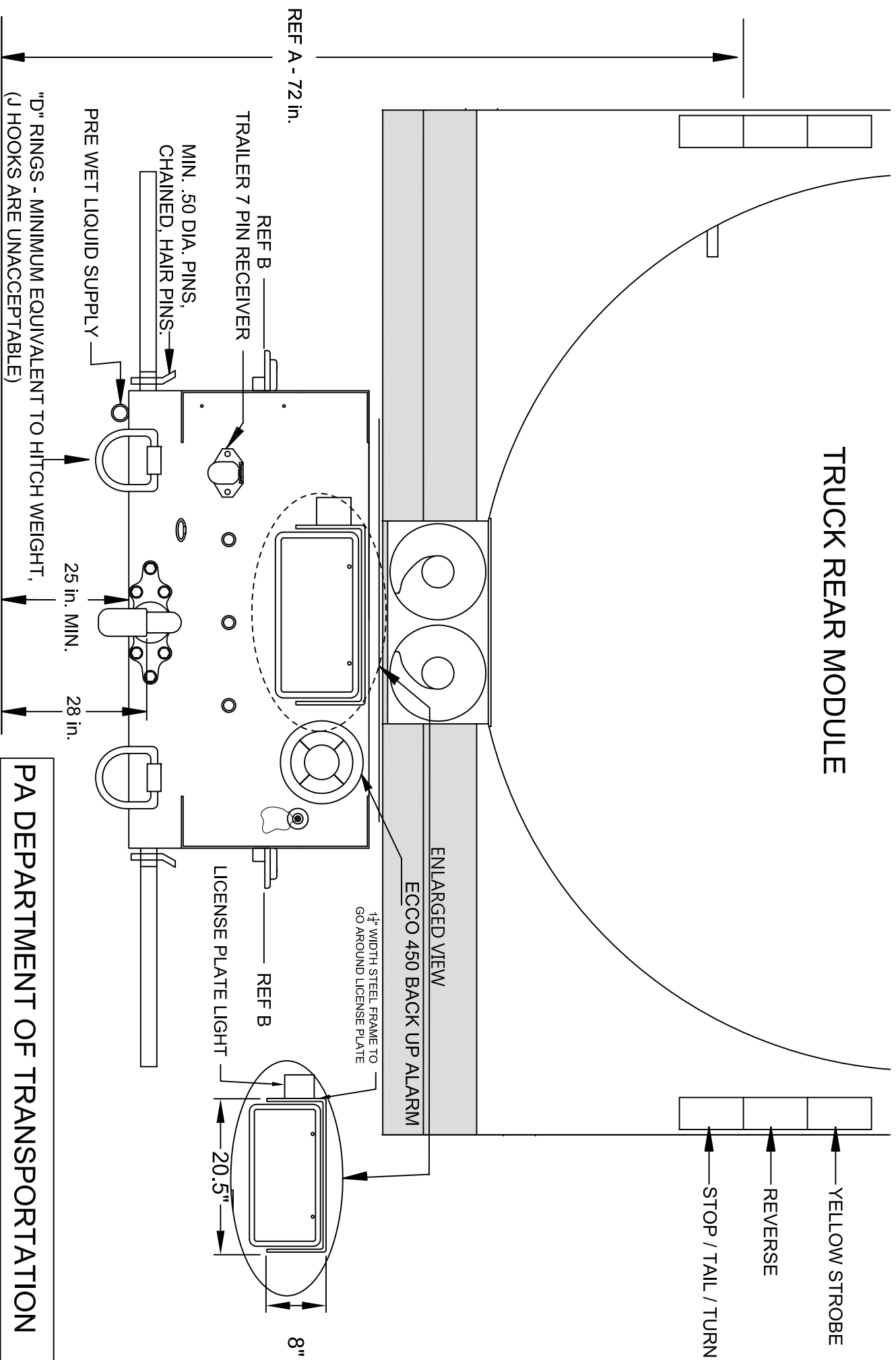

- A. HEIGHT OF LIGHTS SHALL NOT EXCEED 72" FROM TOP OF STOP / TURN / TAIL LIGHT TO GROUND, BODY UNLOADED.
- B. AIR BRAKE

PA DEPARTMENT OF TRANSPORTATION

REVISIONS

NO.	DATE	BY	DRAWN BY	SCALE	EQN-79AF
1	07-17-15	JJB	WHM	N/A	EQN-79AF
2	05-23-16	JJB	WHM	N/A	EQN-79AF
3	08-06-19	KBD	WHM	N/A	EQN-79AF

AUGER FLOOR BODY

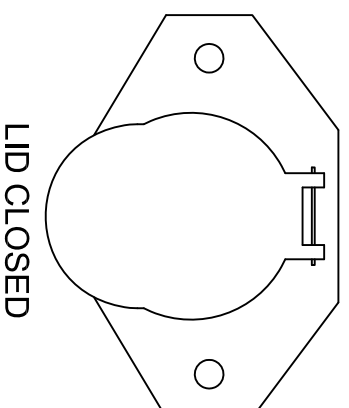
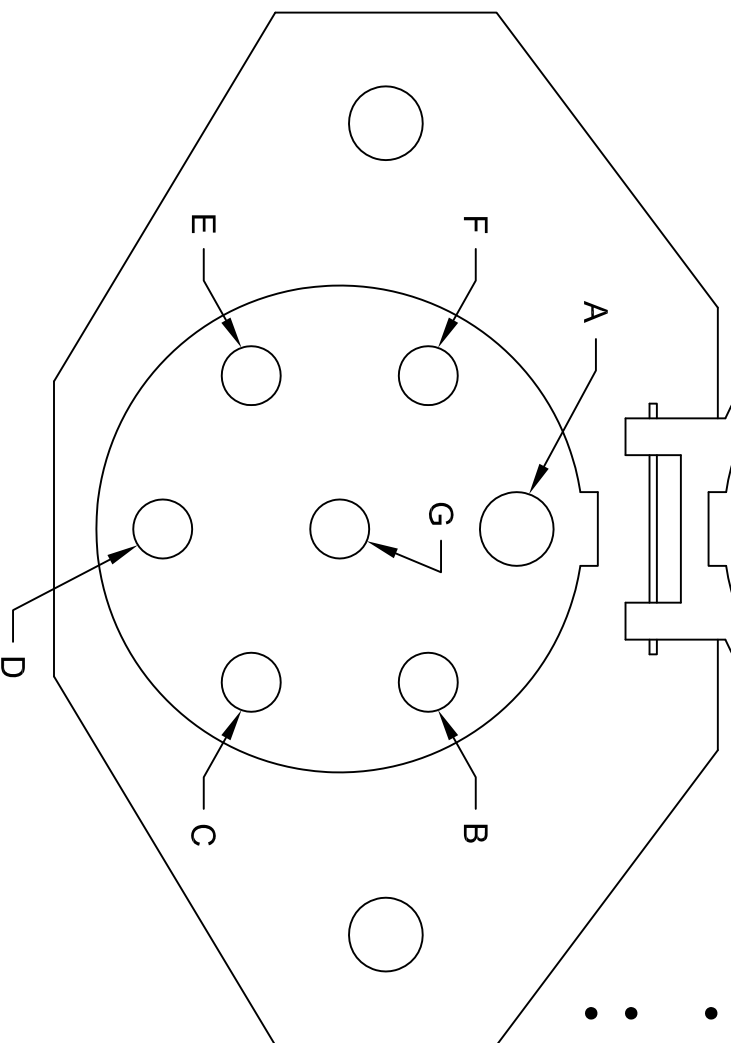
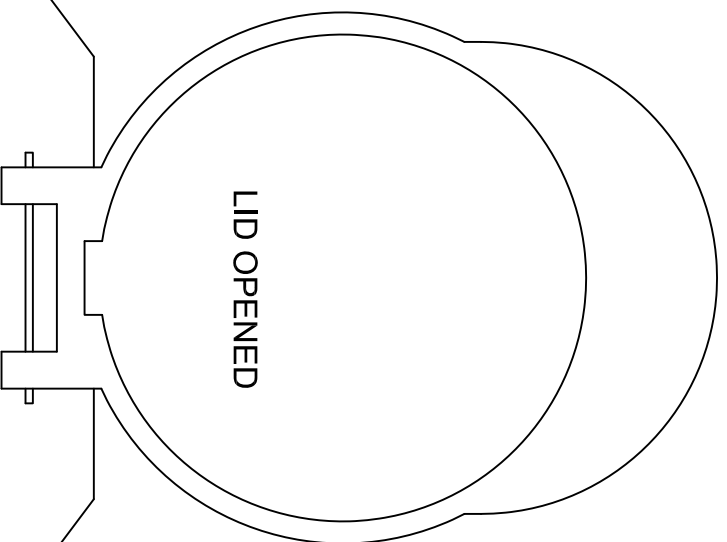

LID CLOSED

NOTES:

- VIEW OF FEMALE CONNECTOR, STANDING AT REAR OF TRUCK, LOOKING AT THE CONNECTOR.
- BRAKE LIGHTS SHALL FUNCTION WITH TURN SIGNALS.
- WIRE SHALL BE 7 WAY (1-10 GAUGE; 6-12 GAUGE) PER ATA COLOR CODE, CLAMPED EVERY 18" MINIMUM.
- CONNECTION SHALL BE MADE USING FACTORY OEM TRAILER WIRING HARNESS.
- ALL CONNECTIONS SHALL BE WATER TIGHT.
- ALL PINS SHALL BE ROUND STYLE.

WIRING NOTES:

- A. WHITE: GROUND - 10
- B. BLACK: MARKER -12
- C. YELLOW: LEFT TURN & BRAKE - 12
- D. RED: STOP / BRAKE -12
- E. GREEN: RIGHT TURN & BRAKE - 12
- F. BROWN: TAIL - 12
- G. BLUE: ABS -12

PA DEPARTMENT OF TRANSPORTATION

REVISIONS

NO.	DATE	BY	DESCRIPTION
1	08-02-18	KBD	WIRING DIAGRAM / 7 WAY ROUND PIN FEMALE CONNECTOR
2			
3			

WIRING DIAGRAM / 7 WAY ROUND

PIN FEMALE CONNECTOR

DRAWN BY JJB EQN-80A

DATE 08-02-16 SHEET 1 OF 1

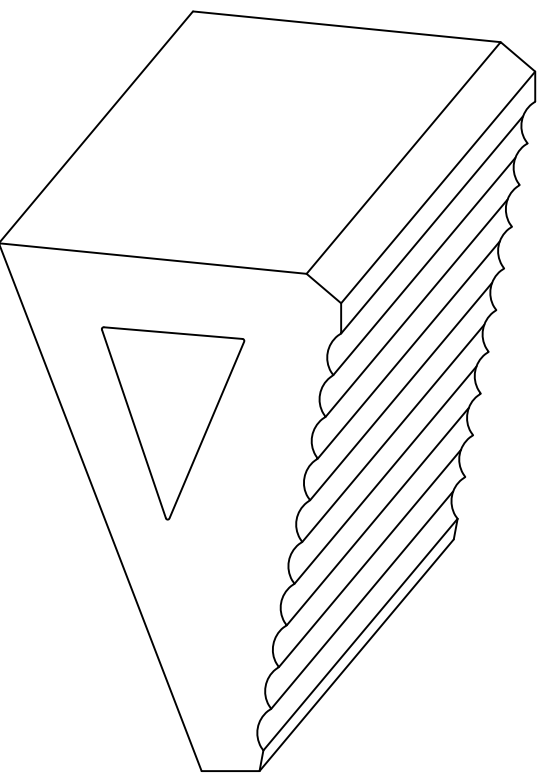
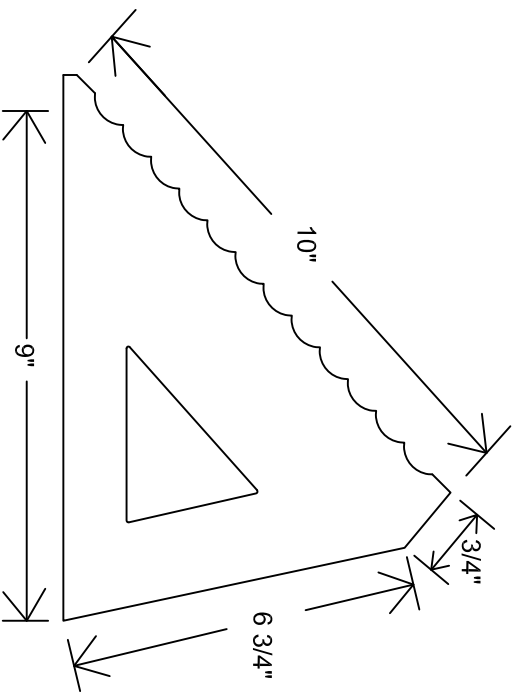

FINAL MOUNTING LOCATION SHALL BE DETERMINED AT THE PRE-BUILD MEETING. CHOCK HOLDERS SHALL BE ALUMINUM OR STAINLESS STEEL. TWO CHOCKS PER TRUCK SHALL BE SUPPLIED. CHOCKS SHALL HAVE 4 FEET OF $\frac{3}{8}$ INCH NYLON ROPE CONNECTING THE TWO CHOCKS TOGETHER.

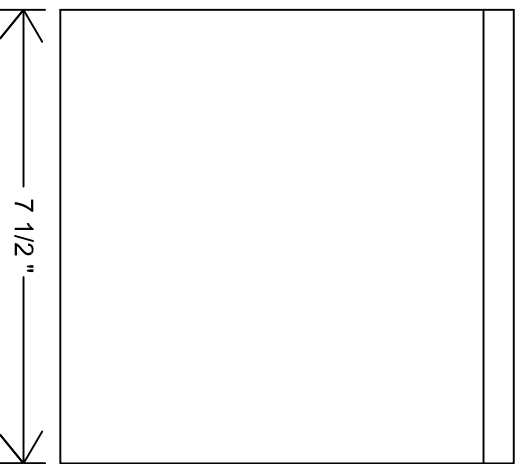

PA DEPARTMENT OF TRANSPORTATION

REVISIONS			6 3/4" X 9" X 7 1/2" CHOCK AND HOLDER		
NO.	DATE	BY	DRAWN BY	SCALE	EQN-82B
1			HMR	N/A	
2					
3					

DATE 07-17-17 SHEET 1 OF 1

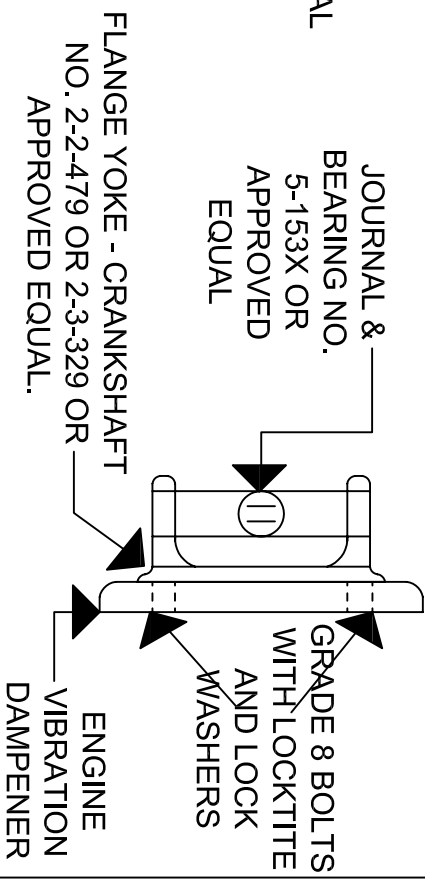
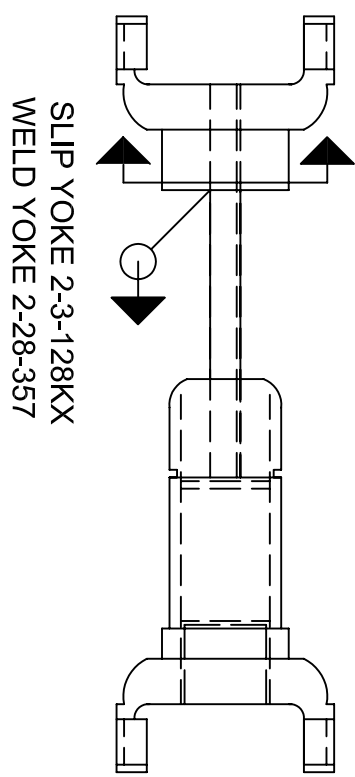
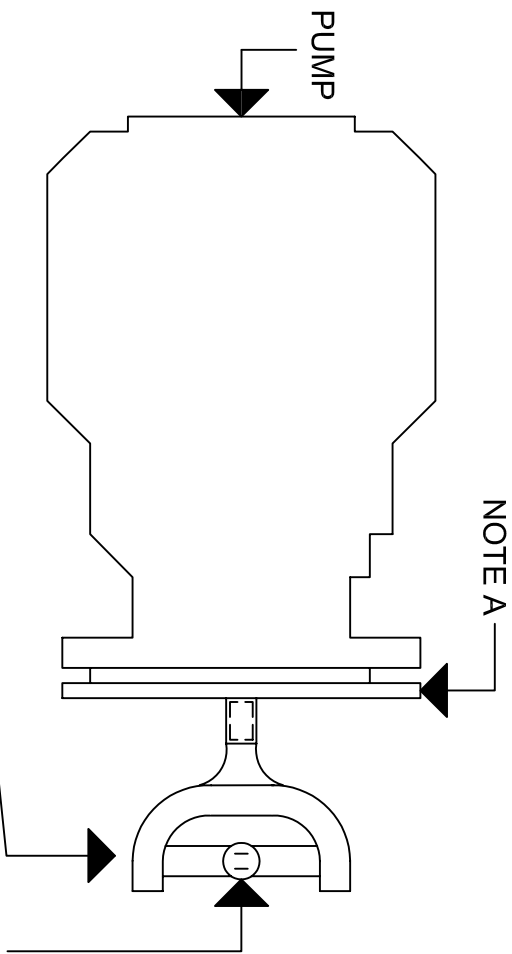

NOTE A
PUMP MOUNTING BRACKET SHALL BE $\frac{5}{8}$ in., MINIMUM, FORMED STEEL CHANNEL. AS PER EQN - 90 SHEET 2

NOTES:

- 1.) DRIVESHAFT ASSEMBLY SHALL BE FACTORY BALANCED.
- 2.) SPICER 1310 SERIES, OR NEAPCO. NO SUBSTITUTE. STANDARDIZATION.
- 3.) SLEEVE YOKE SHALL BE 1.375 in. I.D. 16 SPLINES.
- 4.) END YOKE ADAPTER SHALL ACCOMMODATE 1.5 in., KEYED SHAFT.

PA DEPARTMENT OF TRANSPORTATION

REVISIONS

NO.	DATE	BY	DUMP TRUCK PTO ASSEMBLY		
1	4-6-07	KNH	DRAWN BY	DLW	SCALE
2	07-20-09	TOD	DATE	07/17/97	CHKD BY
3					WHM SHEET 1 OF 2

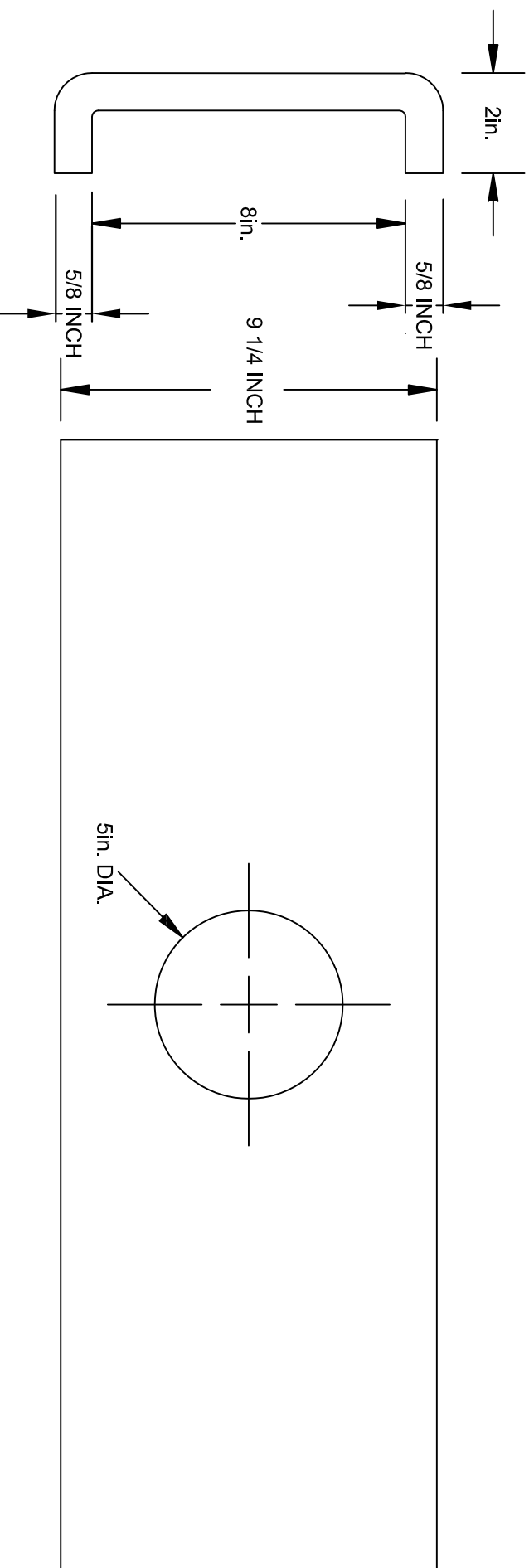

PUMP MOUNTING BRACKET, REGARDLESS OF DESIGN, SHALL BE A MINIMUM 5/8 in. FORMED STEEL CHANNEL. THE PUMP BRACKET SHALL BE SLOPED TO MATCH THE ENGINE CRANKSHAFT. WIDTH DIMENSION SHALL BE FULL FRAME RAIL WIDTH. BRACKETRY TO ATTACH PUMP MOUNTING BRACKET TO TRUCK FRAME RAILS SHALL BE MINIMUM 5/8 in. THICKNESS. BRACKETS SHALL BE EITHER FULLY WELDED OR USE 3/4 in. GRADE 8 BOLTS OF SUFFICIENT LENGTH AND GRADE 8 LOCK NUTS, MINIMUM TWO BOLTS PER MOUNTING SURFACE.

PA DEPARTMENT OF TRANSPORTATION

REVISIONS			PUMP MOUNTING BRACKET		
NO.	DATE	BY	SCALE	DRAWN BY	
1	07-03-97	DLW		SWW	EQN-90
2	06-03-02	DWVG			
3	07-20-09	TOD		RED	SHEET 2 OF 4

HYDRAULIC HOSES/ FITTINGS

HYDRAULIC HOSES SHALL NOT EXTEND BELOW THE TOP OF THE FRONT AXLE. ALL HYDRAULIC HOSES SHALL BE ADEQUATELY CLAMPED, SHIELDED FROM EXHAUST SYSTEM AND PREVENTED FROM RUBBING UP AGAINST ANY PART OF THE TRUCK FRAME BODY.

HYCON CLAMPS AS REQUIRED TO PREVENT CHAFFING OR RUBBING. DUE TO THE VARIATIONS OF SIZES PART NUMBERS HAVE NOT BEEN INCLUDED. WELD-ON OR BOLT-ON ARE ACCEPTABLE. AVAILABLE IN STANDARD AND HEAVY DUTY SERIES. LOCATIONS TO BE APPROVED BY CHIEF, FLEET MANAGEMENT DIVISION
REF: HYCON CORPORATION, LEHIGH VALLEY, PA OR BEHRINGER PIPE SYSTEM INC.

NOTE:

ALL BOLTS/NUTS SHALL BE COATED WITH NEVER SIEZE.

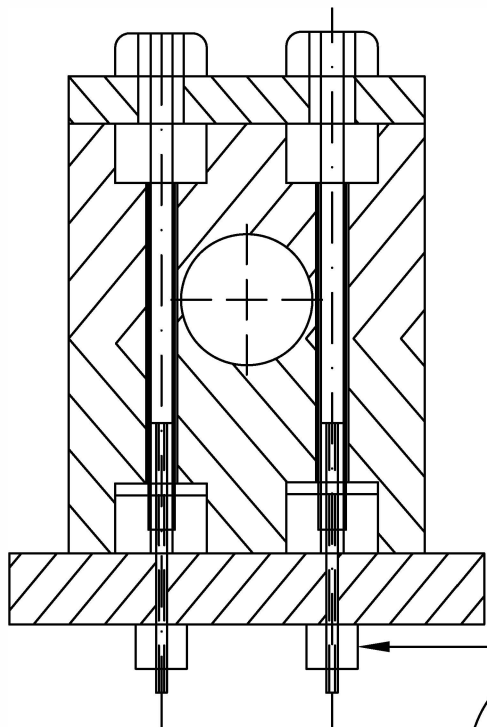

BOLT SHALL EXTEND BEYOND BASE

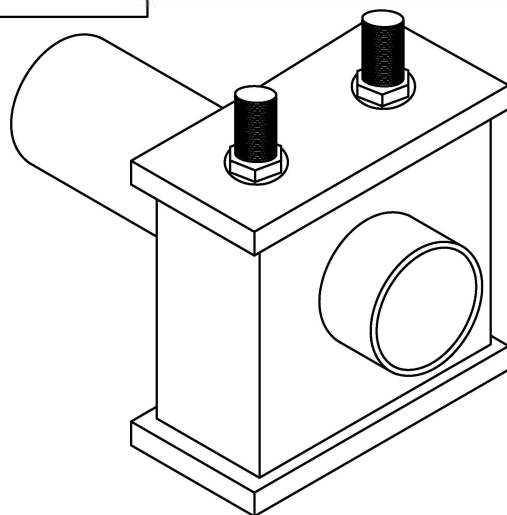

PA DEPARTMENT OF TRANSPORTATION						
REVISIONS			Hydraulic Hose Mounting & Requirements			
NO.	DATE	BY	DRAWN BY	Checked With		
1	10-02-06	CJW	RED	EQN-23	EQN-94	
2	12-20-16	JJB				
3	08-02-18	KBD	DATE	11-03-78	CHK'D BY	Scale
					N/A	N/A
						SHEET 1 OF 5

FRONT COUPLERS SHALL BE MOUNTED TO A MANIFOLD PLATE POSITIONED IN THE CENTER OF THE FRONT FRAME EXTENSION WHICH HOUSES THE PTO ASSEMBLY. MOUNTING SEQUENCE SHALL BE AS FOLLOWS MOVING TOP TO BOTTOM WHEN FACING THE RIGHT SIDE OF THE VEHICLE:

TWO (2) WING COUPLERS: UPPER BEING 5100-S2-8B AEROQUIP MALE AND LOWER BEING 5100-S1-8B AEROQUIP FEMALE

REAR COUPLERS SHALL BE MOUNTED TO A MANIFOLD PLATE ATTACHED AND CENTERED TO THE BOTTOM OF REAR FRAME CROSS MEMBER OR MOUNTED THROUGH REAR CROSS MEMBER IF POSSIBLE. MOUNTING SEQUENCE SHALL BE AS FOLLOWS MOVING TOP TO BOTTOM WHEN FACING THE RIGHT SIDE OF THE VEHICLE:

TWO (2) LIFT WING COUPLERS: UPPER BEING 5100-S2-8B AEROQUIP MALE AND LOWER BEING 5100-S1-8B AEROQUIP FEMALE

TWO (2) EXTEND WING COUPLERS: UPPER BEING 5100-S2-8B AEROQUIP MALE AND LOWER BEING 5100-S1-8B AEROQUIP FEMALE

COUPLERS SHALL HAVE DUST PLUGS AFFIXED WITH CHAINS TO PREVENT LOSS OF CAPS.

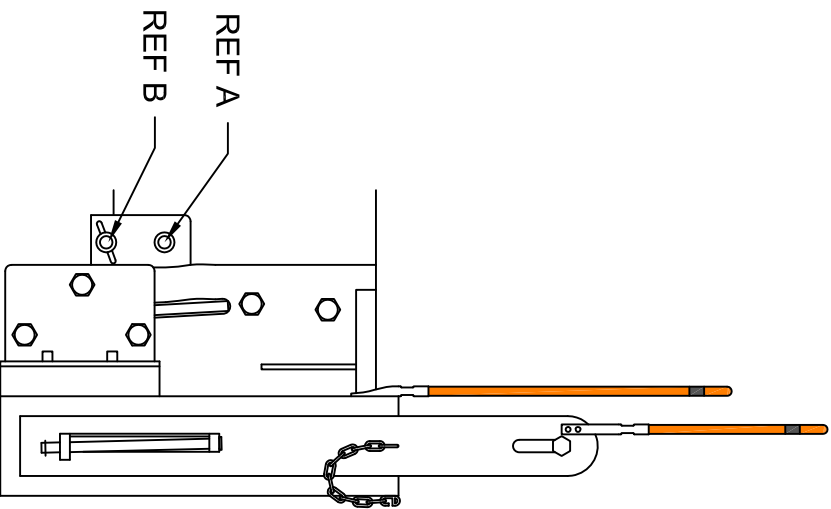

NOTES:
 A. 5100-S2-8B MALE
 B. 5100-S1-8B FEMALE

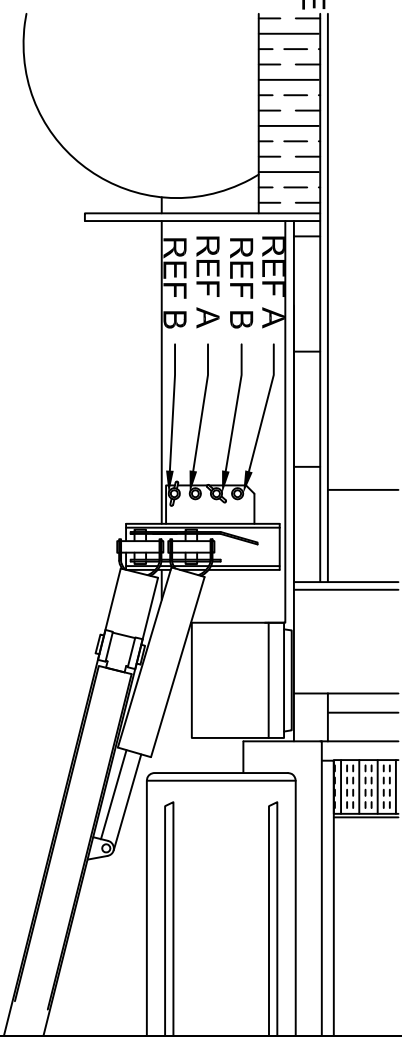

FRONT COUPLERS

PA DEPARTMENT OF TRANSPORTATION

REVISIONS

NO.	DATE	BY	DESCRIPTION
1	12-20-16	JJB	
2	07-13-17	HMR	
3	08-02-18	KBD	

Wing Plow Couplers

DRAWN BY	CHK'D BY	Scale	EQN-94
RED	N/A	N/A	
DATE	DATE		SHEET 2 OF 5
11-03-78	N/A		

Two (2) Plow Hitch Couplers: LOCATED ON DRIVER SIDE OF HITCH ASSEMBLY RIGHT COUPLER BEING 5100-S2-8B AERROQUIP MALE ATTACHING TO FEMALE COUPLER ON PLOW RAM AND LEFT COUPLER BEING 5100-S1-8B AERROQUIP FEMALE ATTACHING TO MALE COUPLER ON PLOW RAM.

Two (2) Two Way Plow Couplers: LOCATED ON PASSENGER SIDE OF HITCH ASSEMBLY LEFT COUPLER BEING 5100-S2-8B AERROQUIP MALE ATTACHING TO FEMALE COUPLER ON TWO WAY PLOW AND RIGHT COUPLER BEING 5100-S1-8B AERROQUIP FEMALE ATTACHING TO MALE COUPLER ON TWO WAY PLOW.

FRONT VIEW

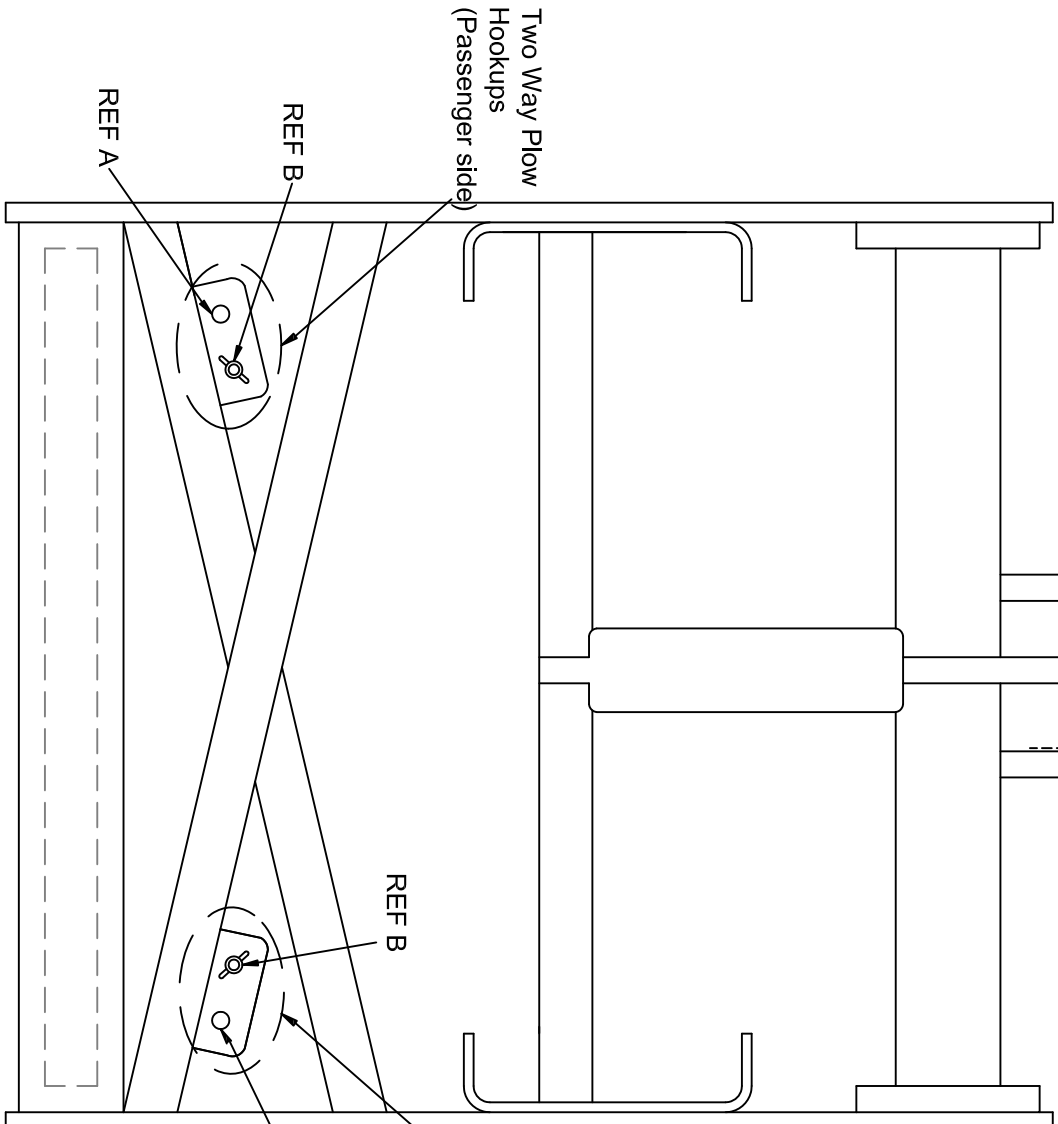

HYDRAULIC HOSES SHOULD'NT INTERFEAR WITH ANYTHING WHILE TWO WAY PLOW AND PLOW HITCH IS IN MOTION AND AT REST TO PREVENT DAMAGE TO HOSES.

NOTES:

- A. 5100-S2-8B MALE
- B. 5100-S1-8B FEMALE

Plow Ram Hooks (Driver Side)

Two Way Plow Hooks (Passenger side)

PA DEPARTMENT OF TRANSPORTATION

REVISIONS

NO.	DATE	BY	DESCRIPTION
1	04-27-15	GAW	Ram Plow & Two Way Plow Couplers
2	12-19-16	JJB	
3	08-02-18	KBD	

DRAWN BY	SWW	CONTINUED WITH	EQN-94
CHECKED BY	N/A	SCALE	
DATE	09-25-95		SHEET 4 OF 5

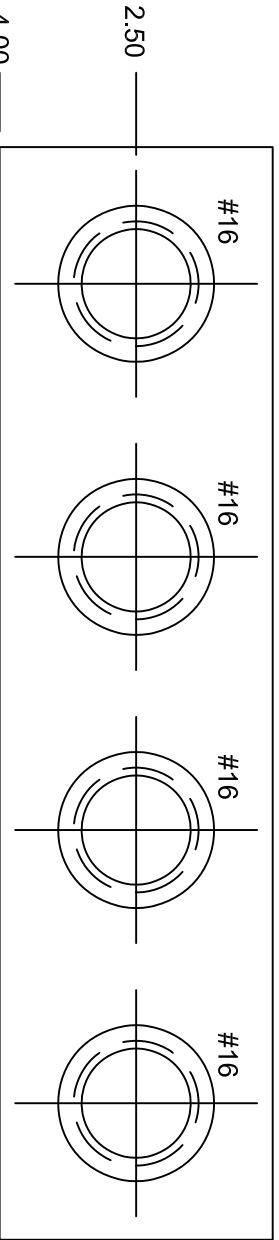
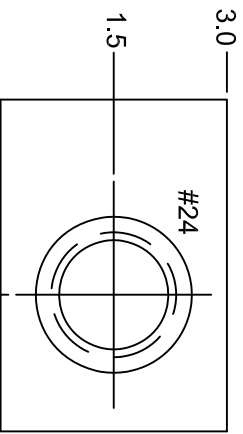
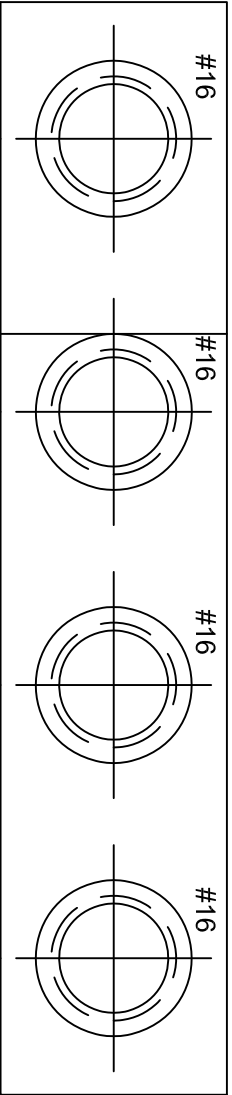
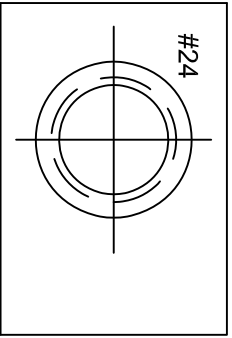

PA DEPARTMENT OF TRANSPORTATION

REVISIONS

2 Hydraulics Components Overview

Header Block

NO.	DATE	BY	DRAWN BY	DATE	CHKD BY	SCALE	SHEET
1	08-03-01	DWG	GAH	03-01-00	N/A	N/A	5 OF 5
2	11-02-06	CJW	GAH	03-01-00	N/A	N/A	5 OF 5
3	08-02-18	KBD					5 OF 5

SECTION 393.86 READS AS FOLLOWS: "EVERY MOTOR VEHICLE, EXCEPT TRUCK-TRACTORS, POLE TRAILERS, AND VEHICLES IN DRIVEWAY-TOWAWAY OPERATIONS, THE DATE OF MANUFACTURE OF WHICH IS SUBSEQUENT TO DECEMBER 31, 1952, WHICH IS SO CONSTRUCTED THAT THE BODY OR THE CHASSIS ASSEMBLY IF WITHOUT A BODY HAS A CLEARANCE AT THE REAR END OF MORE THAN 30 in. FROM THE GROUND WHEN EMPTY, SHALL BE PROVIDED WITH BUMPERS OR DEVICES SERVING SIMILAR PURPOSES WHICH SHALL BE SO CONSTRUCTED AND LOCATED THAT: (A) THE CLEARANCE BETWEEN THE EFFECTED BOTTOM OF THE BUMPERS OR DEVICES AND THE GROUND SHALL NOT EXCEED 30 in. WITH VEHICLE EMPTY; (B) THE MAXIMUM DISTANCE BETWEEN THE CLOSEST POINTS BETWEEN BUMPERS, OR DEVICES, IF MORE THAN ONE IS USED, SHALL NOT EXCEED 24 in.; (C) THE MAXIMUM TRANSVERSE DISTANCE FROM THE WIDEST PART OF THE MOTOR VEHICLE AT THE REAR TO THE BUMPER OR DEVICE SHALL NOT EXCEED 18 in.; (D) THE BUMPER OR DEVICES SHALL BE LOCATED NOT MORE THAN 24 in. FORWARD OF THE EXTREME REAR OF THE VEHICLE; (E) AND THE BUMPER OR DEVICES SHALL BE SUBSTANTIALLY CONSTRUCTED AND FIRMLY ATTACHED. MOTOR VEHICLES CONSTRUCTED AND MAINTAINED SO THAT THE BODY, CHASSIS, OR OTHER PARTS OF THE VEHICLE AFFORD THE REAR END PROTECTION CONTEMPLATED SHALL BE DEEMED TO BE IN COMPLIANCE WITH THIS SECTION."

THE REGULATIONS ALSO REQUIRE ALL MOTOR VEHICLES TRANSPORTING HAZARDOUS MATERIALS REQUIRING PLACARDING BE EQUIPPED WITH REAR END PROTECTION (REFERANCE 49CFR PART 397, 49 CFR SECTION 177.823, 49 CFR PART 172, AND 49 CFR SECTION 171.12A).

ALTHOUGH SECTION 393.86 DOES NOT SET FORTH SPECIFIC PERFORMANCE REQUIREMENTS FOR THE REAR END PROTECTION STRUCTURE, SUBPART J - SPECIFICATIONS FOR CONTAINERS FOR MOTOR VEHICLE TRANSPORTATION OF PART 178 - SHIPPING CONTAINER SPECIFICATIONS OF SUBCHAPTER C - HAZARDOUS MATERIAL REGULATIONS OF CHAPTER I - RESEARCH AND SPECIAL PROGRAMS ADMINISTRATION DOES CONTAIN SPECIFIC PERFORMANCE REQUIREMENTS FOR REAR END PROTECTION ON CARGO TANK MOTOR VEHICLES (REFERENCE SECTIONS 178.337-10(D), 178.338-10(C), 178.345-8(D), 178.346-8, 178.347-8, AND 178.348-8). PENNSYLVANIA HAS ADOPTED 49 CFR 393.86 REAR END PROTECTION FOR COMMERCIAL MOTOR VEHICLES WITH A GVW OF 17,000 lbs. / 7711.07 kg. OR MORE OPERATED IN INTRASTATE COMMERCE, AND ANY SIZE VEHICLE HAULING HAZARDOUS MATERIALS REQUIRING PLACARDS WITH AN ADDITIONAL REQUIREMENT: "SOME PART OF THE HORIZONTAL BUMPER BAR SHALL FALL WITHIN 16-30in. / 40.64-76.2cm. ABOVE GROUND LEVEL." SEE TITLE 67 CHAPTER 175 OF THE PENNSYLVANIA CODE FOR THE SPECIFIC REQUIREMENTS FOR REAR END PROTECTION ON COMMERCIAL MOTOR VEHICLES WITH A GVW OF 10,001-17,000 lbs. / 4536.38-7711.07 kg. OPERATED IN INTRASTATE COMMERCE.

**COMMONWEALTH OF PENNSYLVANIA
DEPARTMENT OF TRANSPORTATION**

REVISIONS

NO.	DATE	BY	UNDERRIDE PROTECTION
1	07/08/97	DLW	
2	07/01/03	KGK	
3	06/26/09	TOD	

UNDERRIDE PROTECTION

NO.	DATE	BY	UNDERRIDE PROTECTION
1	07/08/97	DLW	
2	07/01/03	KGK	
3	06/26/09	TOD	

**ANY / ALL REVISIONS SHALL
SUPERSEDE THE ABOVE**

DATE	02-04-92	SCALE	N/A	EQN -118
DRAWN BY	DLW	CHECKED BY	RR	SHEET 1 OF 1

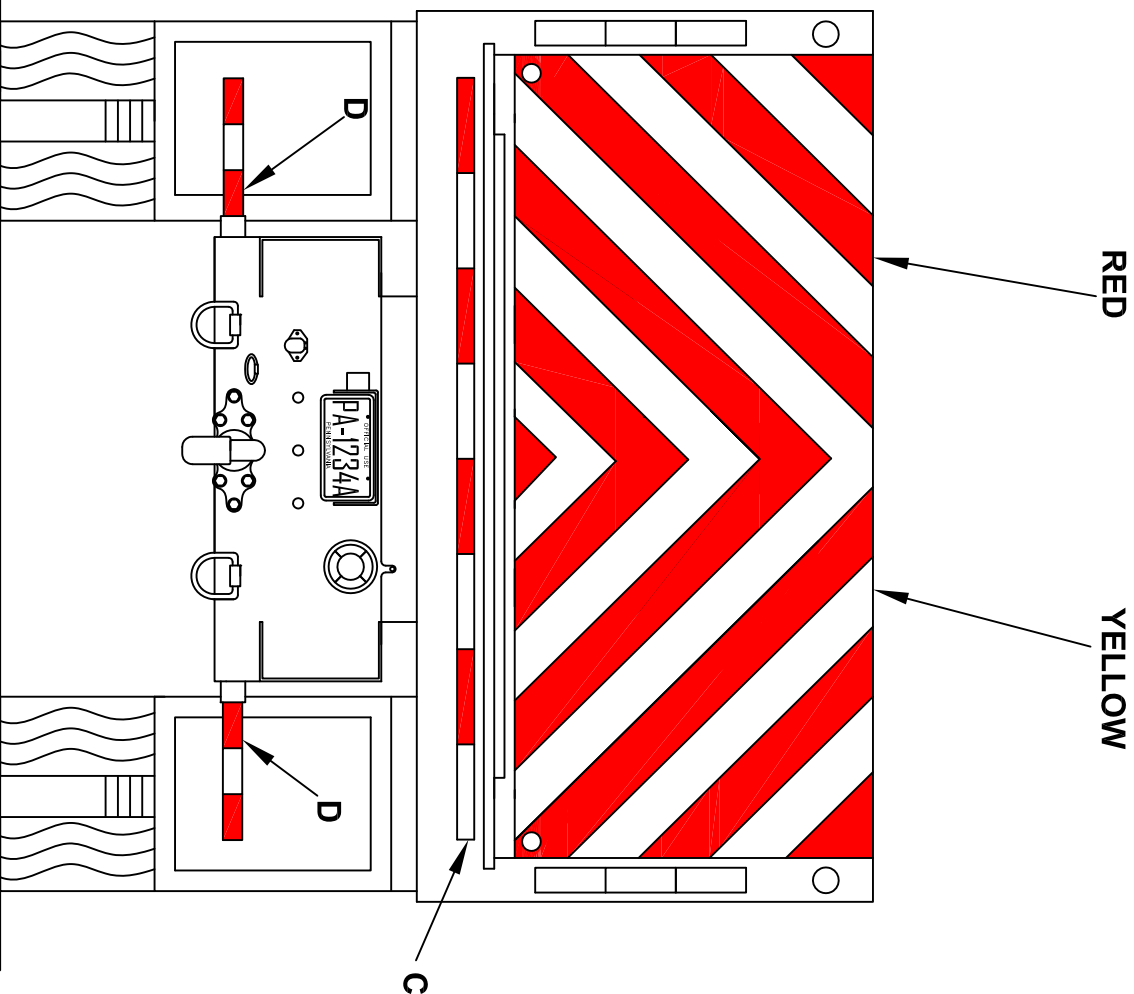

A THE ALUMINUM TAILGATE SHALL BE UNPAINTED. THE TAILGATE SHALL BE STRIPED AS SHOWN WITH 8" WIDE ALTERNATING RED/YELLOW BANDS CREATING A CHEVRON (INVERTED V) AT 45 DEGREE ANGLES, ACROSS THE GATE TO SERVE AS A SAFETY WARNING SYSTEM.

B TAPE SHALL BE REFLEXITE DAYBRIGHT V92 CONSPICUITY SHEETING. RED - SRH14R PN# 18716, LIME - SRH14Y PN# 18836 VC 312. TWO 4" SHEETS CAN BE COMBINED TO EQUAL THE 8" REQUIREMENT.

C THE ENTIRE WIDTH DIRECTLY UNDER THE TAILGATE SHALL BE COVERED WITH 1 1/2" WIDE SCOTCHLITE CONSPICUITY SHEETING SERIES 980 OR REFLEXITE CONSPICUITY II SYSTEM. MATERIAL SHALL BE RED/SILVER, CONTINUOUS BACKING.

D THE ENTIRE LENGTH OF BOTH ICC BARS SHALL BE COVERED WITH 1 1/2" WIDE SCOTCHLITE CONSPICUITY SHEETING SERIES 980 OR REFLEXITE CONSPICUITY II SYSTEM. MATERIAL SHALL BE RED/SILVER, CONTINUOUS BACKING.

THIS DRAWING SHALL BE FOR CONSPICUITY REFERENCE ONLY, NOT TAILGATE CONSTRUCTION.

THIS VEHICLE SHALL COMPLY WITH THE RULES OF THE NATIONAL HIGHWAY TRAFFIC SAFETY ADMINISTRATION (NHTSA). THE MOST CURRENT REGULATIONS SHALL BE ADHERED TO.

PA DEPARTMENT OF TRANSPORTATION

REVISIONS

NO.	DATE	BY	REASON
1	05-20-13	JFM	REFLECTIVE SHEETING
2	06-30-14	ACT	REFLECTIVE SHEETING
3	07-24-18	KBD	REFLECTIVE SHEETING

DUMP BODY

REFLECTIVE SHEETING

NO.	DATE	BY	REASON
1	05-20-13	JFM	REFLECTIVE SHEETING
2	06-30-14	ACT	REFLECTIVE SHEETING
3	07-24-18	KBD	REFLECTIVE SHEETING

DRAWN BY: GRL
 CHECKED BY: [Signature]
 DATE: 10-11-94
 SHEET 1 OF 3

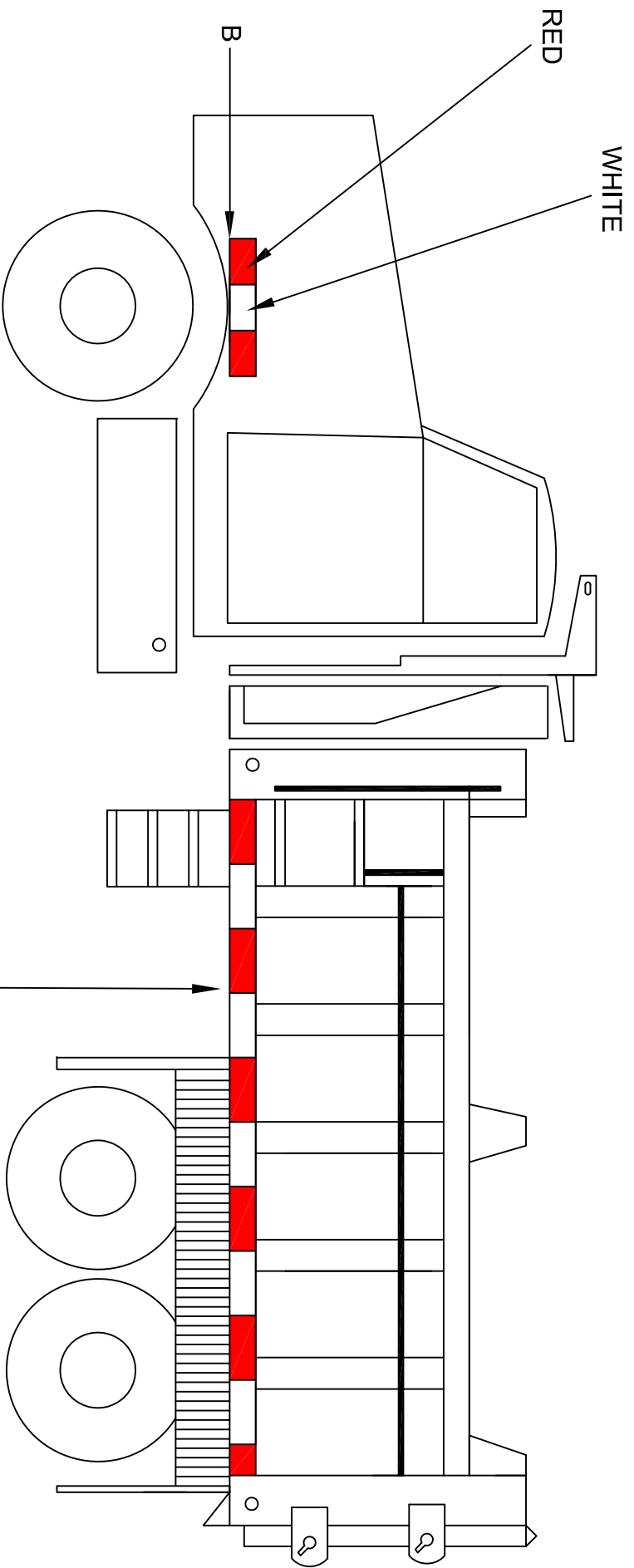

A THE ENTIRE LENGTH OF BODY RUB RAILS SHALL BE COVERED WITH 2" WIDE SCOTCHLITE CONSPICUITY SHEETING SERIES 980 OR REFLEXITE CONSPICUITY II SYSTEM MATERIAL SHALL BE RED/SILVER, CONTINUOUS BACKING.

B THE AREA ABOVE FRONT TIRES SHALL BE COVERED WITH MINIMUM 18 INCHES, 2" WIDE SCOTCHLITE CONSPICUITY SHEETING SERIES 980 OR REFLEXITE CONSPICUITY II SYSTEM MATERIAL SHALL BE RED/SILVER, CONTINUOUS BACKING. ITEM B NEEDS TO BE AS CLOSE AS POSSIBLE IN A STRAIGHT LINE WITH ITEM A. ALTERNATE PLACEMENT OF ITEM B NEEDS TO BE APPROVED BY THE CHIEF OF THE EQUIPMENT DIVISION

THE CHIEF OF THE EQUIPMENT DIVISION SHALL APPROVE ALL STRIPING AND MONITOR THE PRODUCTION BY THE SUCCESSFUL VENDOR. ALL DIMENSIONS IN INCHES.

PA DEPARTMENT OF TRANSPORTATION

REVISIONS			DRAWN BY	
NO.	DATE	BY	TOD	
1	05-20-13	JFM	EQU-122	
2	06-30-14	ACT	Checked With	
3	07-24-18	KBD	DATE	07-14-09

DUMP BODY REFLECTIVE SHEETING

SHEET 2 OF 3

THIS VEHICLE SHALL COMPLY WITH THE RULES OF THE NATIONAL HIGHWAY TRAFFIC SAFETY ADMINISTRATION (NHTSA) IN THAT:

THE MOUNTING HEIGHT OF THE HORIZONTAL STRIPES ARE RESTRICTED TO THE SAME HEIGHT AS OTHER RETROREFLECTIVE DEVICES CURRENTLY REQUIRED BY STANDARD NUMBER 108. THE CENTER OF THE MATERIAL MUST NOT BE LESS THAN 15in. ABOVE THE ROAD SURFACE, AND THE UPPER EDGE NOT MORE THAN 60in. ABOVE IT.

REFLECTIVE MATERIAL SHALL BE APPLIED TO THE HORIZONTAL BAR OF THE REAR UNDERIDE DEVICE IN ADDITION TO THE FLOOR LEVEL HORIZONTAL STRIPE. THE UPPER CORNERS ARE TO BE MARKED BY TWO 90 DEGREE ANGLE BRACKETS OF WHITE STRIPES 12in. BY TWO INCHES WIDE, INDICATING THE WIDTH AND HEIGHT OF THE TRAILER.

THE CONFIGURATION SHALL IDENTIFY THE VEHICLE AS TO ITS ESTIMATED SIZE AND THE CLOSING DISTANCE TO IT. THE DISTRIBUTION OF SPACES AND MATERIALS SHALL BE AS UNIFORM AS PRACTICAL AND INDICATE THE FULL LENGTH AND WIDTH OF THE VEHICLE. THE COLORS SHALL BE PLACED IN ALTERNATING SEQUENCE WITH MORE THAN TWO-THIRDS OF THE MATERIAL IN COLOR.

CONSPICUITY TAPE SHALL BE REFLECTORIZED. 2in. WIDE, MATERIAL SHALL BE APPLIED. MATERIAL SHALL BE RED/SILVER CONTINUOUS BACKING REFLEXITE CONSPICUITY II SYSTEM OR 3M SCOTCHLITE CONSPICUITY SHEETING SERIES 980.

THE MOST CURRENT REGULATIONS SHALL BE ADHERED TO.

PA DEPARTMENT OF TRANSPORTATION			CONSPICUITY TAPE STRIPING REQUIREMENTS		
REVISIONS			DRAWN BY		
NO.	DATE	BY	DLW	Checked VTR	EQN-122
1	11-03-06	CJW			
2	01-02-09	MHH			
3	07-24-18	KBD	DATE	CHKD BY	Scale
			11-07-97		
					SHEET 3 OF 3

NOTE : THIS LIGHT DESIGN IS ONE OF TWO LIGHT DESIGN THAT ARE ACCEPTABLE

PLATE MOUNTED FAST TO TRUCK

ADDITIONAL HOLES TO ALLOW 6" OF VERTICAL HEIGHT ADJUSTMENT (3" UP AND 3" DOWN FROM ORIGINAL HEIGHT)

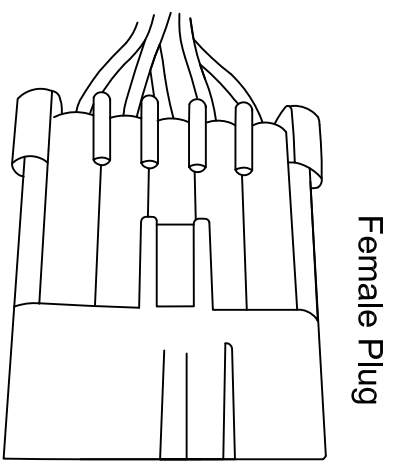

Packard 5 Way

Male Plug & Terminals

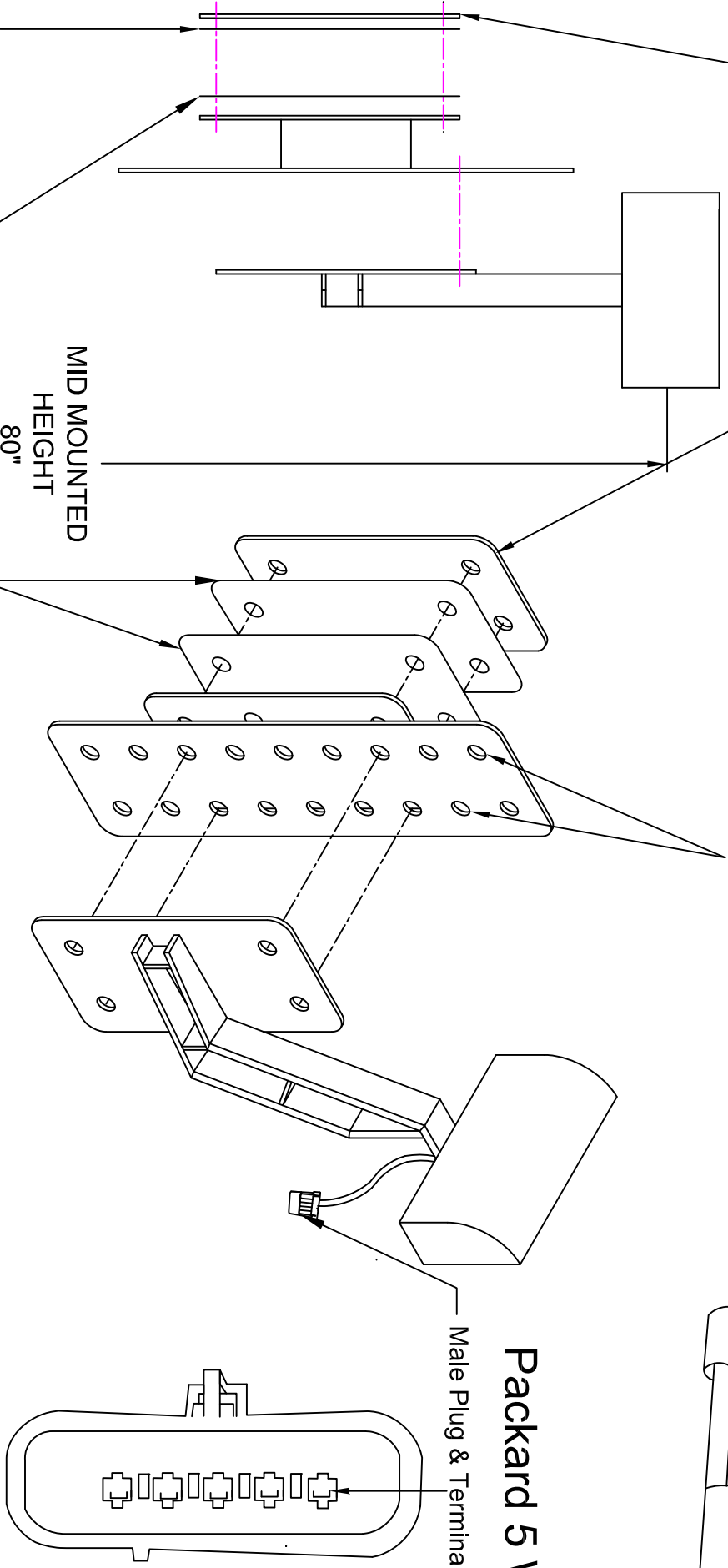

GROUND LEVEL

PA DEPARTMENT OF TRANSPORTATION			
REVISIONS		HEADLIGHT ADJUSTMENT BRACKET	
NO.	DATE	BY	
1	07-26-18	KBD	
2			
3			

DRAWN BY	JJB	Checked With		EQN-180
DATE	07-19-16	CHG BY	TSPH	SHEET 1 OF 2
			N/A	

NOTE : THIS LIGHT DESIGN IS ONE OF TWO LIGHT DESIGN THAT ARE ACCEPTABLE

Packard 5 Way

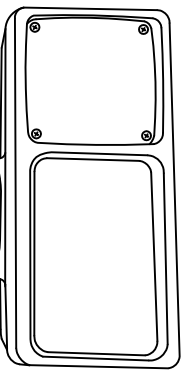

Light Front View

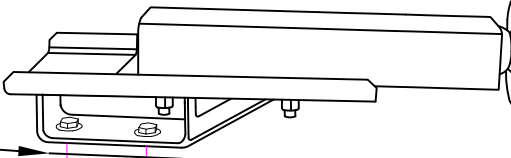

Protective Liner

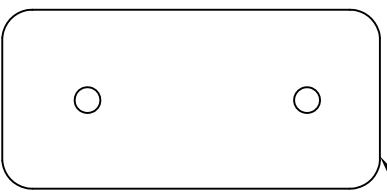

Light Bracket

Female Plug

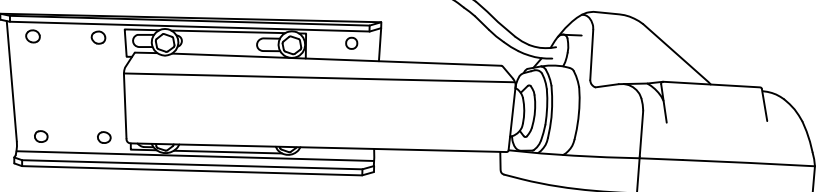
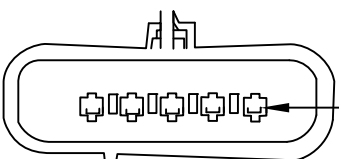
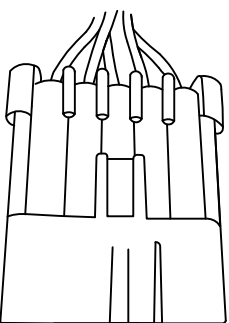

Light Side View

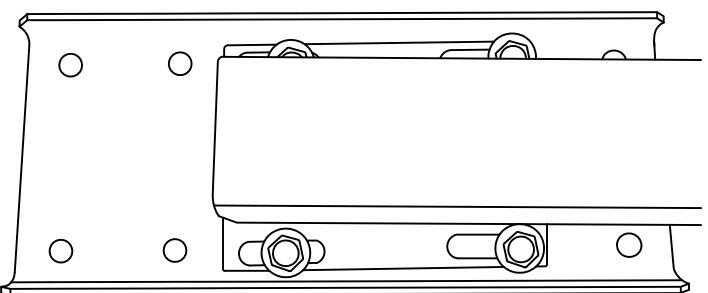

PA DEPARTMENT OF TRANSPORTATION

REVISIONS

Plow Truck Light & Bracket

NO.	DATE	BY	DRAWN BY	Checked by	Scale	Sheet
1			KBD			EQN-180
2						
3						

DATE 07-26-18

Sheet 2 OF 2

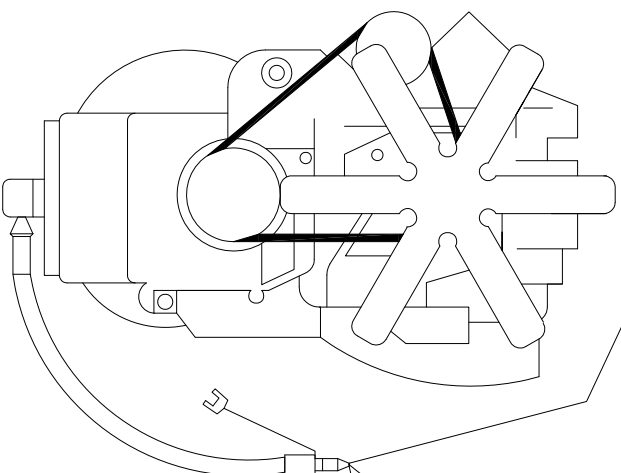
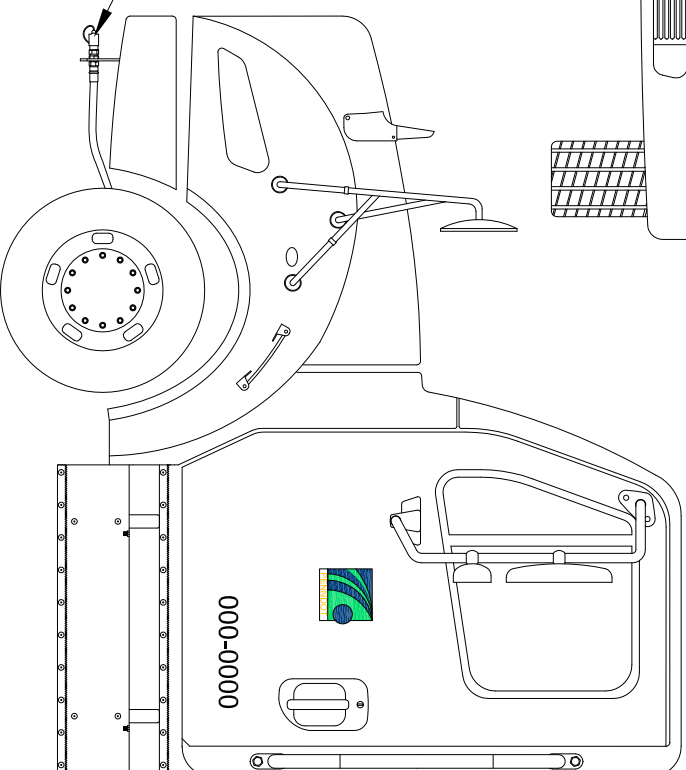
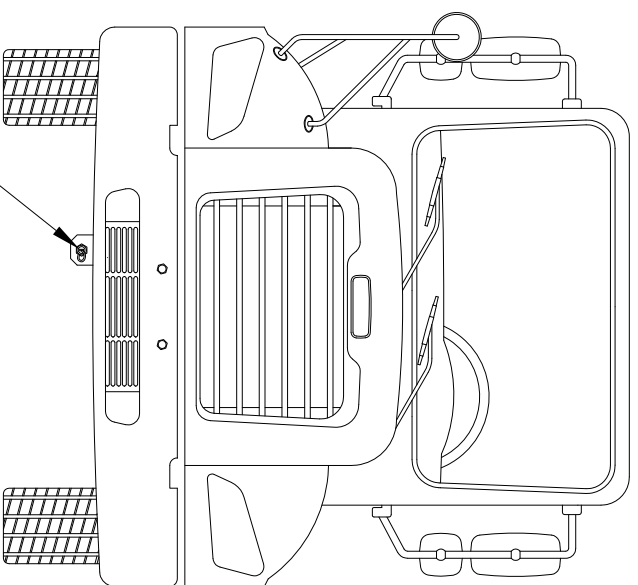
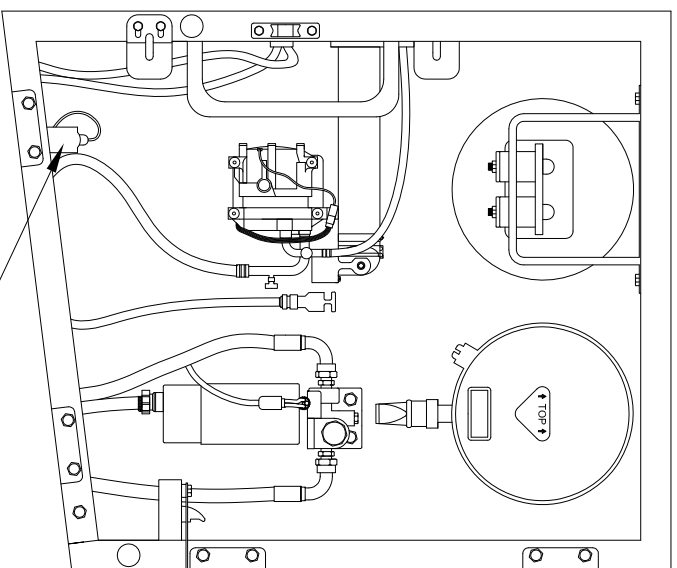

DISCONNECT
COUPLING
FLOCS
ENGINE KIT

PA DEPARTMENT OF TRANSPORTATION

REVISIONS

NO	DATE	BY	FAST LUBE OIL CHANGE SYSTEM OVERVIEW AND PARTS LIST
1	07-01-03	BLD	
2	10-20-06	CJW	
3	06-19-13	JFM	

**FAST LUBE OIL CHANGE SYSTEM
OVERVIEW AND PARTS LIST**

DATE	DRAWN BY	SCALE	EQN-351A
08-22-97	DLW	N/A	

1. CONTACT AEROQUIP WITH YOUR DRAIN PAN PLUG SIZE
2. AEROQUIP DEALER TELEPHONE NUMBERS:

ADVANCED FLUID CONNECTORS..... 717-757-1068
 AIR BRAKE & POWER EQUIPMENT CO.. 717-622-6188
 AMERICAN BEARING & POWER..... 717-569-3291
 GOODALL RUBBER COMPANY 610-534-2100
 POWER DRIVES INC..... 814-833-8181
 R L MILLER INC..... 412-833-6800
 R L MILLER INC..... 814-456-8900
 SRG/BEVCO..... 610-358-3100
 VOTO MANUFACTURERS SALES CO.... 814-226-7101

FLOCS SHALL INCLUDE, BUT NOT LIMITED TO:

- A. DUST CAP 5657-12
- B. HOSE TO SUIT LENGTH
- C. HOSE FITTING TO SUIT
- D. ADAPTER TO SUIT
- E. HOSE CLAMP #900729-6
- F. BRACKET TO SUIT
- G. COUPLING 5602-12-12S

PA DEPARTMENT OF TRANSPORTATION

REVISIONS		FAST LUBE OIL CHANGE SYSTEM OVERVIEW AND PARTS LIST	
NO	DATE	BY	
1	07-01-03	BLD	
2	10-20-06	CJW	SCALE N/A
3	06-19-13	JFM	DATE 08-22-97

Centralized Lubrication System On Road Equipment EQN - 501

There shall be an automatic centralized lubrication system professionally installed to maintain all the daily, weekly, and monthly lubrication points. Only electrically controlled, #2 chassis grease systems shall be accepted. The use of pneumatic systems is unacceptable. The requirements for the lubrication system components and installation procedures are outlined below. It is the responsibility of the vendor to ensure that the automatic lubrication system complies with all of these requirements.

1. Performance Requirements

- The system pump shall be capable of delivering NLGI #2 grease over a temperature range of minus 10 degrees Fahrenheit to 120 degrees Fahrenheit.
- The pump shall have an integral adjustable timer to change the grease delivery intervals as needed.
- The system shall use a fused electric pump, either 12 Volt DC or 24 Volt DC depending on application. Pneumatic pumps are not acceptable.
- The pump shall be equipped with a pressure relief valve device at the pump outlet to protect the pump from damage due to over pressure.
- For ease of service, the pump shall have a pumping element located on the side that can be removed and replaced or repaired as needed without having to remove or disassemble the pump.
- The pump shall use a clear or translucent reservoir to allow for visual inspection of the grease level. Reservoir shall have a full level indicator. Bladder type reservoirs are not acceptable.
- The grease reservoir shall be a minimum four pound capacity.
- The system shall have a cab mounted fault light that will notify the operator of a lube system fault and low grease level. If any point in the system will not take grease, the fault light shall illuminate.
- The system shall be a positive displacement series progressive type, using primary and secondary valves.
- All secondary valves shall be non-segmented to minimize the potential leak path and or sources of contamination.
- All valves shall be made of corrosion resistant coated carbon steel.
- The positive displacement proportioning valves shall have a tee and high back pressure grease fittings at each valve inlet for manual filling, system testing, and to fill repaired lines.
- The system shall have a manual override fitting to enable the system to be manually operated if the pump is inoperable.
- Equipment shall have a 2 year manufacturer's warranty.

2. Installation Requirements - On Road

- The system shall use only high pressure hose (4,000 psig operating, 10,000 psig burst). All hoses are to be of US standard sizes (1/8" ID hose 5/16 OD) and readily available from local sources.
- All hoses shall use a two piece re-usable hose end with quick disconnects at the valve outlet for ease of inspection and repair.
- All lines from the secondary valves to the chassis or body inlet points shall be flexible with at least a 500 PSI working pressure. All tubing shall be standard size (1/4 inch OD) and readily available from local sources.
- All line runs will be secured to the chassis or air lines via tie wraps. Protective wrap shall be used for all lines run over any edge of the chassis and especially at the termination points for front suspension including upper & lower king pins, tie rod ends and any exposed lines that are not fixed. The use of steel tubing is prohibited.
- The pump shall be installed in a safe location on the truck chassis that is protected and easy to monitor the grease level and refill. For exact mounting location, contact PennDOT Equipment Division, Specification Unit - 717.787.2123
- Ground Level filling shall be provided for all lube systems. Remote lines are acceptable if reservoir is viewable from remote fill location.
- Installations shall be warranted for 2 years of operation.

PA DEPARTMENT OF TRANSPORTATION				
REVISIONS			CENTRALIZED LUBE SYSTEM	
NO.	DATE	BY		
1			SCALE N/A	EQN-501
2			DRAWN BY TOD	
3			DATE 6-8-09	CHK'D BY SHEET 1 OF 2

MINIMUM TYPICAL LUBE POINTS TANDEM AXLE

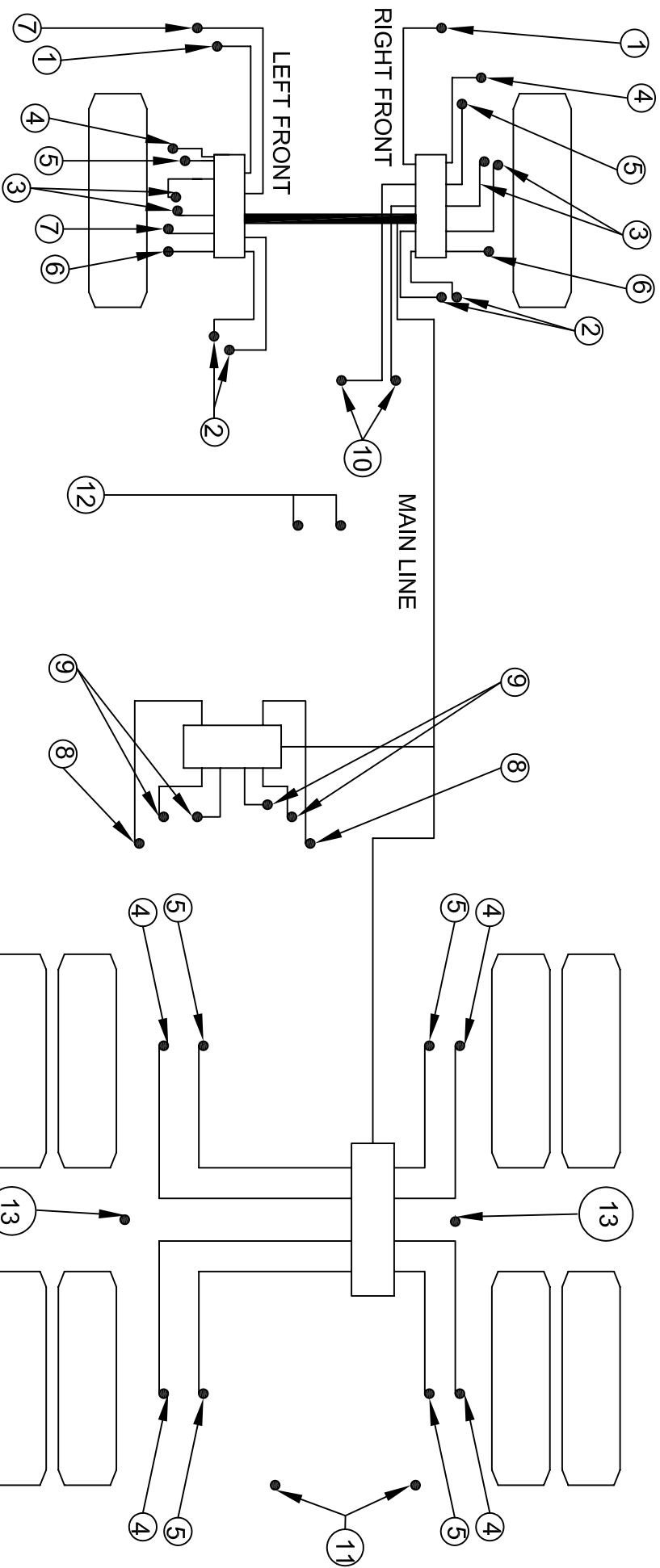

MINIMUM TYPICAL
VEHICLE LUBE POINTS.

*ALL LUBRICATION
POINTS SHALL BE
INCORPORATED INTO
THE ON-BOARD GREASE
SYSTEM. INCLUDING ALL
CHASSIS AND BODY
POINTS, EXCEPT
LOCATIONS RESTRICTED
BY ROTATING DESIGN; IE:
DRIVESHAFT & PTO

1. FRONT SPRING PIN
2. FRONT SPRING SHACKLES
(UPPER AND LOWER)
3. KING PIN (UPPER AND LOWER)
4. BRAKE CAM SHAFT
5. BRAKE SLACK ADJUSTER
6. TIE ROD
7. DRAG LINK
8. FIFTH WHEEL PIVOT (IF APPLICABLE)
9. FIFTH WHEEL PLATE (IF APPLICABLE)
10. CLUTCH CROSS SHAFT
11. REAR DUMP BED HINGE (1 EACH SIDE)
12. TOP AND BOTTOM OF HOIST CYL.

13. DEPENDING ON APPLICATION, ALL REAR SUSPENSION,
TRUIONS, LEAF SPRINGS

PA DEPARTMENT OF TRANSPORTATION

REVISIONS		CENTRALIZED LUBE SYSTEM GENERIC ARRANGEMENT	
NO.	DATE	BY	
1	12-15-00	GAH	
2	01-02-07	CJW	
3	06-09-09	TOD	
4			
5			

REVISIONS		CENTRALIZED LUBE SYSTEM GENERIC ARRANGEMENT	
NO.	DATE	BY	
1	12-15-00	GAH	
2	01-02-07	CJW	
3	06-09-09	TOD	
4			
5			

ITEM NUMBER	DESCRIPTION	TRUCK REAR LB.	TRUCK REAR KG.	TRUCK FRONT LB.	TRUCK FRONT KG.	TOTAL LB. OR KG.
1.	CHASSIS WEIGHT					
2.	DIESEL FUEL					
3.	DRIVER					200 lb.
4.	BODY					
5.	BODY HOIST					
6.	SPREADER					
7.	PLOW FRAME					
8.	SNOW PLOW					*
9.	FRONT PTO, ADAPTER & PUMP					
10.	PAYLOAD					
11.	HYDRAULIC OIL & TANK					
12.	PATROL STYLE WING PLOW					
13.	FRONT WING POST (PATROL)					
14.	REAR WING POST (PATROL)					
15.	PREWET TANK ___ GALLON					

NOTES:

- (1) THE INFO. SHALL BE SUBMITTED IN ITS ENTIRETY & SUBMITTED WITH BID.
- (2) ALL THE ACCESSORIES REQUIRED TO BE "FULLY OPERATIONAL" MUST BE INCLUDED IN THE CALCULATION OF WEIGHTS, AS APPLICABLE.
- (3) FOR INFORMATION:

MATERIAL WEIGHTS:

SALT 2,000 lb. PER CUBIC YARD
 AGGREGATE 2,800 lb. PER CUBIC YARD
 TYPE II = 2,900 lb. TYPE IV = 3,500 lb.

PA DEPARTMENT OF TRANSPORTATION

REVISIONS

NO.	DATE	BY	MINIMUM TRUCK WEIGHT DISTRIBUTION	MINIMUM DATA REQUIRED
1	05-16-07	KNH		
2	07-20-09	TOD		
3	07-24-18	KBD		

DUMP TRUCK WEIGHT DISTRIBUTION

DRAWN BY	SCALE	DATE	CHRG BY
DLW	N/A	07-14-97	WHM

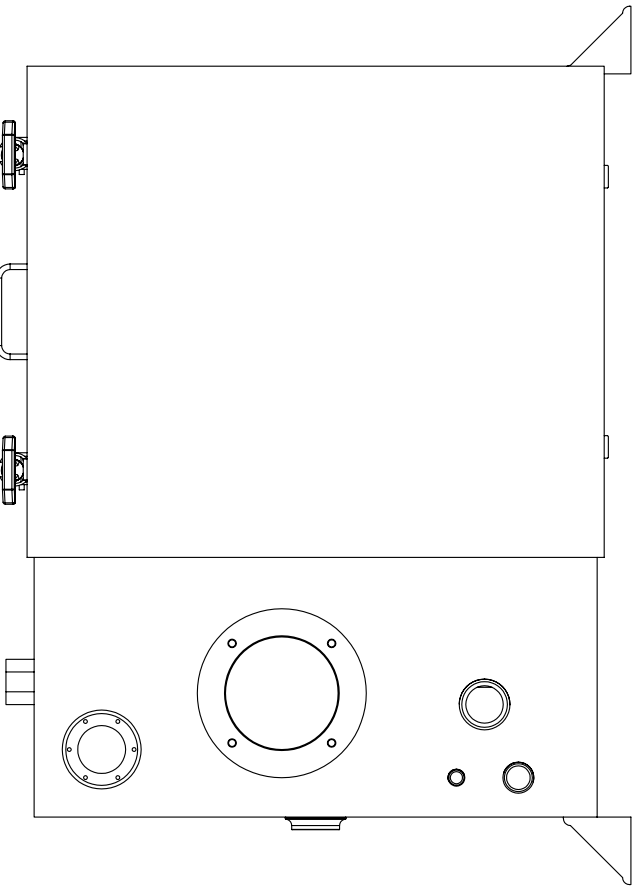
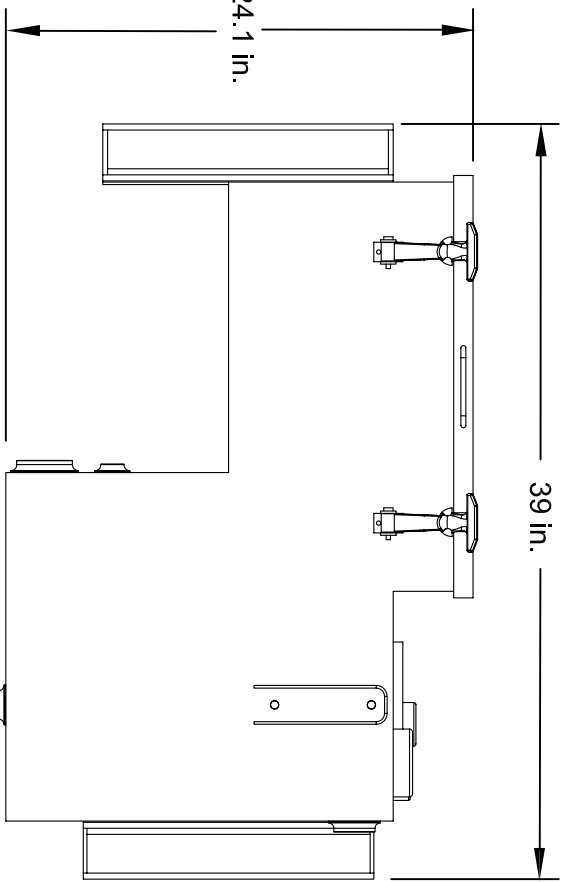
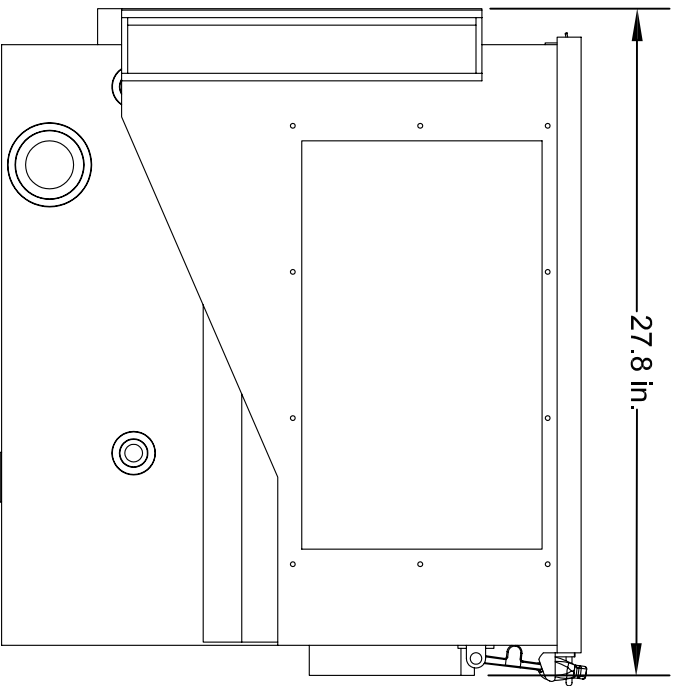

PA DEPARTMENT OF TRANSPORTATION

REVISIONS			DUMP TRUCK VALVE ENCLOSURE / TANK COMBO		
NO.	DATE	BY	DRAWN BY	SCALE	EQN-508
1			TOD	N/A	
2					
3					

DRAWN BY: TOD
 DATE: 11-03-09
 SCALE: N/A
 CHECKED BY: DMA
 SHEET 1 OF 1

NOTE: SPREADER CONTROL BASE SHALL BE PROPERLY BRACED TO ELIMINATE FLOOR FLEX. ADDITIONAL SUPPORT BRACKET SHALL BE VENDORS RESPONSIBILITY.

ADDITIONAL SUPPORT BRACKETS SHALL BE USED TO ELIMINATE CONSOLE VIBRATION. SPREADER CONTROL BASE SHALL BE PROPERLY POSITIONED TO ELIMINATE FLOOR FLEX. CAB FLOOR SHALL BE REINFORCED TO ELIMINATE FLEX. ADDITIONAL SUPPORT BRACKETS AND REINFORCEMENTS SHALL BE VENDORS RESPONSIBILITY.

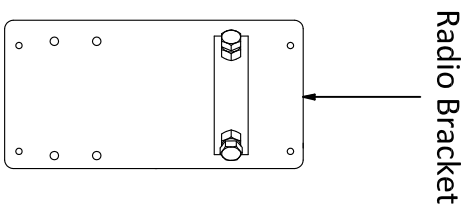
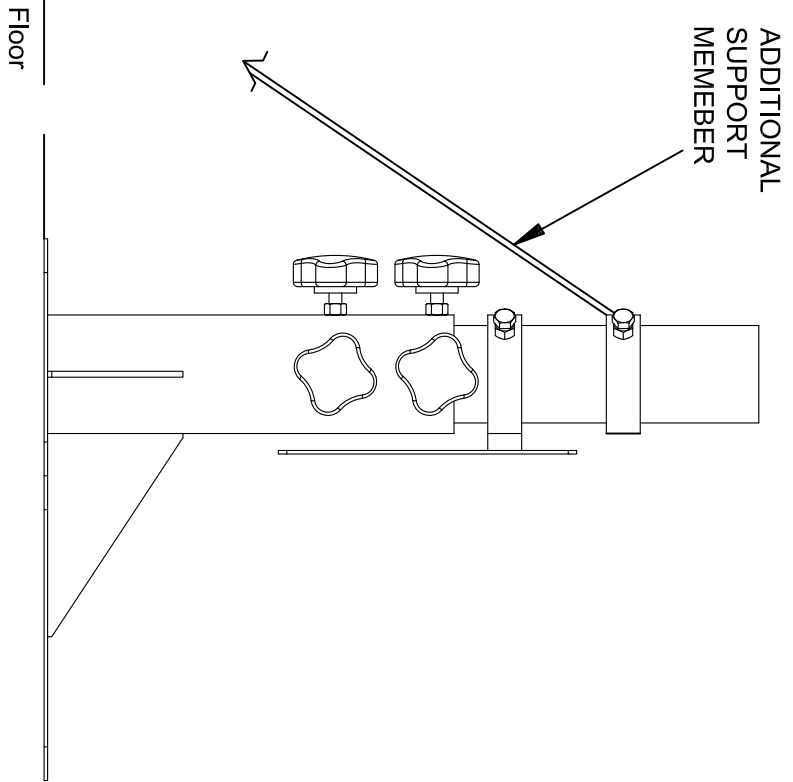
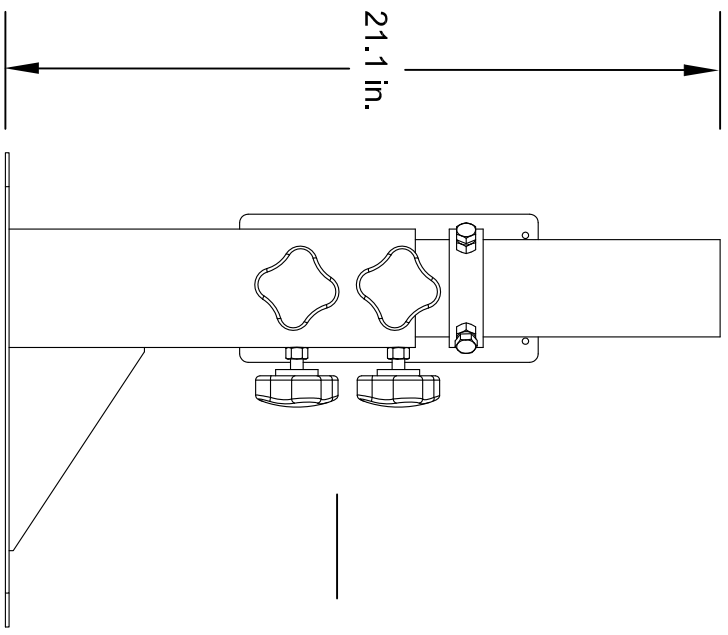
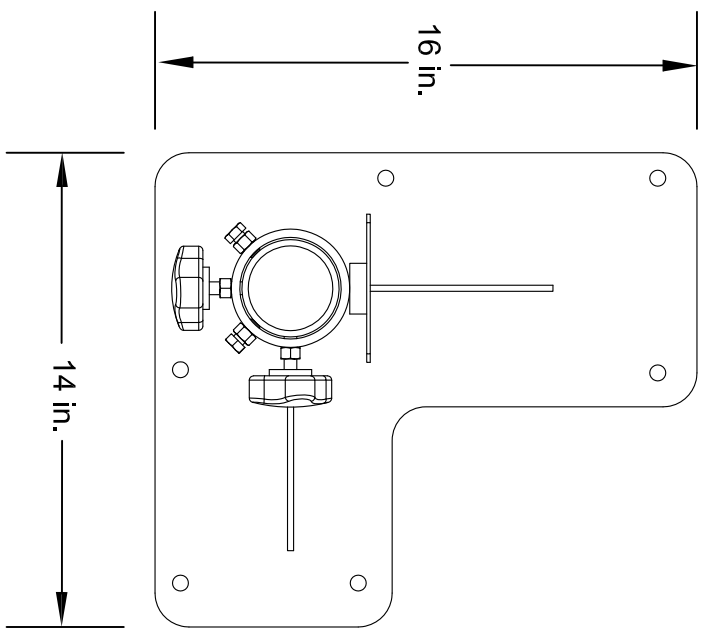

PA DEPARTMENT OF TRANSPORTATION

REVISIONS		DUMP TRUCK SPREADER CONTROL BASE WITH RADIO BRACKET	
NO.	DATE	BY	
1	8-01-18	KBD	
2			
3			

DRAWN BY	TOD	SCALE	N/A	EQN-509
DATE	11-03-09	CHRG BY	DMA	SHEET 1 OF 1

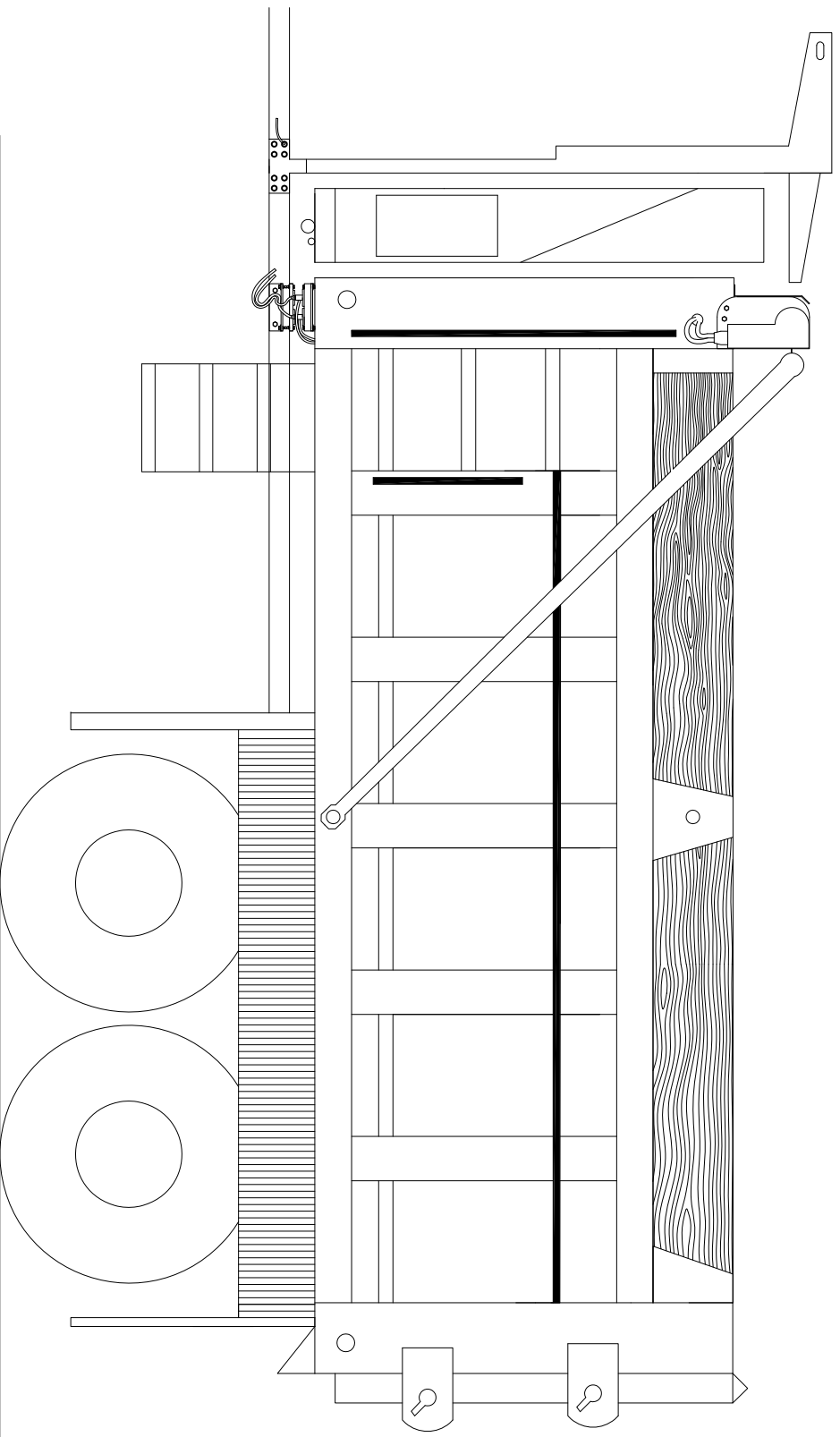

SCALED BY 5

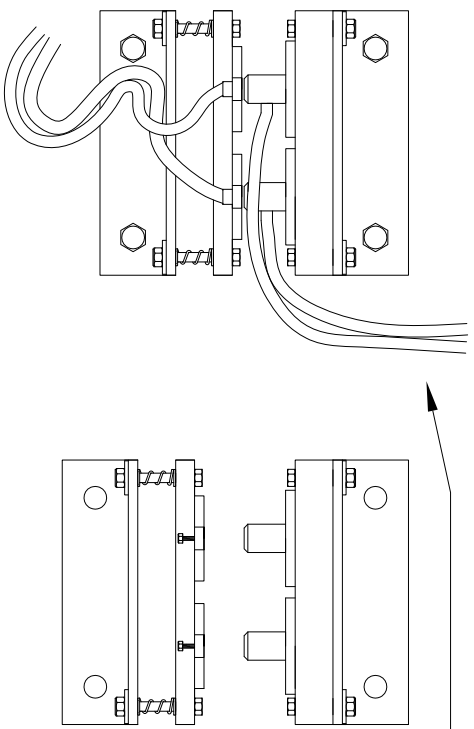

PA DEPARTMENT OF TRANSPORTATION

WIRELESS CONNECT AND TARP

REVISIONS			DRAWN BY			SCALE		
NO	DATE	BY	DATE	CHK'D BY		DATE	CHK'D BY	
1	00-00-00	INT			JFM	N/A		EQN 550
2								
3								

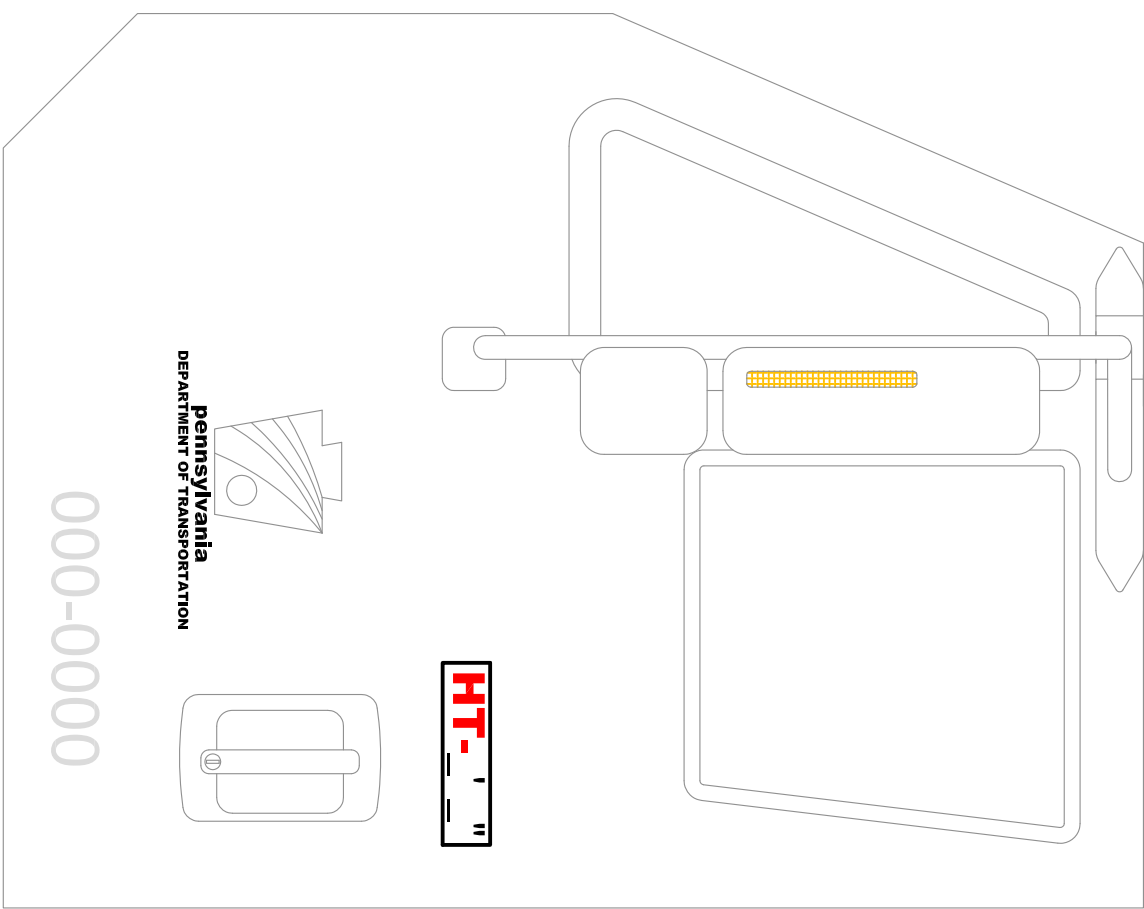

THERE SHALL BE A PERMANENT DECAL, 2 INCH HIGH RED LETTERS ON WHITE BACKGROUND AFFIXED BY THE DRIVER SIDE DOOR HANDLE OR OPERATOR STATION STATING THE OVERALL MAXIMUM TRAVEL HEIGHT OF THE COMPLETED AND UNLOADED UNIT.

PA DEPARTMENT OF TRANSPORTATION REVISIONS			MAX TRAVEL HEIGHT STICKER		
NO.	DATE	BY	DRAWN BY	Checked With	
1	07-06-17	HMR	JFM		EQN-552
2	07-25-18	KBD			
3					

000-0000

pennsylvania
DEPARTMENT OF TRANSPORTATION

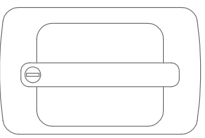
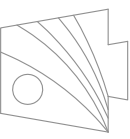

HT-1"

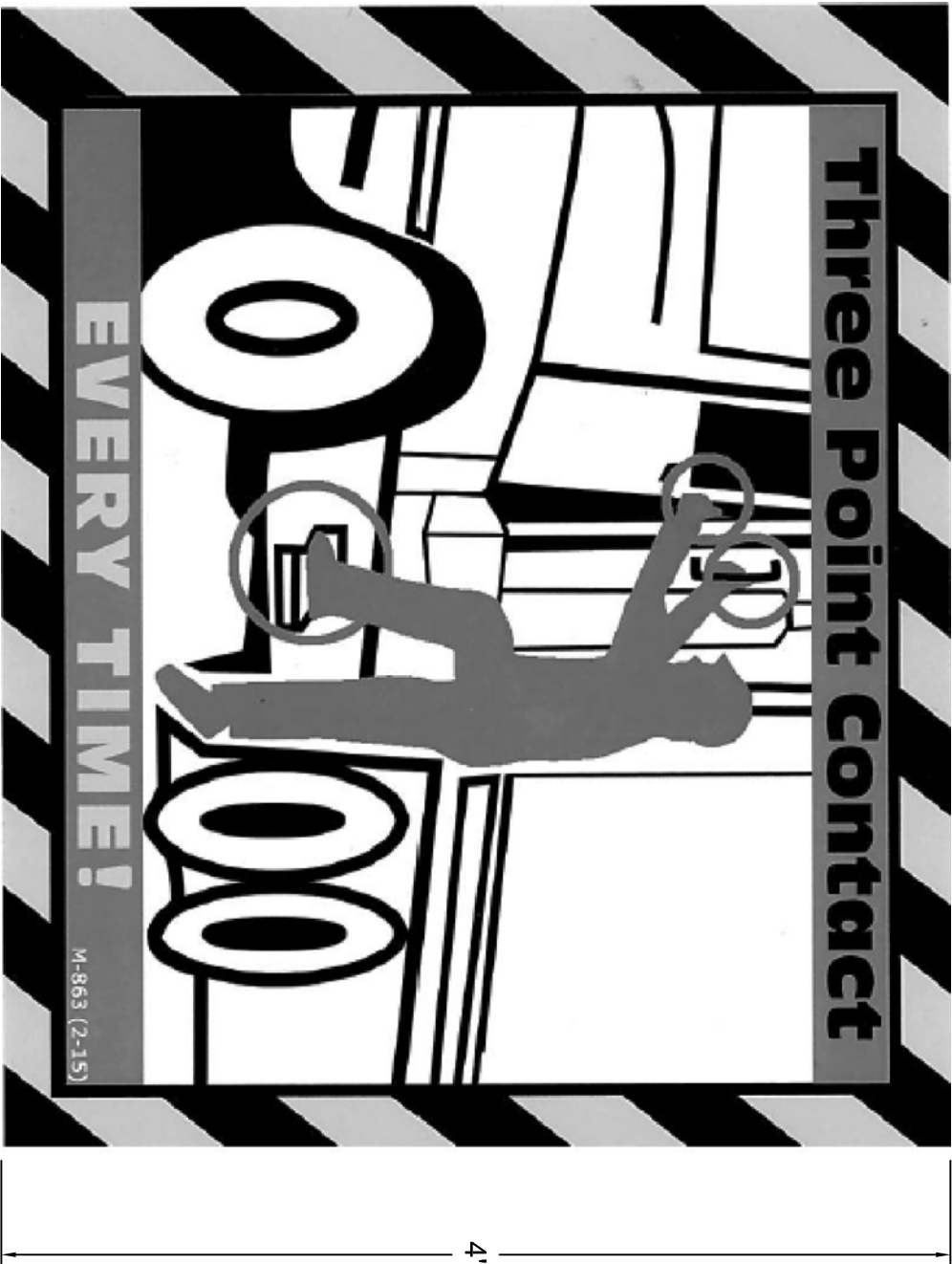

THERE SHALL BE A PERMANENT DECAL AFFIXED BY EACH ENTRY POINT. THE SAME PERMANENT DECAL SHALL BE AFFIXED BY EACH LADDER, PLATFORM OR STEP DESIGNED TO BE CLIMBED OR STEPPED ON. MEASUREMENTS OF DECAL ARE REFERENCED ABOVE.

PA DEPARTMENT OF TRANSPORTATION

REVISIONS		THREE POINTS OF CONTACT STICKER	
NO	DATE	BY	
1	12-20-16	JJB	
2	07-06-17	HMR	
3			

DATE	03-23-15	SCALE	N/A	EQN-552-1
DRAWN BY	GAW	CHG'D BY	TOD	SHEET 1 OF 1

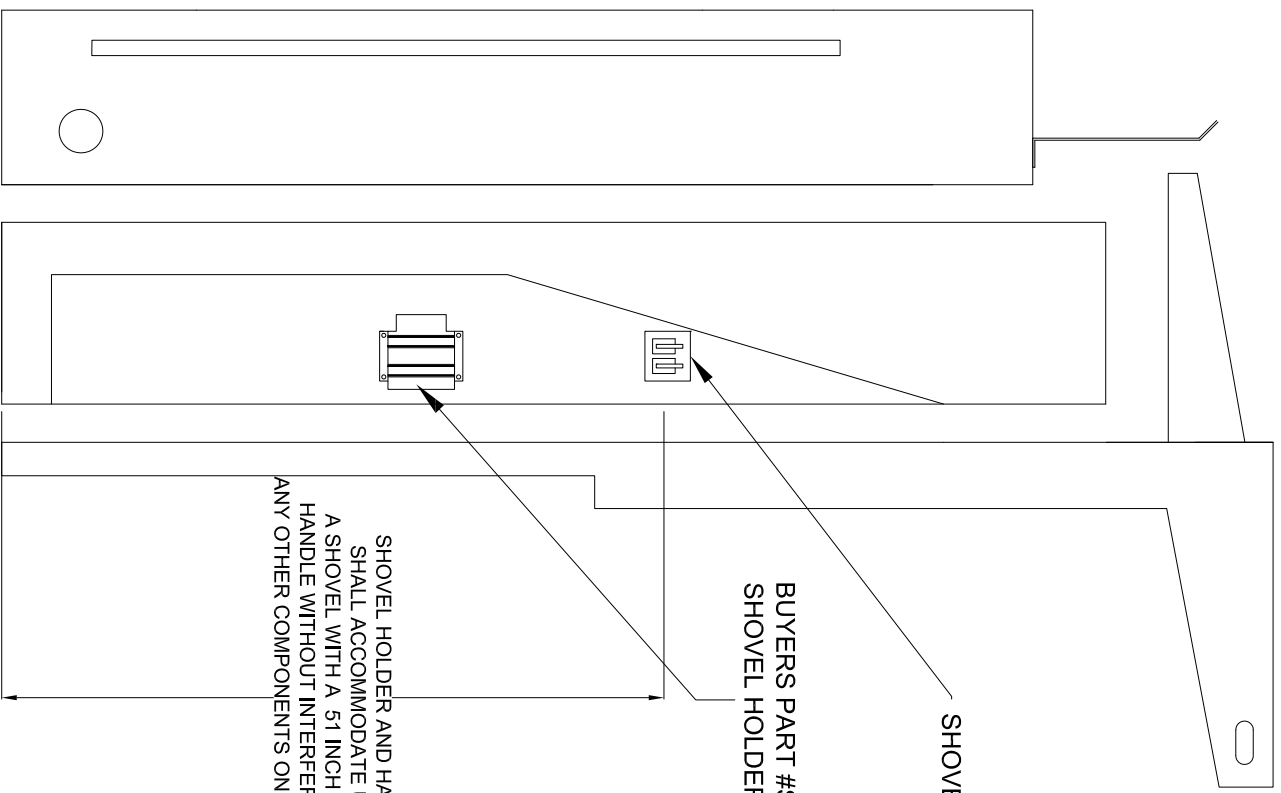

SHOVEL HOLDER HOOKS

BUYERS PART #SH675SS
SHOVEL HOLDER

SHOVEL HOLDER AND HANGER
SHALL ACCOMMODATE UP TO
A SHOVEL WITH A 51 INCH LENGTH
HANDLE WITHOUT INTERFERING WITH
ANY OTHER COMPONENTS ON THE TRUCK.

PA DEPARTMENT OF TRANSPORTATION

SHOVEL HOLDER

REVISIONS

NO.	DATE	BY
1	00-00-00	INT
2		
3		

DRAWN BY		JFM	SCALE	2.2	EQN-557
DATE		05-20-13	CHK'D BY	INT	SHEET 1 OF 1

TAILGATE

FOR CONSPICUITY STRIPING, REFER TO EQN-122

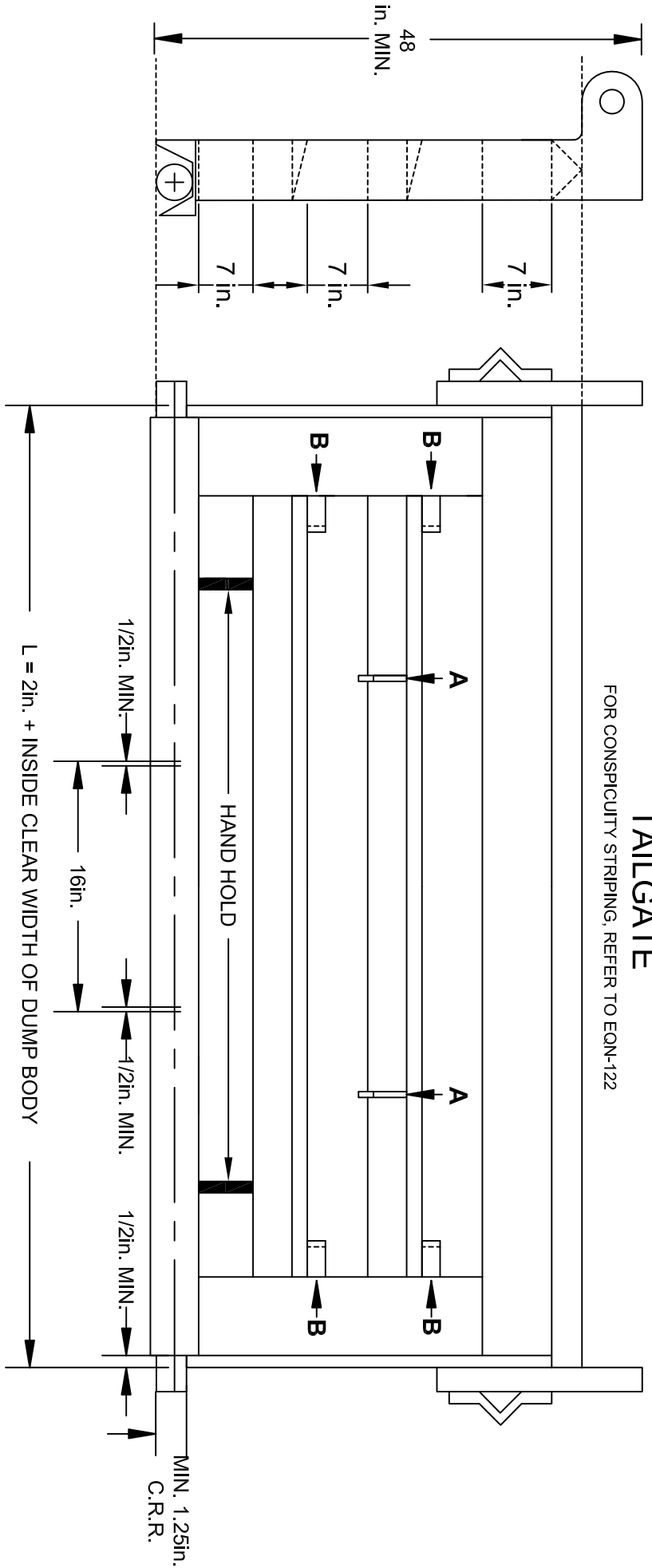

- NOTES:**
- A. THERE SHALL BE 2 "J" HOOKS PER TAILGATE AND SHALL BE FULLY WELDED AS CHAIN HOLDERS.
 - B. THERE SHALL BE 4 TAILGATE CHAIN BRACKETS FULLY WELDED TO THE TAILGATE.
 - HORIZONTAL CROSS-MEMBER ABOVE THE DOOR SHALL BE ONE CONTINUOUS RUN ACROSS TAILGATE.
 - COMPLETE TAILGATE SHALL BE TYPE 304 STAINLESS STEEL.

PA DEPARTMENT OF TRANSPORTATION

REVISIONS			TAILGATE		
NO.	DATE	BY			
1					
2					
3					

DRAWN BY	JFM	SCALE	N/A	EQN-561
DATE	01-06-14	CHK'D BY	RED	SHEET 1 OF 1

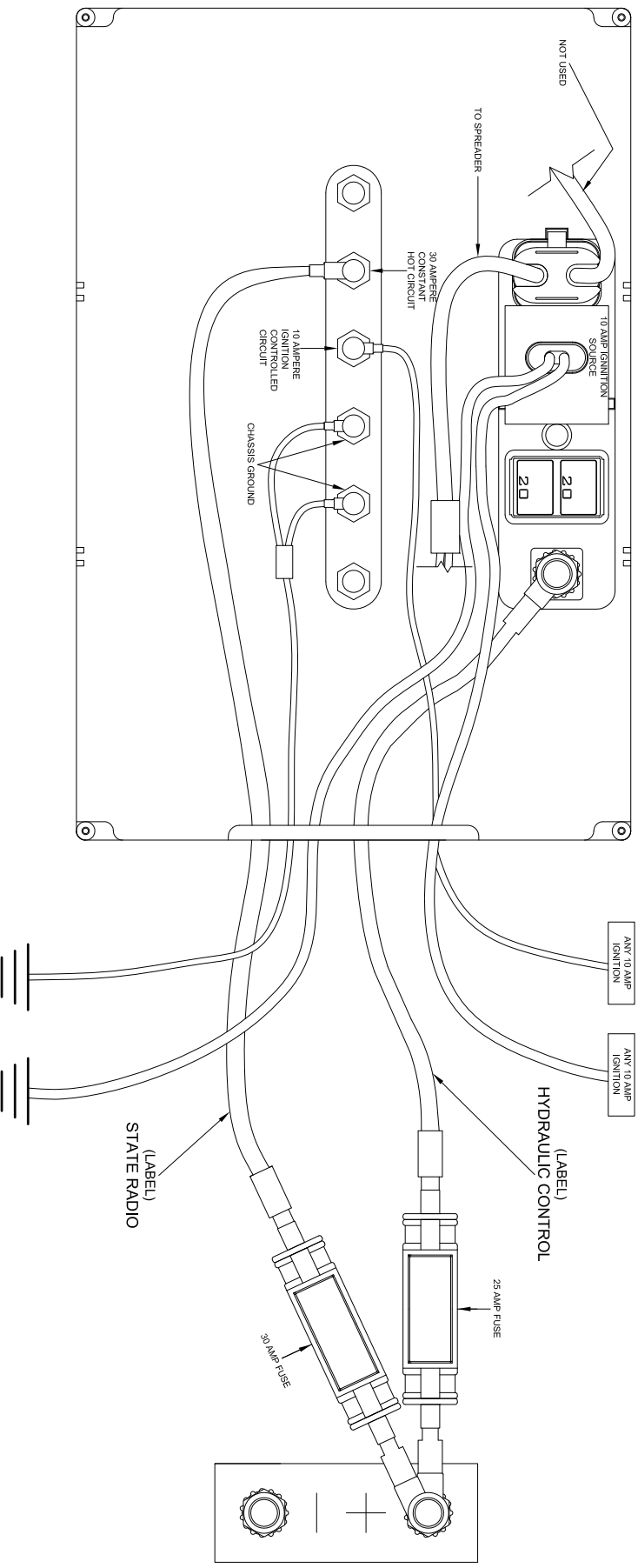

NOTE:

EACH CIRCUIT SHALL BE SUPPLIED INDIVIDUALLY, LABELED, PROPERLY SIZED, PROTECTED FROM WEATHER, AND SEALED TO BE WATERTIGHT.

PA DEPARTMENT OF TRANSPORTATION

POWER DISTRIBUTION BOX FOR STATE RADIO AND SPREADER CONTROLS

NO.	DATE	BY	REVISIONS
1	00-00-00	INT	
2			
3			

DATE	01-08-14	CHK'D BY	INT	SHEET	1 OF 1
DRAWN BY	JFM	SCALE	N/A	EQN-562	

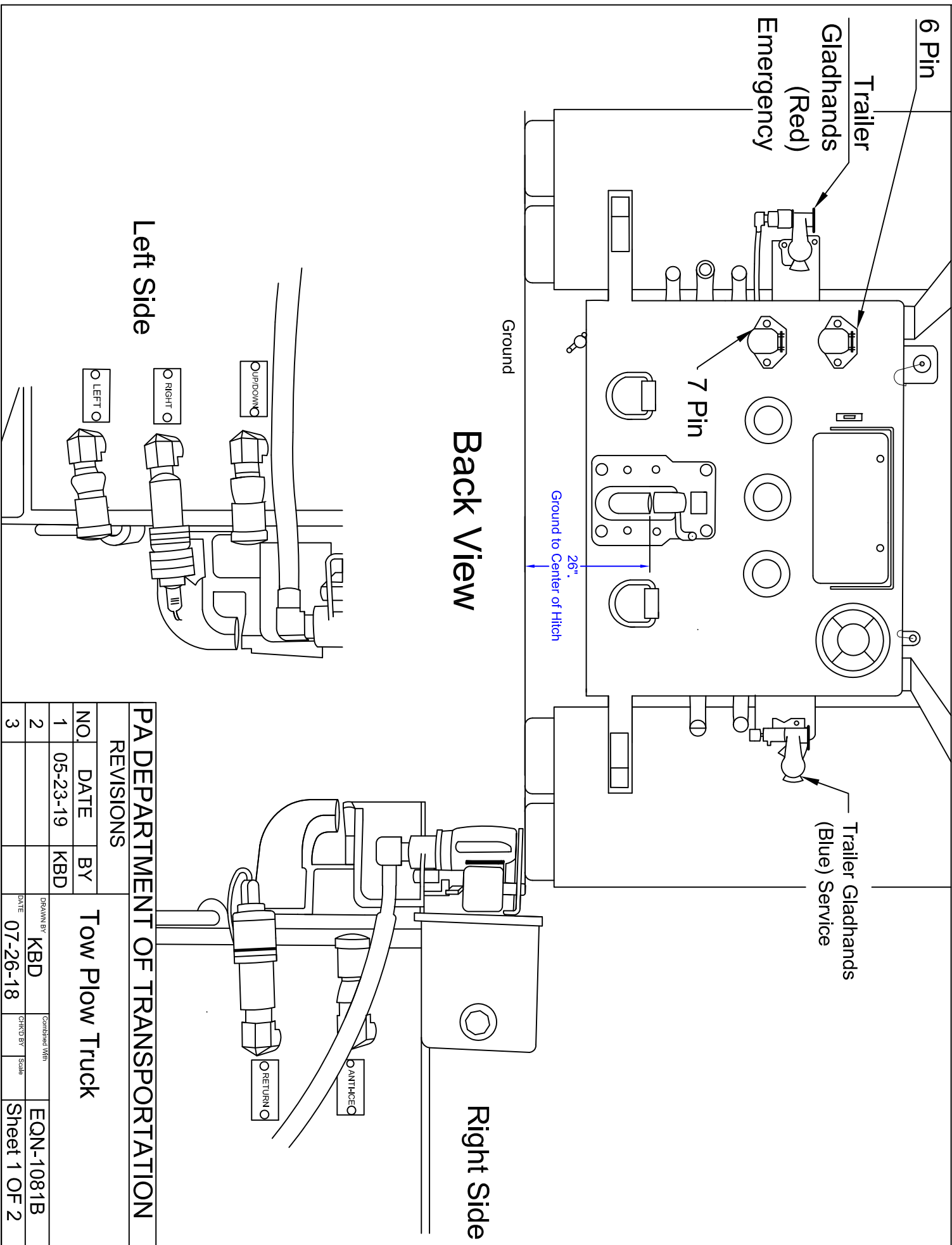

PA DEPARTMENT OF TRANSPORTATION

REVISIONS

NO	DATE	BY	DESCRIPTION
1	05-23-19	KBD	
2			
3			

Tow Plow Truck

DRAWN BY	KBD	Checked With	EQN-1081B
DATE	07-26-18	CHG'D BY	Scale
			Sheet 1 OF 2

NOTES:

- VIEW OF FEMALE CONNECTOR, STANDING AT REAR OF TRUCK, LOOKING AT THE CONNECTOR.
- BRAKE LIGHTS SHALL FUNCTION WITH TURN SIGNALS.
- WIRE SHALL BE 6 WAY (1-10 GAUGE; 6-12 GAUGE) PER ATA COLOR CODE, CLAMPED EVERY 18" MINIMUM.
- CONNECTION SHALL BE MADE USING FACTORY OEM TRAILER WIRING HARNESS.
- ALL CONNECTIONS SHALL BE WATER TIGHT.
- ALL PINS SHALL BE ROUND STYLE.

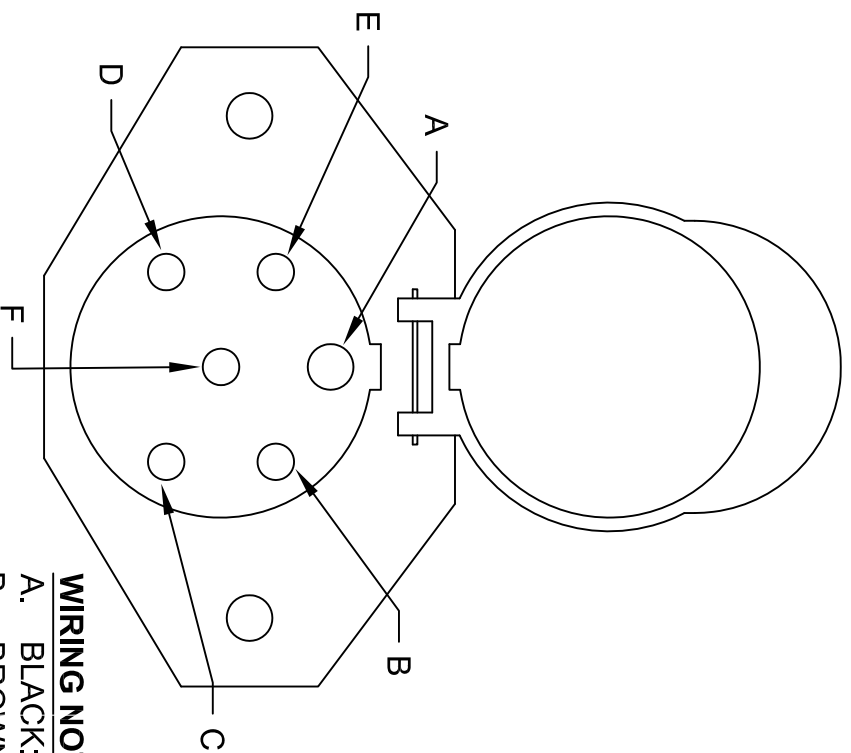

WIRING NOTES:

- A. BLACK: BEACON - 12
- B. BROWN: WING LIGHT -12
- C. GREEN: ---
- D. YELLOW: SIDE STROBE -12
- E. WHITE: GROUND - 10
- F. RED: UPPER REDS - 12

WIRES NEED TO EXTEND 8ft. BEYOND PINTLE.

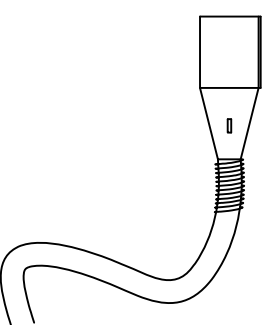

WIRING NOTES:

- A. BLACK: BEACON - 10
- B. BROWN: WING LIGHT - 12
- C. GREEN: ---
- D. YELLOW: SIDE STROBE - 12
- E. WHITE: GROUND - 12
- F. RED: UPPER REDS - 12

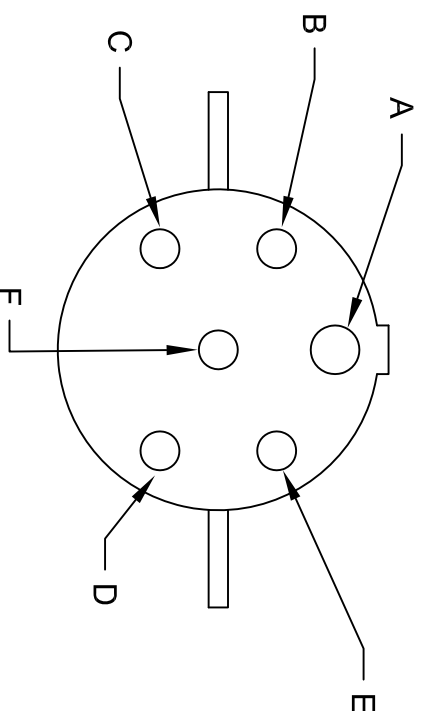

PA DEPARTMENT OF TRANSPORTATION

REVISIONS

NO.	DATE	BY	DESCRIPTION
1	08-02-18	KBD	
2	05-23-19	KBD	
3			

Tow Plow Truck Wiring

DRAWN BY	JJB	Checked With	
DATE	08-02-16	CHKD BY	Scale
			EQN-1081B
			SHEET 2 OF 2

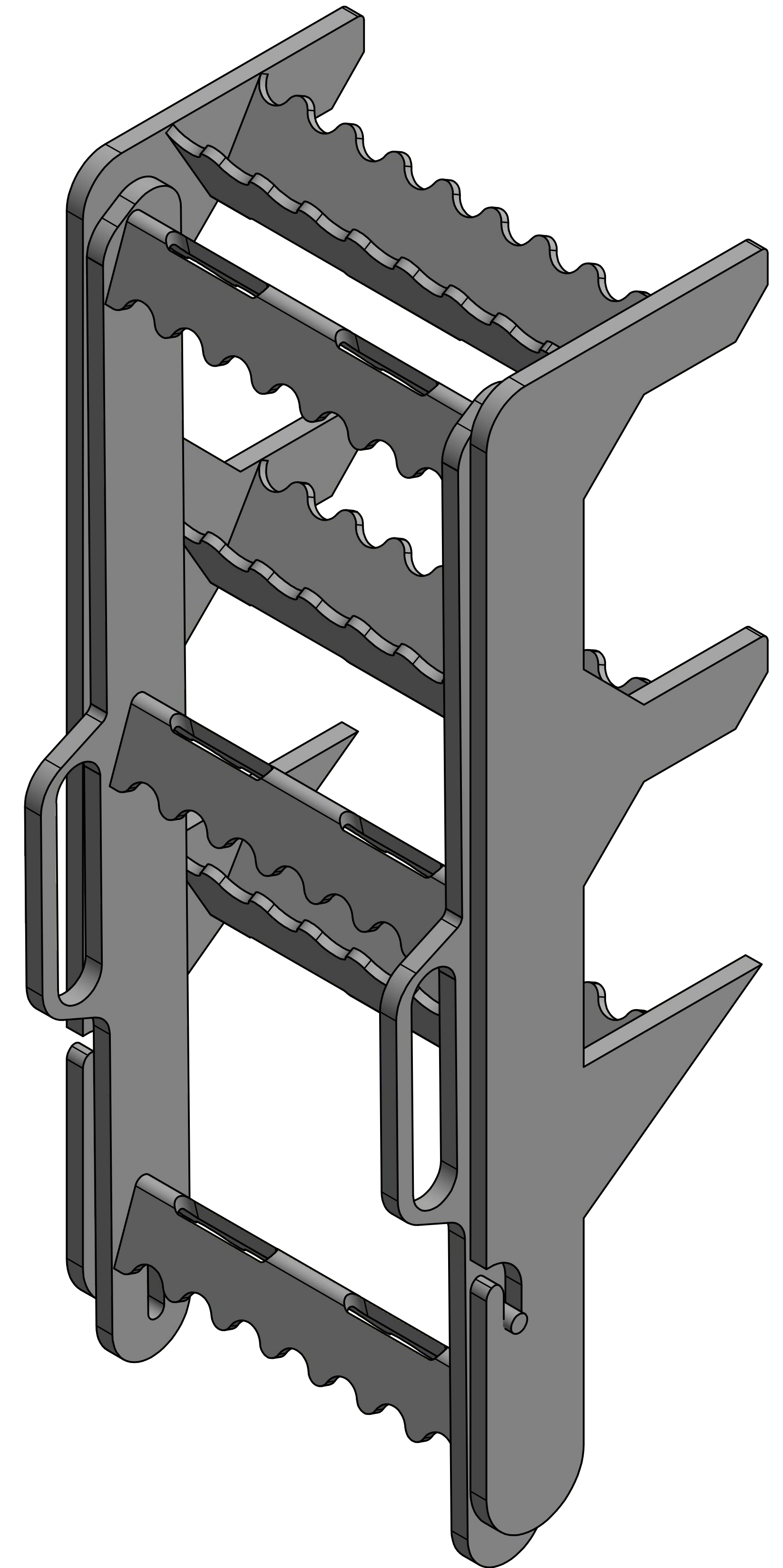
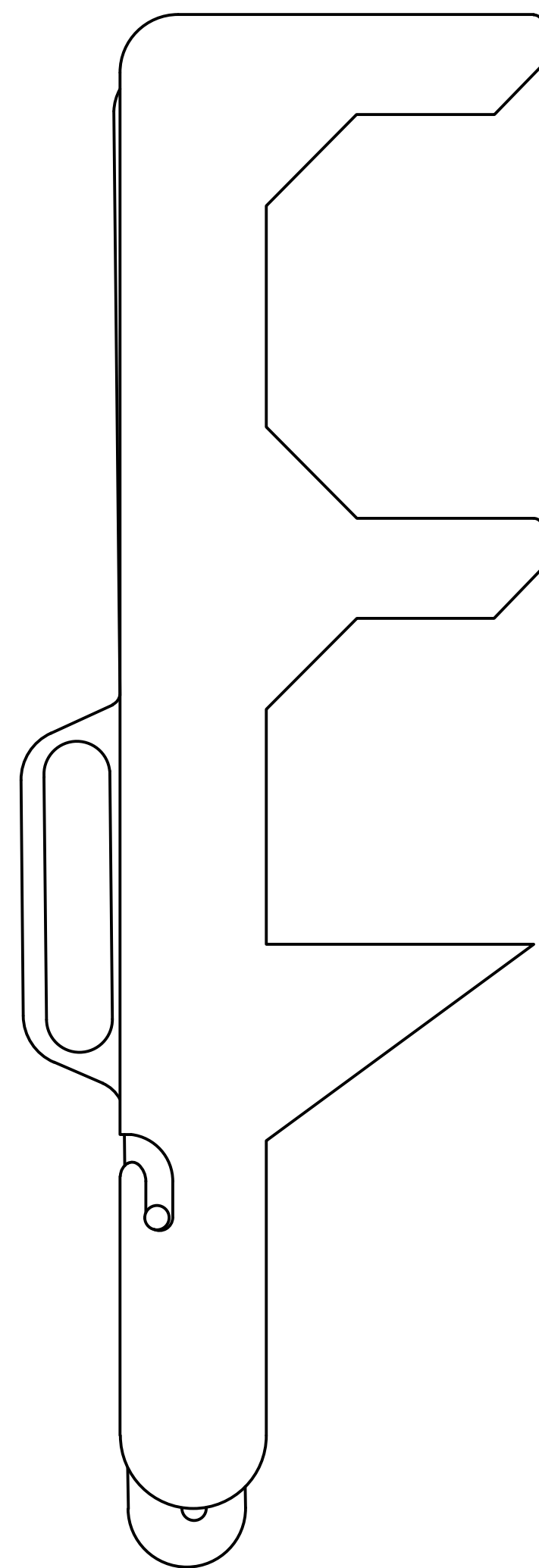
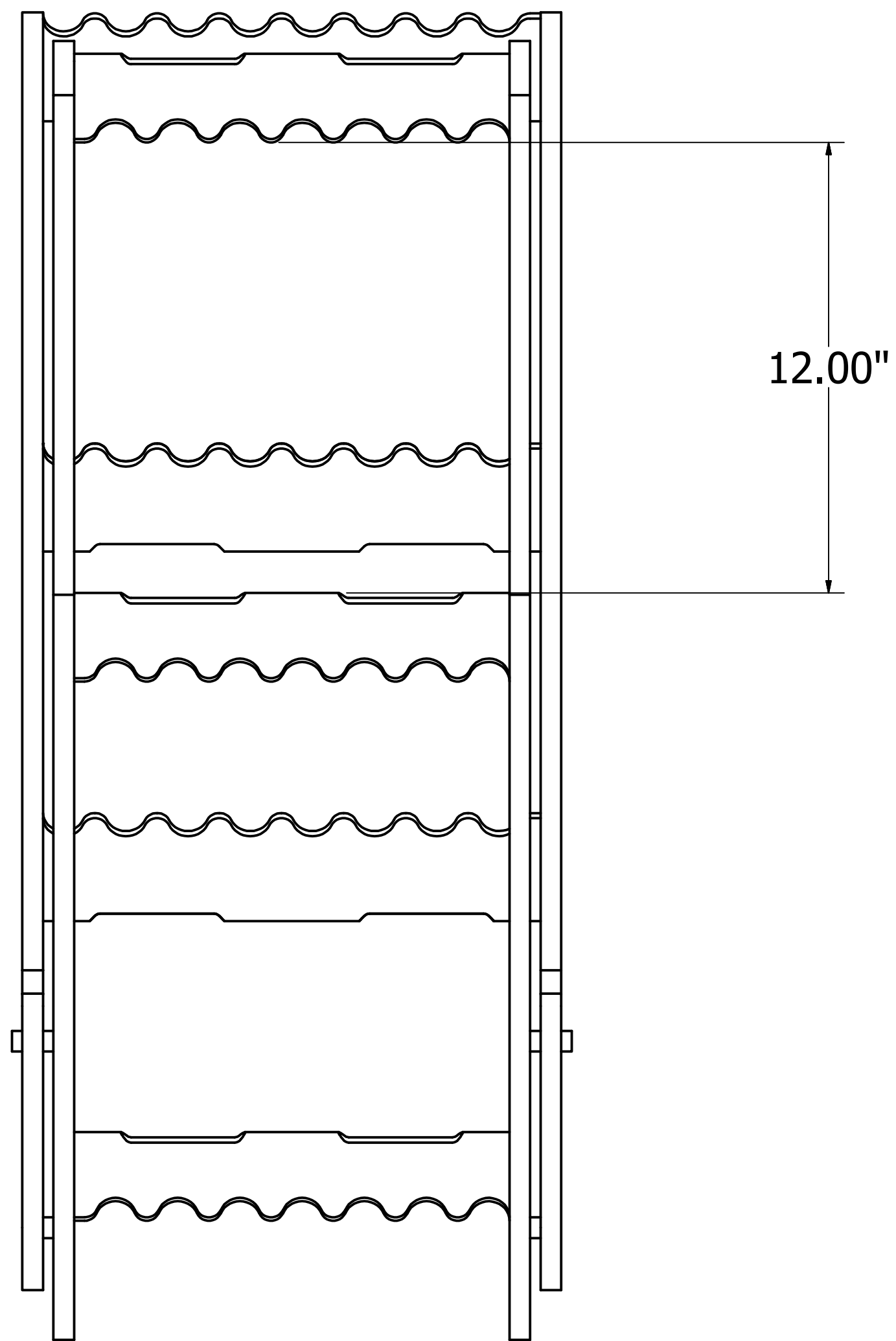
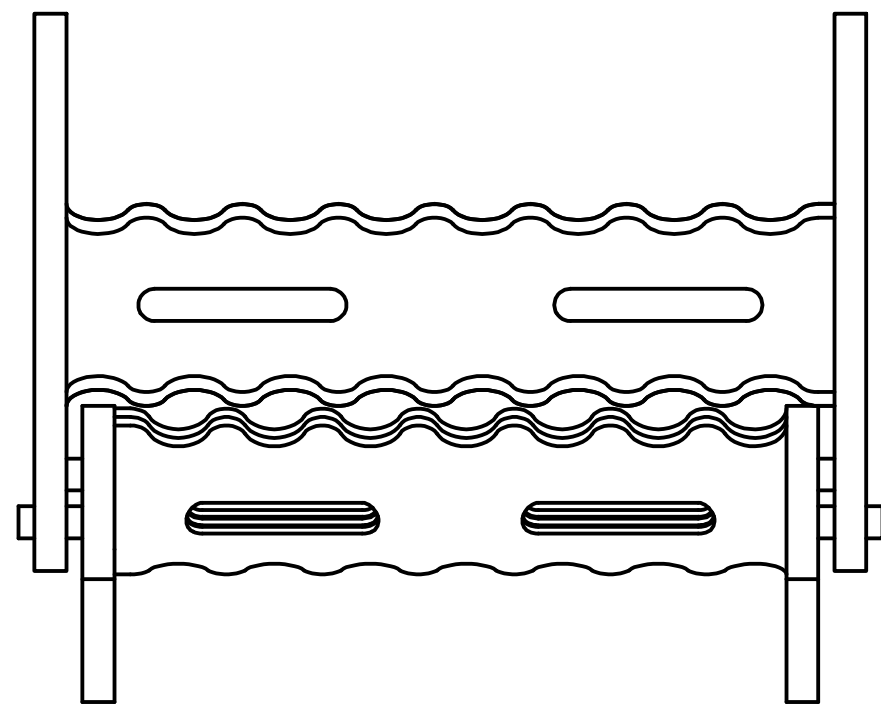

PA DEPARTMENT OF TRANSPORTATION					
REVISIONS			FLIP STEP		
NO.	DATE	BY			
1					
2			DRAWN BY	Combined With	EQN-1090
3			DATE	CHKD BY	Scale
			07-26-19		
					SHEET 1 OF 3

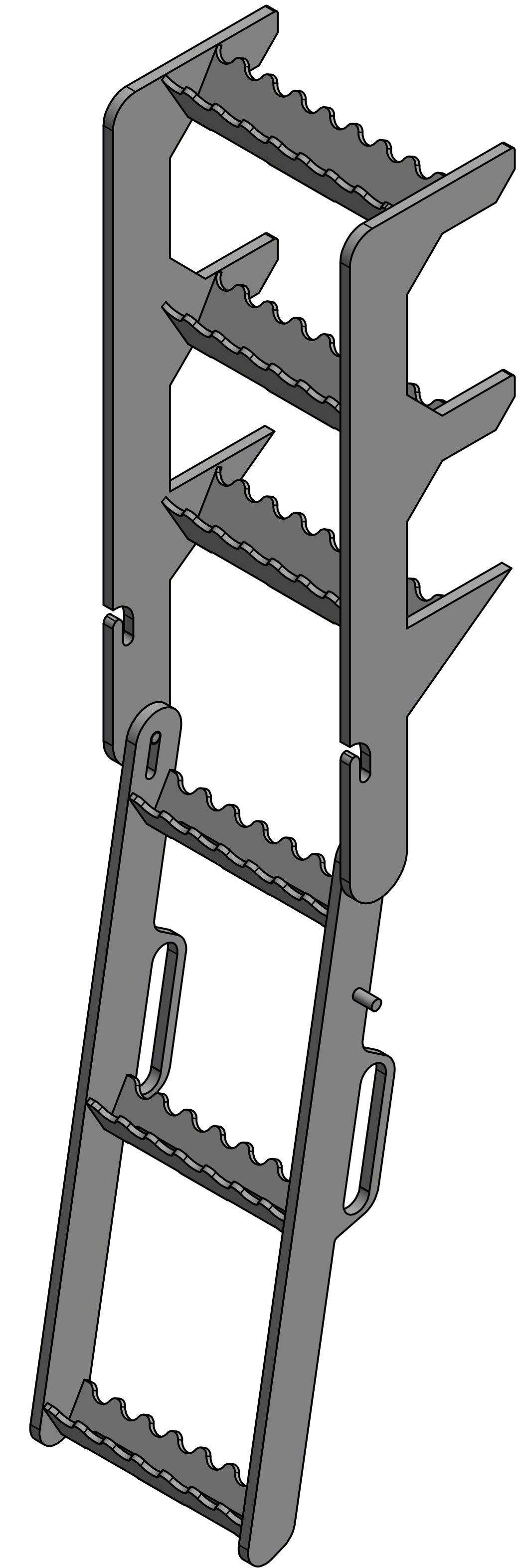
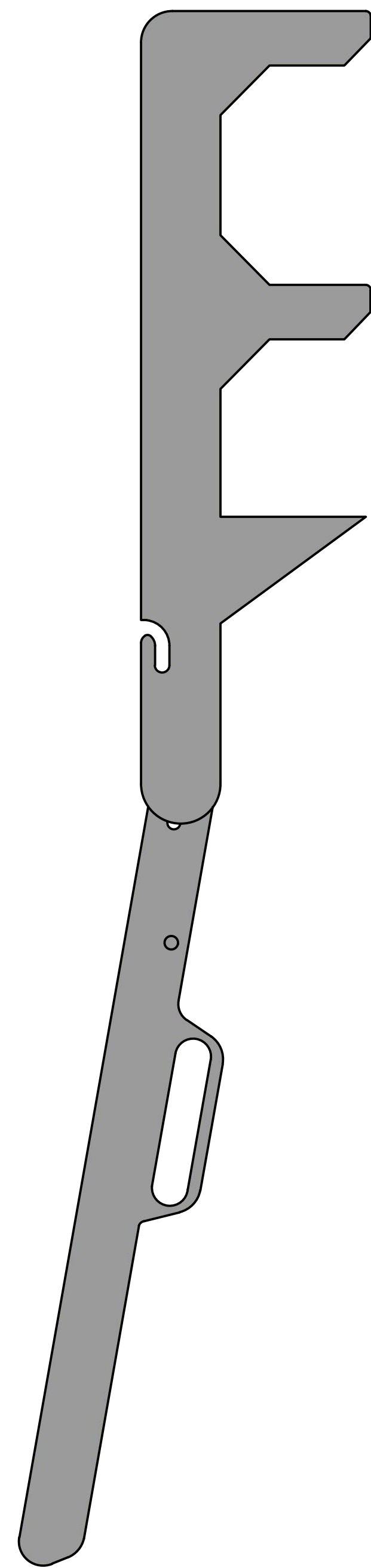
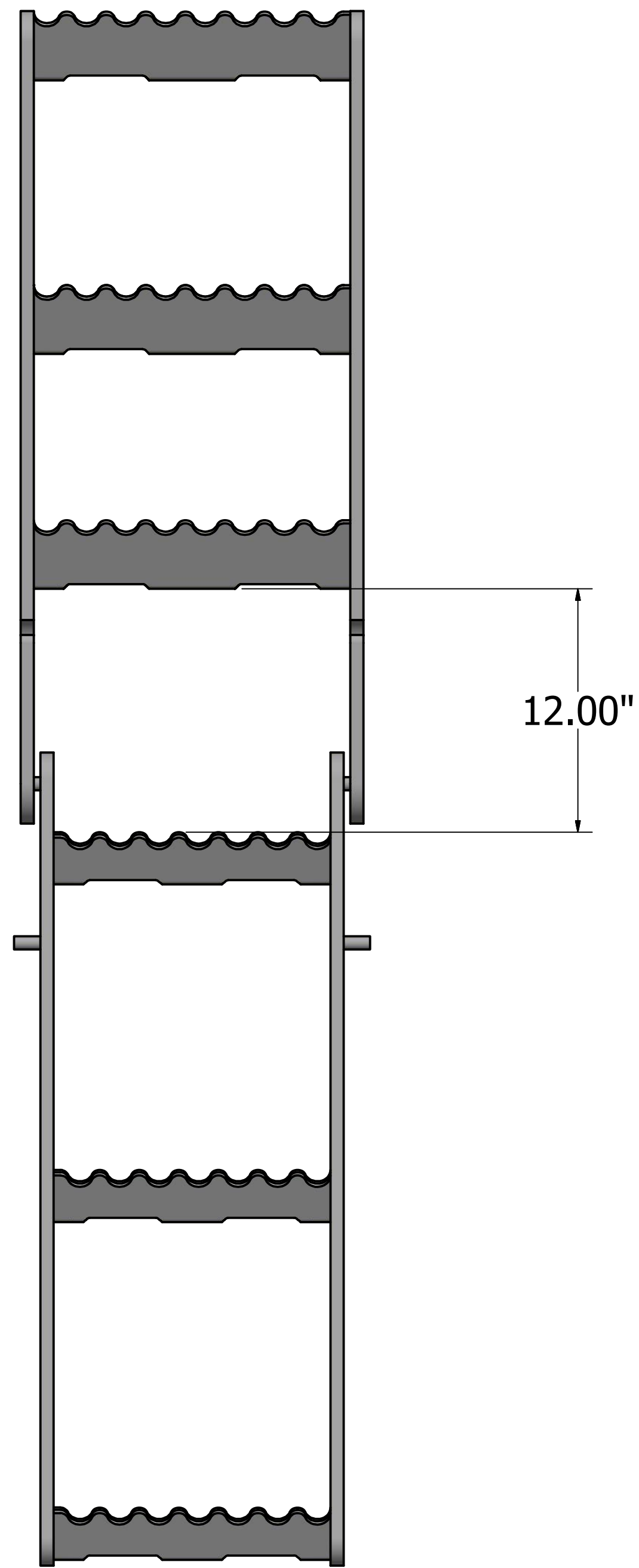
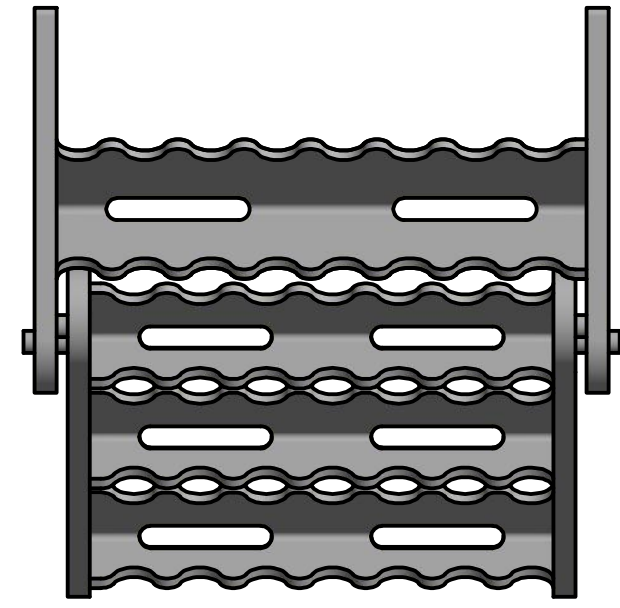

PA DEPARTMENT OF TRANSPORTATION

REVISIONS			FLIP STEP		
NO.	DATE	BY			
1					
2			<small>DRAWN BY</small> KBD	<small>Combined With</small>	EQN-1090
3			<small>DATE</small> 07-26-19	<small>CHK'D BY</small> Scale	SHEET 2 OF 3

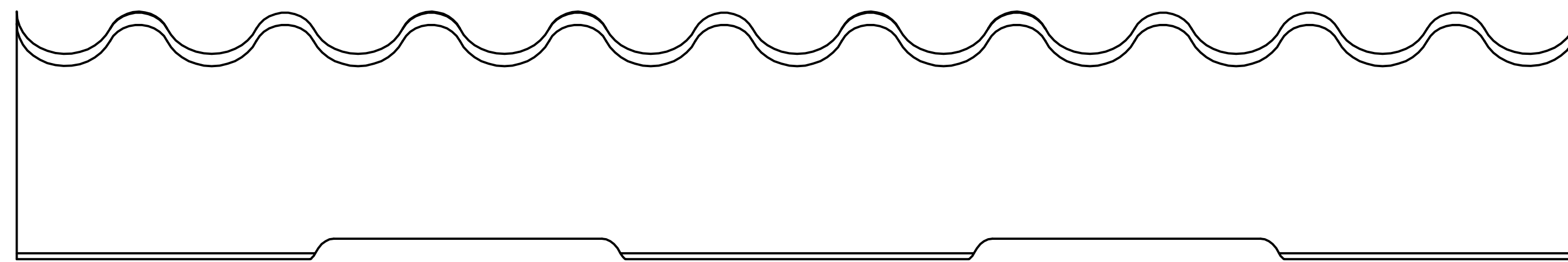
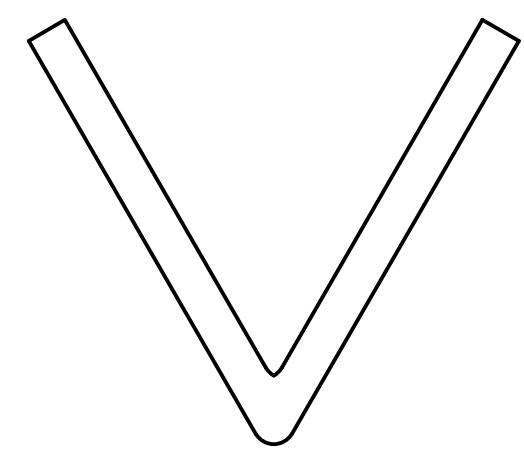
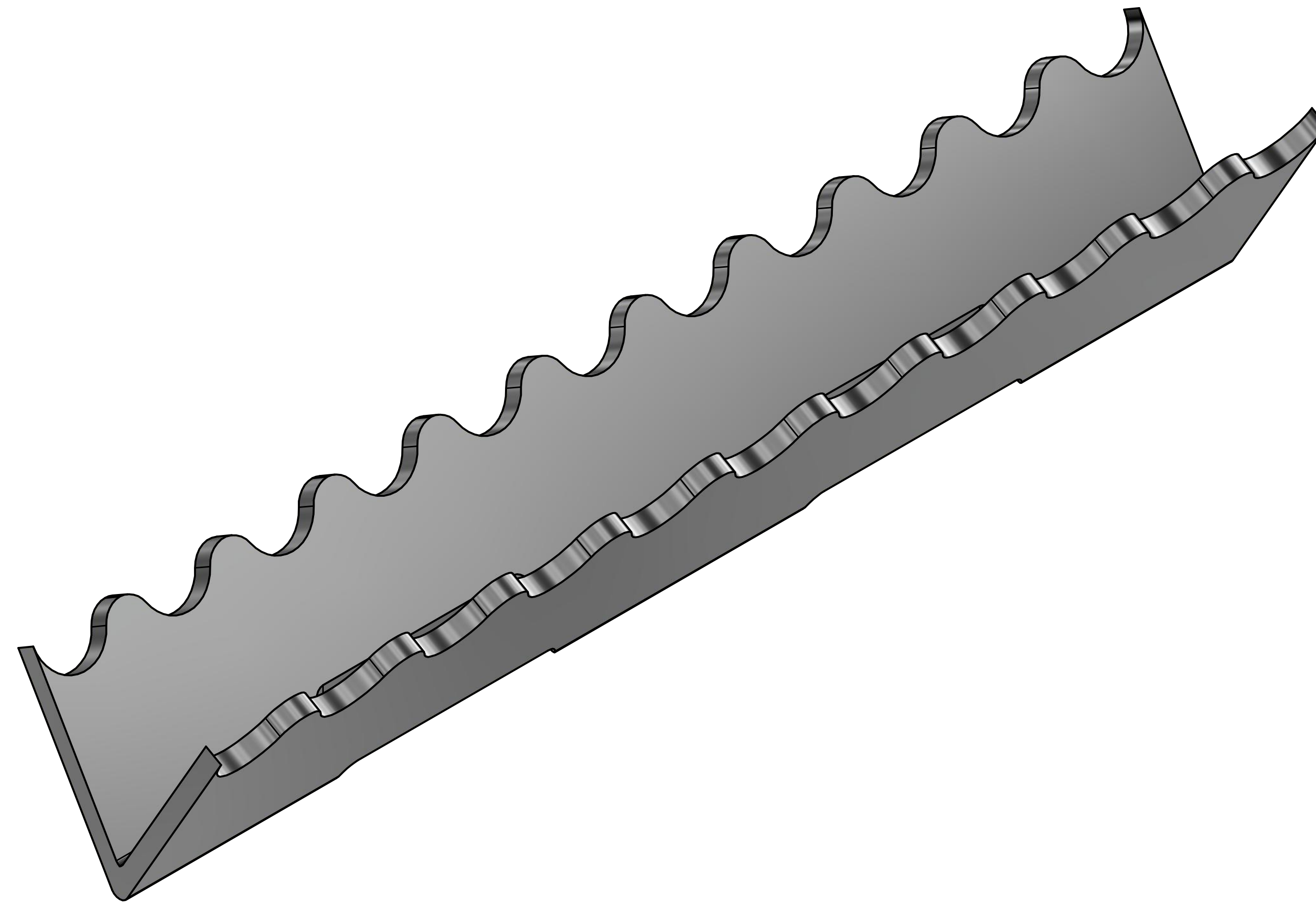
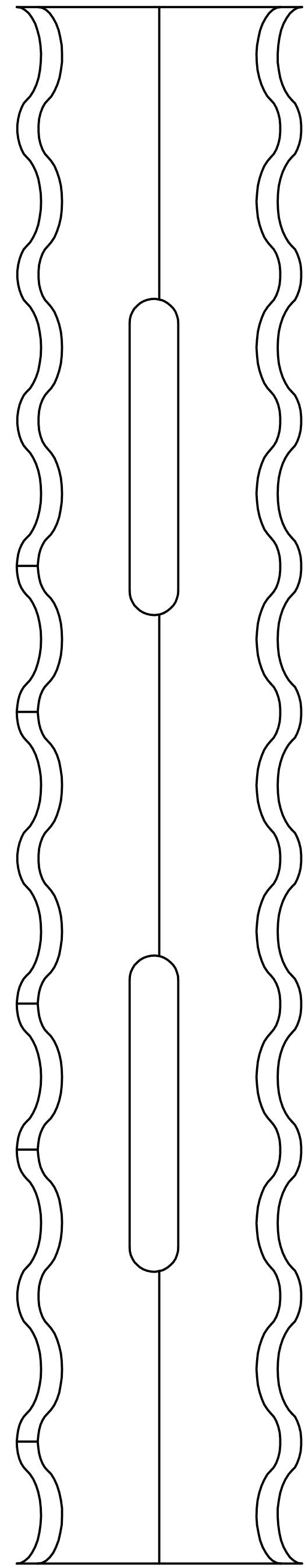

PA DEPARTMENT OF TRANSPORTATION					
REVISIONS			FLIP LADDER STEPS DESIGN		
NO.	DATE	BY			
1					
2			<small>DRAWN BY</small> KBD	<small>Combined With</small>	EQN-1090
3			<small>DATE</small> 07-26-19	<small>CHKD BY</small>	<small>Scale</small>

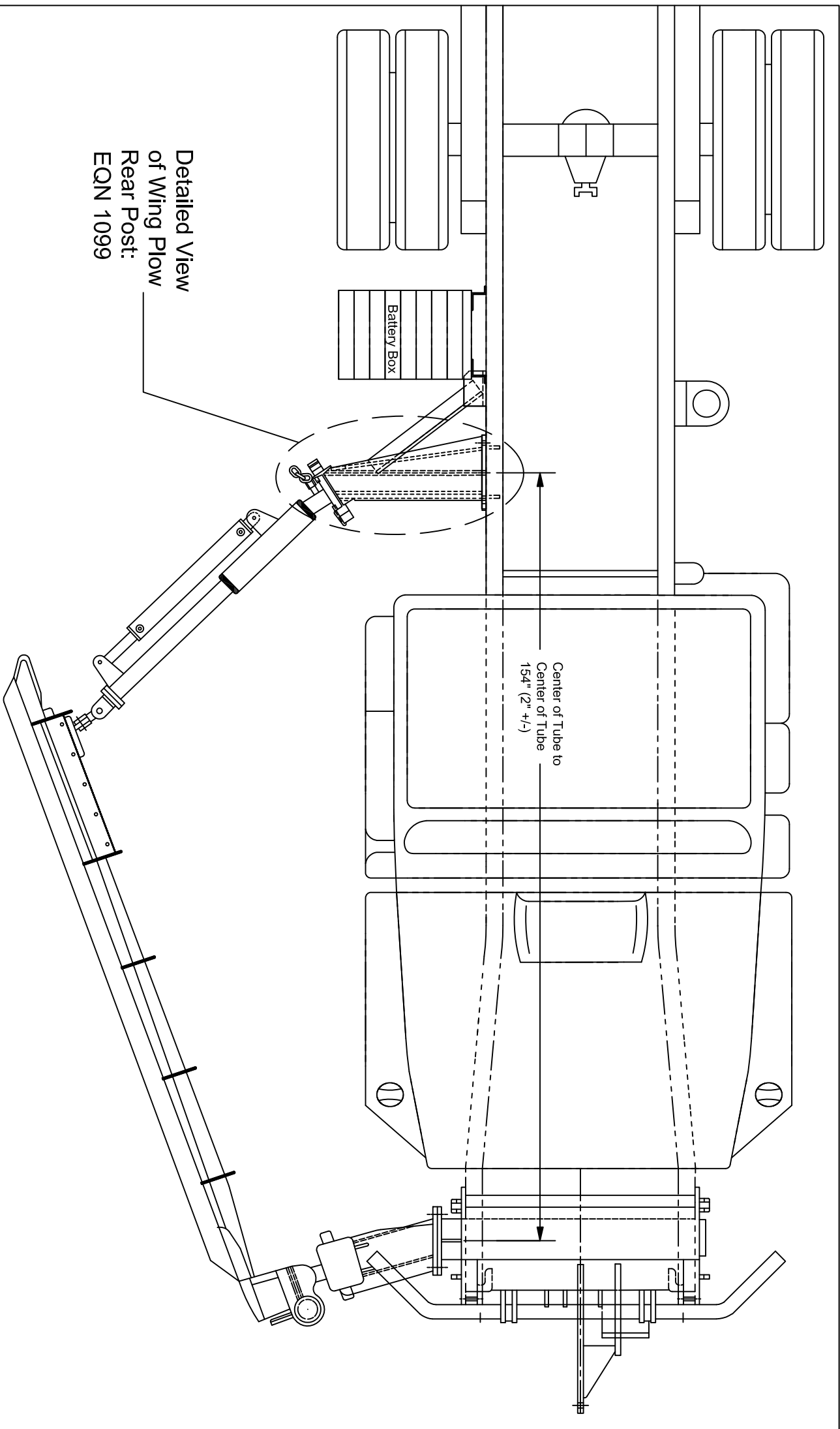

PA DEPARTMENT OF TRANSPORTATION

REVISIONS

NO.	DATE	BY	DESCRIPTION
1			
2			
3			

Wing Plow Tolerance

DRAWN BY: KBD
DATE: 07-12-19
CHECKED BY: []
SCALE: []
EQN-1097

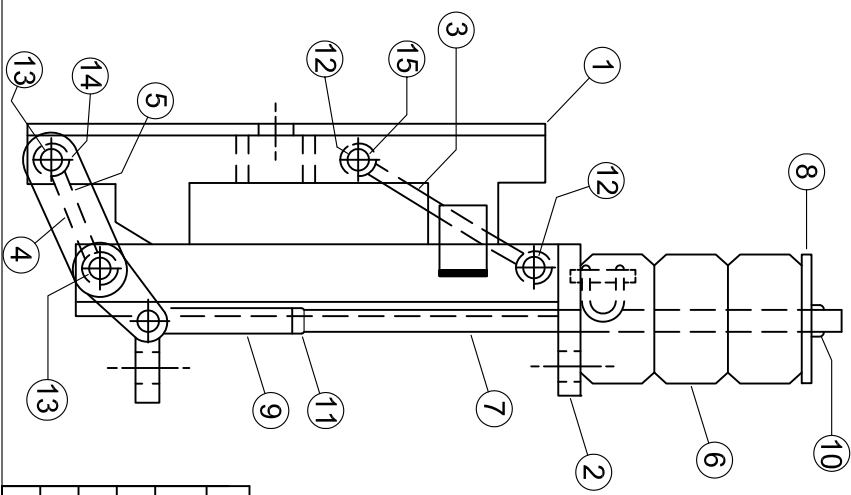
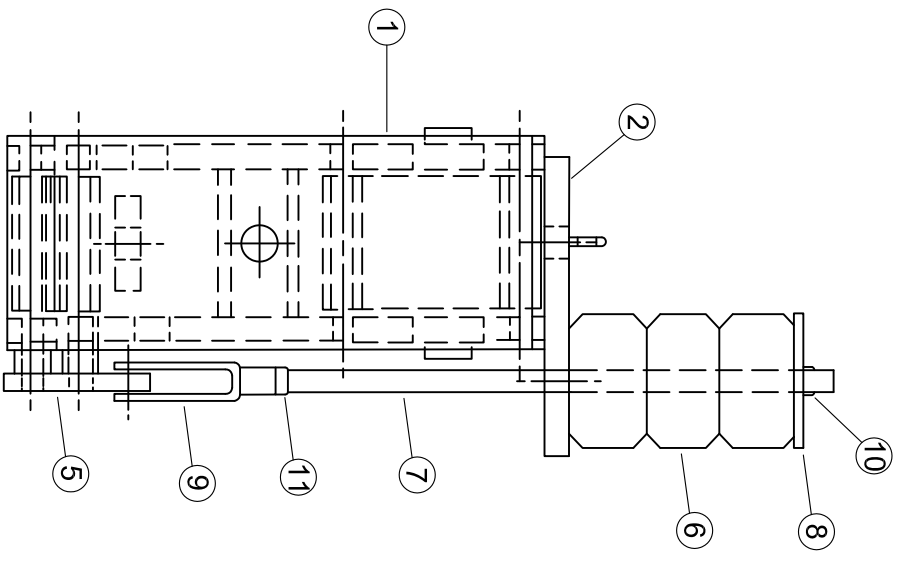
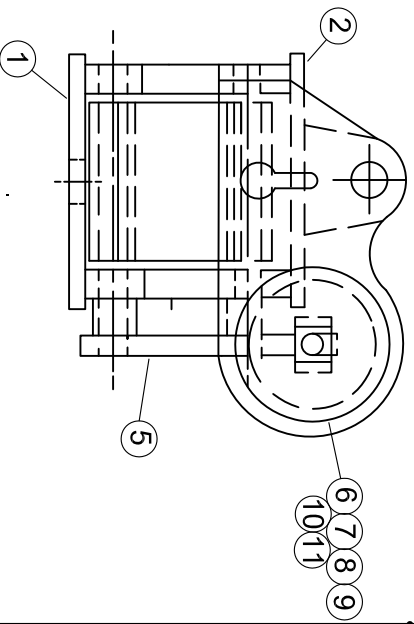

ITEM	PART NO.	DESCRIPTION	REQ'D	NAME
1	17477-B	SEE DRWG.	1	FRONT MTG. PLATE WLDMT
2	17481-B	SEE DRWG.	1	REAR MTG PLATE WLDMT.
3	17485-A	SEE DRWG.	1	TOP LINKAGE
4	17486-A	SEE DRWG.	1	BOTTOM LINKAGE
5	17488-A	SEE DRWG.	1	SIDE LINKAGE
6	P-116-838	AEON A760-75	1	TIMBREN SPRING
7	17489-A	3/4" DIA. ROD x 25 LG. C.F.	1	ADJUSTING ROD
8	17490-A	----	1	SPACER
9	P-116-839	----	1	YOKE
10	P-130-68	3/4" LOCK NUT	1	LOCK NUT
11	P-130-23	3/4" NUT	2	NUT
12	5308-A477	7/8 - 9 UNC x 9 - 1/2 LG. w/LOCK NUT	2	CAPSCREW GR. 8
13	5308-A478	7/8 - 9 UNC x 12 LG. w/LOCK NUT	3	CAPSCREW GR. 8
14	P-129-2	1/8" NPT (SCREW IN STRAIGHT)	1	ZERK
15	P-129-178	1/8" NPT (SCREW IN 45 DEG)	1	ZERK
16	17565-A	SEE DRWG.	1	HINGE PIN

R.H. SHOWN
L.H. OPPOSITE

1 REQ'D PER UNIT

PA DEPARTMENT OF TRANSPORTATION

REVISIONS

TRIP LINKAGE FOR WING

PLOW

NO.	DATE	BY	DRAWN BY	Checked With	DATE
1			KBD		07-18-19
2					
3					

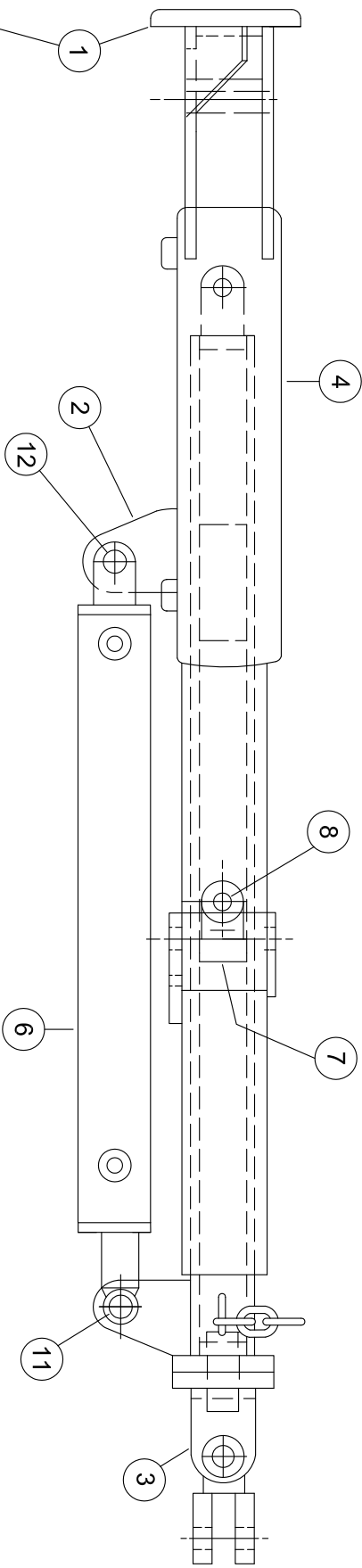

NOTE: GREASE INSIDE
TUBE AT ASS'Y

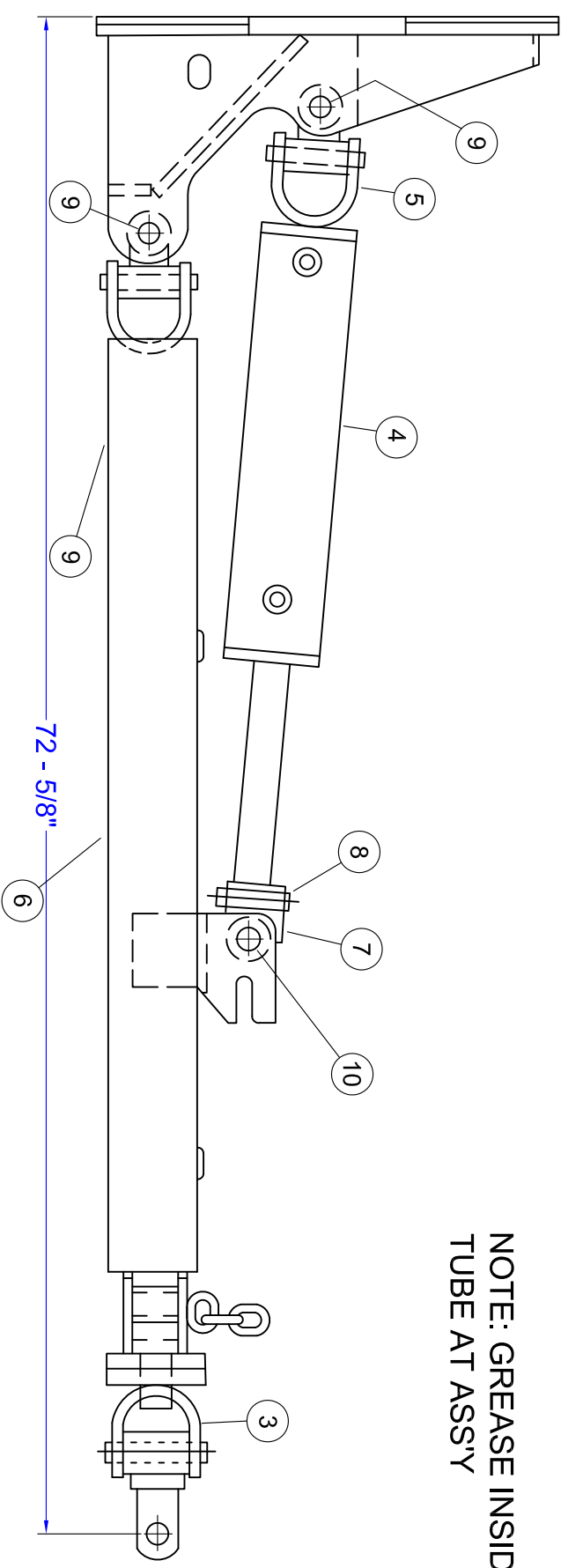

ITEM	PART NO.	REQ'D	NAME	DESCRIPTION
1	17543-B	1	REAR POST SLIDE	SEE DRWG.
2	17550-B	1	OUTER PUSH BRACE	SEE DRWG.
3	17557-B	1	INNER PUSH BRACE	SEE DRWG.
4	P-114-110	1	TOP HYD. CYLINDER	4 X 13-1/4 S.A
5	17551-A	1	SWIVEL FLANGE	SEE DRWG. (USED CYL. ITEM #4)
6	P-114-109	1	SIDE HYD. CYLINDER	3 X 24 D.A.
7	17551-A	1	CYL. ROD END SWIVEL TUBE	SEE DRWG.
8	F-159-4	1	PIN	1" DIA. x 3-1/2" LG. CRR
9	11685-A10	2	PIN	1" DIA. x 5" LG. w/HAIR PIN
10	5308-A377	1	CAPSCREW GR. 8	1" -8 UNC x 6 LG. w/JAM NUT
11	5308-A479	1	CAPSCREW GR. 8	1" -8 UNC x 4 LG. w/JAM NUT
12	5308-A480	1	CAPSCREW GR. 8	1" -8 UNC x 3-1/2 LG. w/JAM NUT

PA DEPARTMENT OF TRANSPORTATION

REAR WING PUSH BRACE
FOR WING PLOW

REVISIONS			DRAWN BY		CHECKED BY		DATE	
NO.	DATE	BY	KBD	Scale	Scale	Scale	Scale	Scale
1								
2								
3								

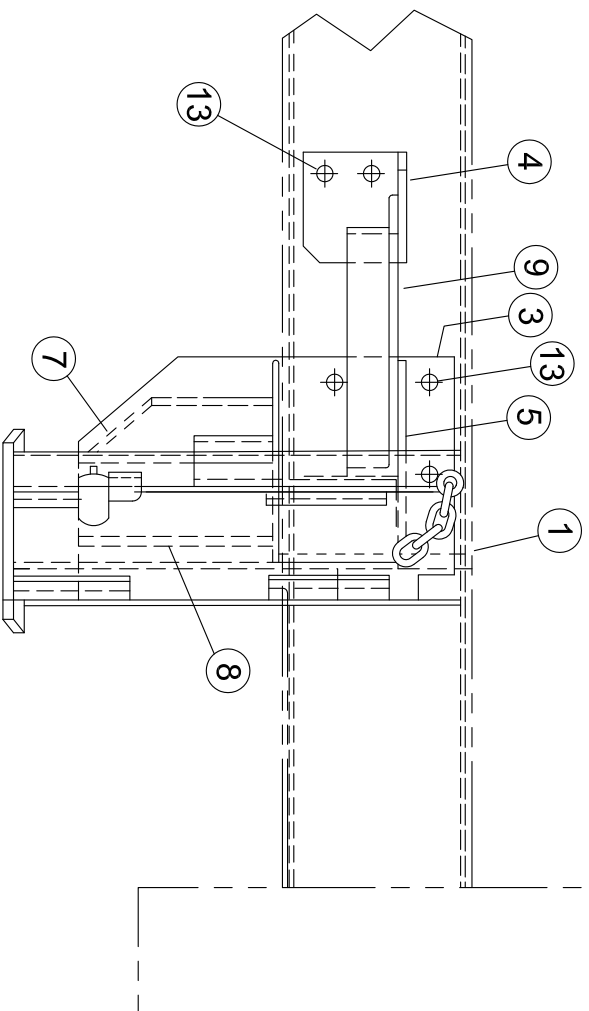
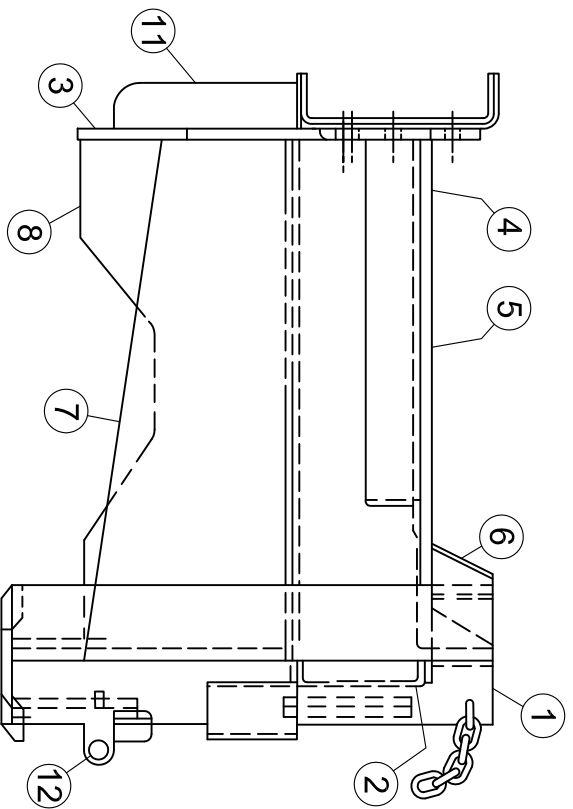
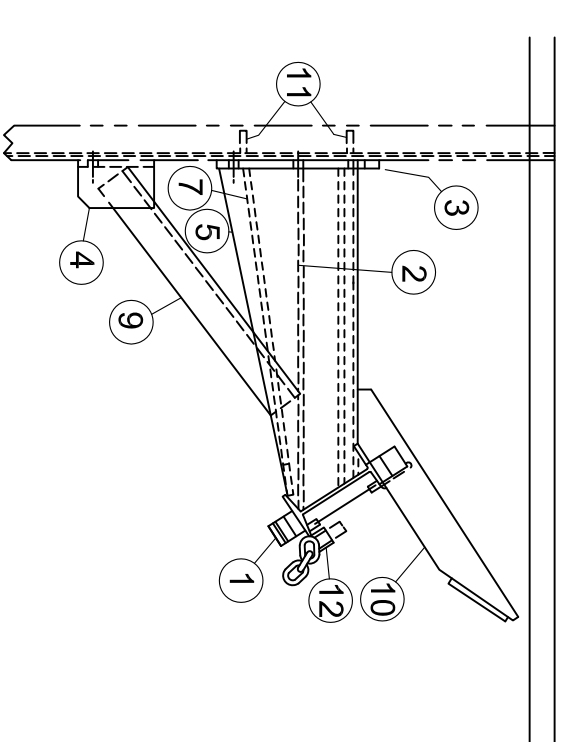

ITEM	PART NO.	REQ.	NAME	DESCRIPTION
1	17569-B	1	I-BEAM W/LD.MT.	SEE DRWG.
2	17570-A	1	RECT. TUBE	SEE DRWG.
3	17571-A	1	SIDE PLATE	
4	17572-A	1	MTG. ANGLE	
5	17573-A	2	REINF. PLATE	
6	5855-A-141	2	GUSSET	
7	17574-A	1	GUSSET	
8	17575-A	1	REINF. BAR	
9	F-118-46	1	REINF. ANGLE	
10	17626-A	1	WING UP STOP	SEE DRWG.
11	14658-A20	2	REINF. BAR	
12	17134-A3	1	PIN	1" DIA. x 5-1/2 LG. w/HAIR PIN
13	5308-A261	7	CAPSCREW GR. 8	3/4-10 UNC x 2-1/2 LG. w/LOCK NUT

PA DEPARTMENT OF TRANSPORTATION

REVISIONS

NO.	DATE	BY
1		
2		
3		

PASS. SIDE REAR POST FOR WING FLOW

DRAWN BY **KBD** Checked With **EQN-1099**
 DATE **07-18-19** CH'D BY **Scale** Sheet 5 of 14

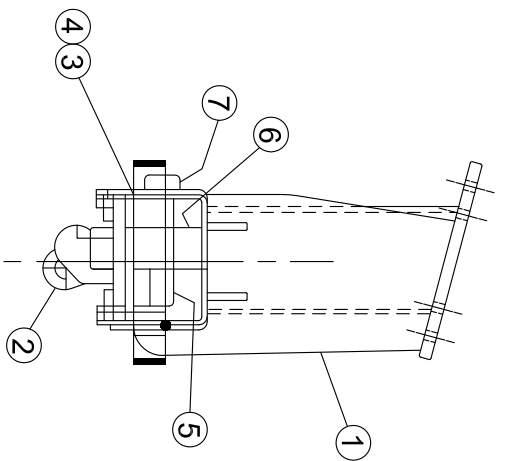

NOTE: GREASE SLIDE
PLATE AT ASSY

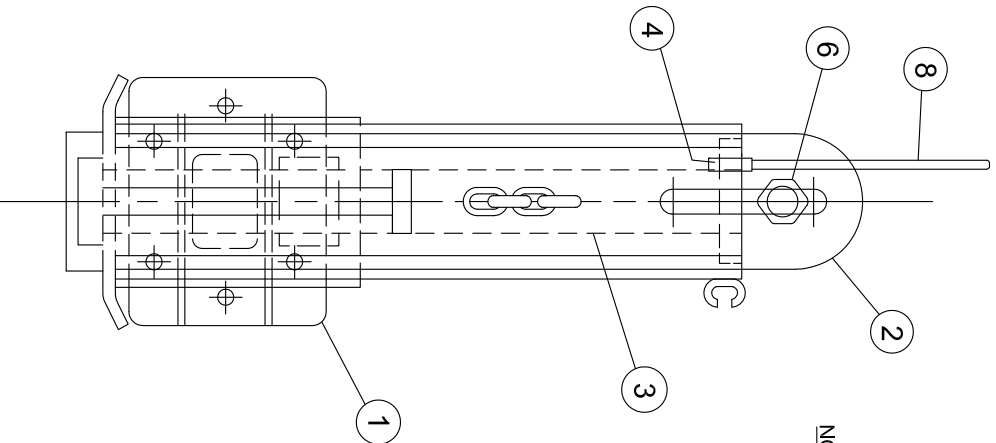

ITEMS	PART NO.	REQ.	NAME	DESCRIPTION
1	17492-D	1	FRONT POST W/LDMT.	SEE DRWG.
2	17502-C	1	SLIDE W/LDMT.	SEE DRWG.
3	P-114-108	1	HYD. CYLINDER	2-1/2 x 15 D.A.
4	17504-A	1	CYL. HOLD DOWN	
5	F-176-3	1	PIN (BOTTOM CYL.)	1-1/2 DIA. x 7-1/2 LG. HRR
6	5308-A475	1	CAPSCREW GR. 8	1-1/4-7 UNC x 6 LG. w/LOCK NUT
7	5308-A476	1	CAPSCREW GR. 8	1/4-20 UNC x 3 LG. w/LOCK NUT
8	P-116-637	1	MARKER POLE	BUYERS

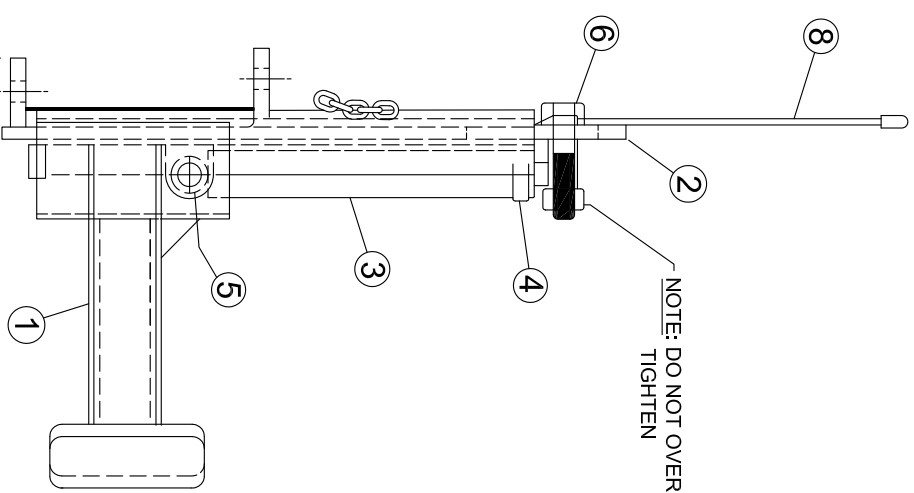

PA DEPARTMENT OF TRANSPORTATION

REVISIONS

NO.	DATE	BY	DESCRIPTION
1			
2			
3			

FRONT POST ASS'Y

DRAWN BY	KBD	Checked With	EQN-1099
DATE	07-18-19	CHK'D BY	Scale
			Sheet 7 of 14

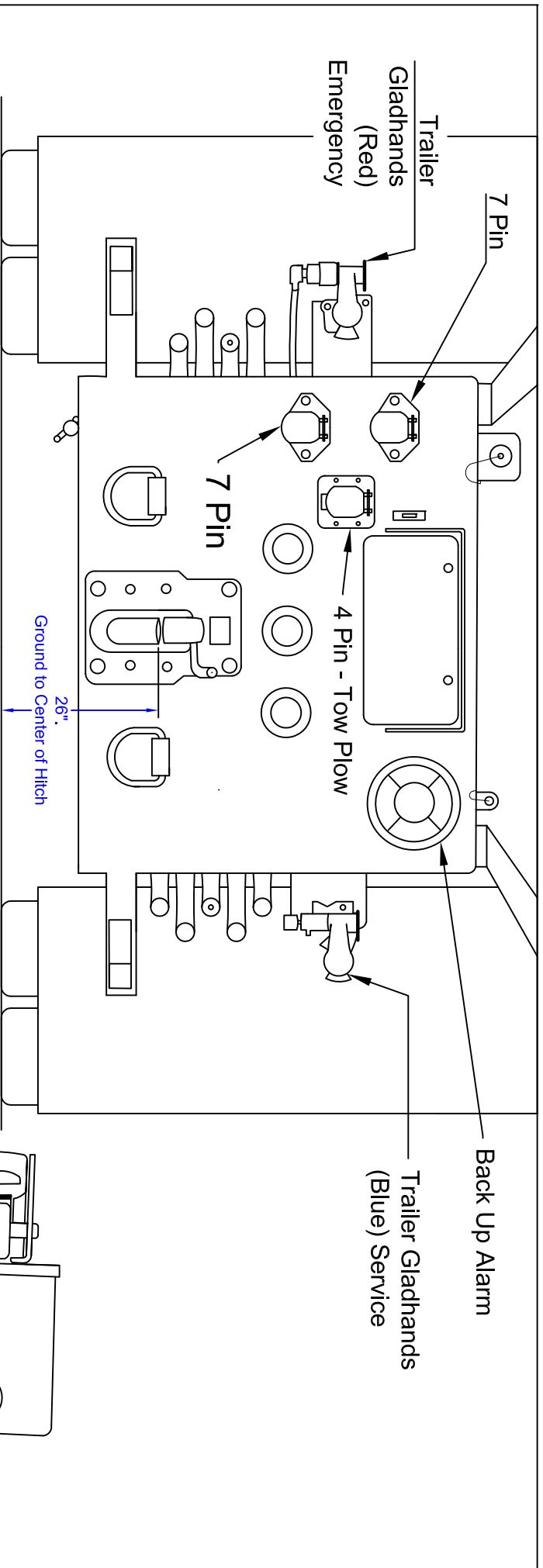

Back View

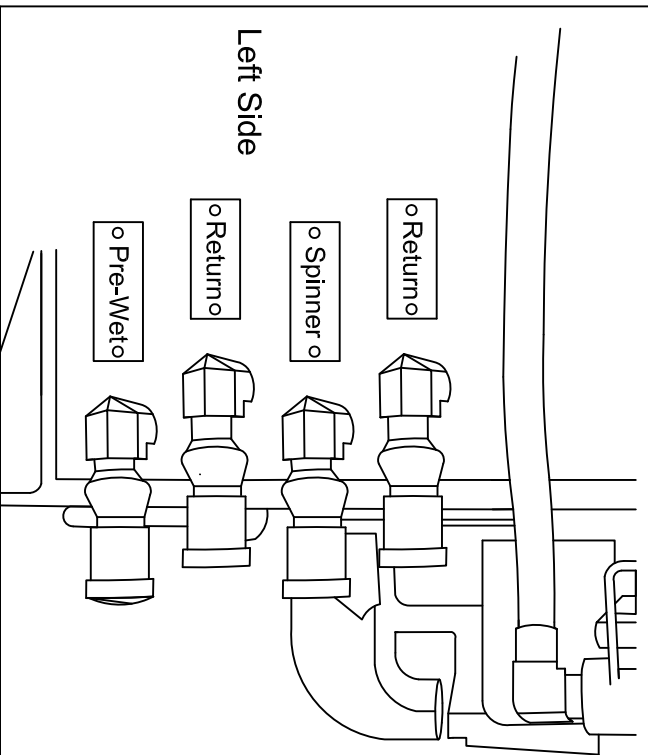

Left Side

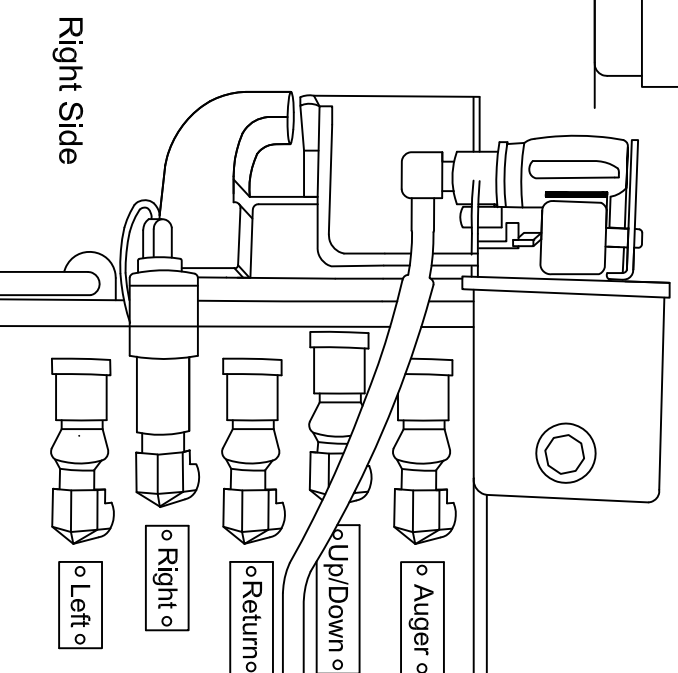

Right Side

PA DEPARTMENT OF TRANSPORTATION

REVISIONS

NO.	DATE	BY	DESCRIPTION
1	05-23-19	KBD	
2	07-15-19	KBD	
3			

Granular Tow Plow Truck

DRAWN BY	KBD	Checked With	EQN-1102
DATE	07-26-18	CHK'D BY	Scale
			Sheet 1 OF 2

NOTES:

- VIEW OF FEMALE CONNECTOR, STANDING AT REAR OF TRUCK, LOOKING AT THE CONNECTOR.
- BRAKE LIGHTS SHALL FUNCTION WITH TURN SIGNALS.
- WIRE SHALL BE 6 WAY (1-10 GAUGE; 6-12 GAUGE) PER ATA COLOR CODE, CLAMPED EVERY 18" MINIMUM.
- CONNECTION SHALL BE MADE USING FACTORY OEM TRAILER WIRING HARNESS.
- ALL CONNECTIONS SHALL BE WATER TIGHT.
- ALL PINS SHALL BE ROUND STYLE.

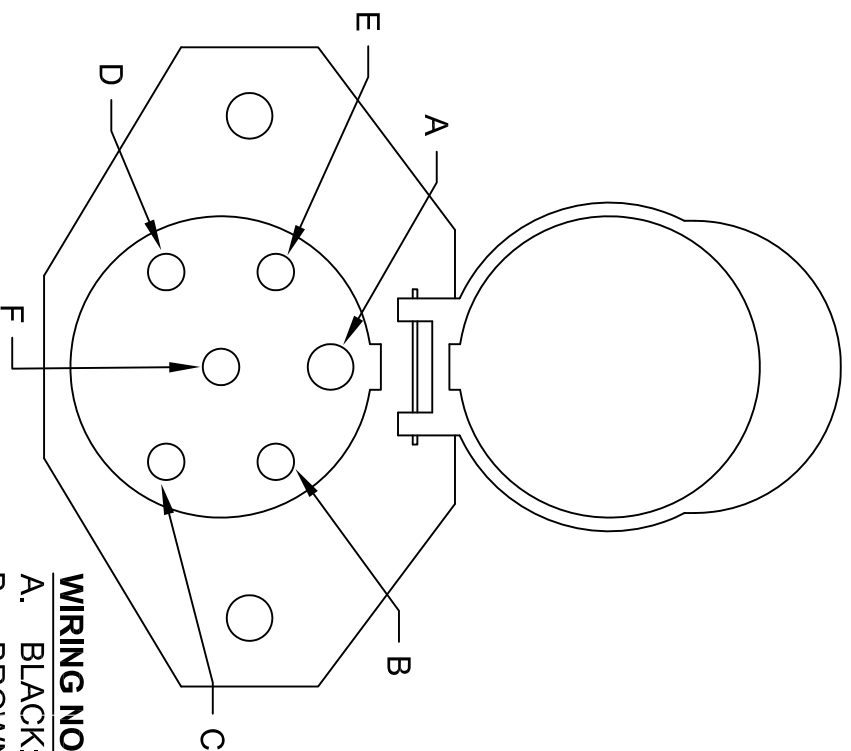

WIRING NOTES:

- A. BLACK: BEACON - 12
- B. BROWN: WING LIGHT -12
- C. GREEN: ---
- D. YELLOW: SIDE STROBE -12
- E. WHITE: GROUND - 10
- F. RED: UPPER REDS - 12

WIRES NEED TO EXTEND 8ft. BEYOND PINTLE.

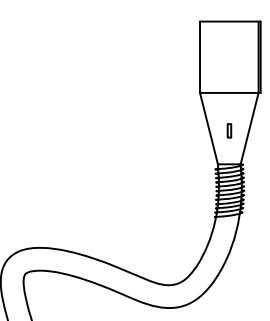

WIRING NOTES:

- A. BLACK: BEACON - 10
- B. BROWN: WING LIGHT - 12
- C. GREEN: ---
- D. YELLOW: SIDE STROBE - 12
- E. WHITE: GROUND - 12
- F. RED: UPPER REDS - 12

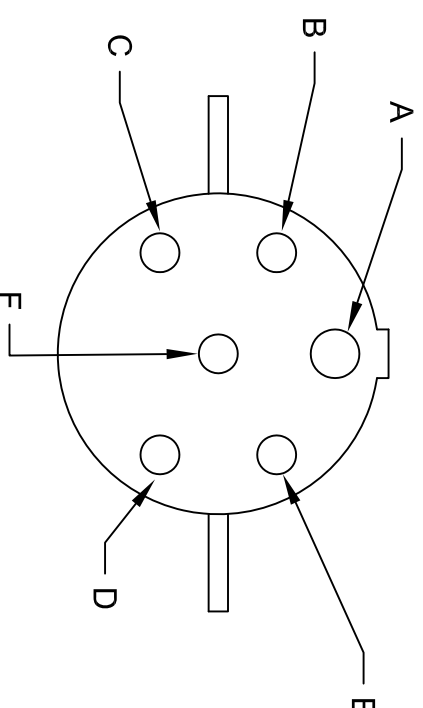

PA DEPARTMENT OF TRANSPORTATION

REVISIONS

NO.	DATE	BY	DESCRIPTION
1	08-02-18	KBD	
2	07-15-19	KBD	
3			

Tow Plow Truck Wiring

DRAWN BY	JJB	Checked With	
DATE	08-02-16	CHKD BY	Scale
			EQN-1102
			SHEET 2 OF 2

- NOTES:
- A) Latch MUST FULLY CLOSE ON TAILGATE ROD AND ENGAGE TAILGATE ROD GUIDE FINGERS.
 - B) LATCH SHALL BE ADJUSTED TO BREAK OVER CENTER WHEN CLOSED.
 - C) LATCH SHALL NOT INTERFERE WITH TAILGATE SWING WHEN LATCH IS IN THE OPEN POSITION.

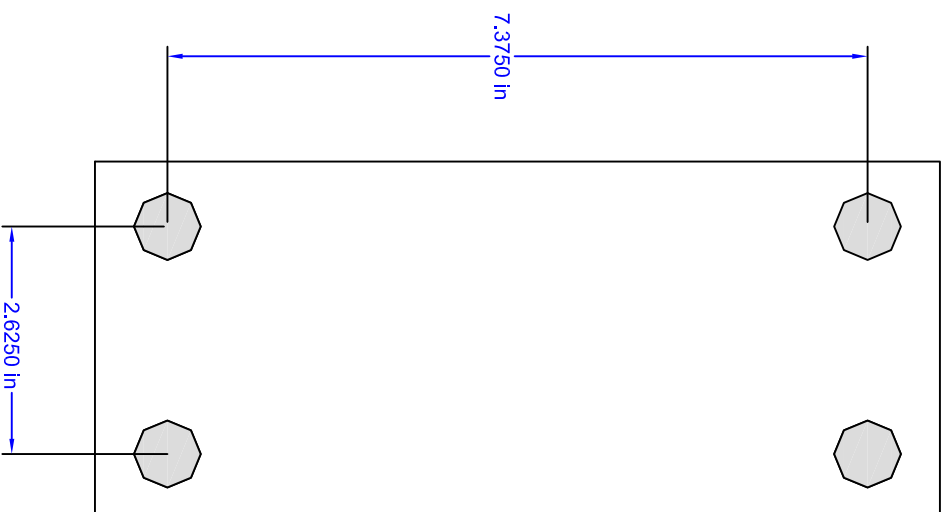
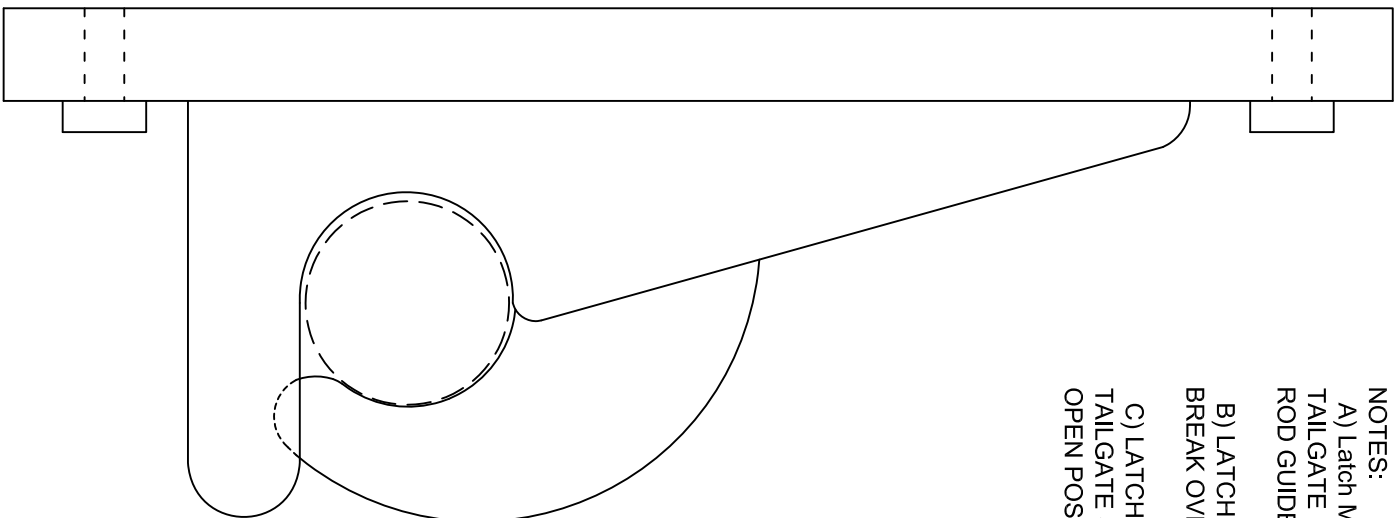

PA DEPARTMENT OF TRANSPORTATION

REVISIONS

NO.	DATE	BY
1		
2		
3		

Dump Truck Latch

DRAWN BY	KBD	Checked With	EQN-1105
DATE	07-29-19	CHK'D BY	Scale
			SHEET 1 OF 1

SPECIFICATIONS

AA1

**TRUCK – DUMP – CONVENTIONAL - 66,000 LB GVWR
HEAVY DUTY TANDEM AXLE DUMP TRUCK WITH INTERNAL FLOOR DUAL AUGERS,
DIRECTIONAL SPINNER (TYPE IV)**

053000 TO 053023

TRUCK, DUMP, TYPE IV, STAINLESS STEEL BED, AUGER FLOOR, FRONT CENTER DISCHARGE
(053000)

TRUCK, DUMP, TYPE IV, STAINLESS STEEL BED, AUGER FLOOR, FRONT CENTER
DISCHARGE, RIGHT WING PLOW **(053001)**

TRUCK, DUMP, TYPE IV, STAINLESS STEEL BED, AUGER FLOOR, FRONT CENTER
DISCHARGE, LEFT WING PLOW **(053002)**

TRUCK, DUMP, TYPE IV, STAINLESS STEEL BED, AUGER FLOOR, FRONT CENTER
DISCHARGE, DUAL WING PLOW **(053003)**

TRUCK, DUMP, TYPE IV, STAINLESS STEEL BED, AUGER FLOOR, FRONT CENTER
DISCHARGE, TOW PLOW ANTI-ICE **(053004)**

TRUCK, DUMP, TYPE IV, STAINLESS STEEL BED, AUGER FLOOR, FRONT CENTER
DISCHARGE, RIGHT WING PLOW, TOW PLOW ANTI-ICE **(053005)**

TRUCK, DUMP, TYPE IV, STAINLESS STEEL BED, AUGER FLOOR, FRONT CENTER
DISCHARGE, LEFT WING PLOW, TOW PLOW ANTI-ICE **(053006)**

TRUCK, DUMP, TYPE IV, STAINLESS STEEL BED, AUGER FLOOR, FRONT CENTER
DISCHARGE, DUAL WING PLOW, TOW PLOW ANTI-ICE **(053007)**

TRUCK, DUMP, TYPE IV, STAINLESS STEEL BED, AUGER FLOOR, FRONT CENTER
DISCHARGE, TOW PLOW GRANULAR **(053008)**

TRUCK, DUMP, TYPE IV, STAINLESS STEEL BED, AUGER FLOOR, FRONT CENTER
DISCHARGE, RIGHT WING PLOW, TOW PLOW GRANULAR **(053009)**

TRUCK, DUMP, TYPE IV, STAINLESS STEEL BED, AUGER FLOOR, FRONT CENTER
DISCHARGE, LEFT WING PLOW, TOW PLOW GRANULAR **(053010)**

TRUCK, DUMP, TYPE IV, STAINLESS STEEL BED, AUGER FLOOR, FRONT CENTER
DISCHARGE, DUAL WING PLOW, TOW PLOW GRANULAR **(053011)**

TRUCK, DUMP, TYPE IV, STAINLESS STEEL BED, AUGER FLOOR, REAR CENTER DISCHARGE
(053020)

TRUCK, DUMP, TYPE IV, STAINLESS STEEL BED, AUGER FLOOR, REAR CENTER DISCHARGE,
RIGHT WING PLOW **(053021)**

TRUCK, DUMP, TYPE IV, STAINLESS STEEL BED, AUGER FLOOR, REAR CENTER DISCHARGE,
LEFT WING PLOW **(053022)**

TRUCK, DUMP, TYPE IV, STAINLESS STEEL BED, AUGER FLOOR, REAR CENTER DISCHARGE,
DUAL WING PLOW **(053023)**

-2-
SPECIFICATIONS
AA1

I. GENERAL TRUCK SPECIFICATIONS:

- A. Intent Statement
- B. Weight Distribution
- C. Power train Overview
- D. Vehicle Components
 - 1. Axle Front
 - 2. Axle Rear
 - 3. Brakes
 - 4. Cab
 - 5. Chassis
 - 6. Drive Line
 - 7. Electrical
 - 8. Engine
 - 9. Exhaust
 - 10. Fast Lube Oil Change System (FLOCS)
 - 11. Frame and Frame Extension
 - 12. Instrumentation
 - 13. Paint
 - 14. Steering
 - 15. Suspension: Front
 - 16. Suspension: Rear
 - 17. Tank- Fuel
 - 18. Wheels/Tires
 - 19. Transmission

JAH/JKF/GAW August 27, 2020

-3-
SPECIFICATIONS

AA1

I. GENERAL TRUCK SPECIFICATIONS: (Continued)

- E. Dump Body and Equipment Mandatory Minimum Specifications
 - 1. Stainless Steel Dump Body Structure
 - 2. Central Hydraulic System/Hydraulics
 - 3. Tarping System
- F. General Plow Mounting/Accessories
- G. Optional Temperature Sensor
- H. Optional AVL Hardware
- I. Optional Wing Plow Specifications
 - 1. Intent Statement
 - 2. Specifications
 - 3. Minimum Alterations
 - 4. Plow Identification
 - 5. Paint
 - 6. Conspicuity Tape
 - 7. Wing Plow Light
- J. Optional Tow Plow
 - 1. Tow Plow Anti Ice Hitch Upgrade Option
 - 2. Tow Plow Granular Hitch Upgrade Option
- K. Installation Practices
- L. Safety

II. DRAWINGS:

III. MANUALS:

IV. TRAINING:

V. WARRANTY:

-4-
SPECIFICATIONS

AA1

I. GENERAL TRUCK SPECIFICATIONS: (Continued)

A. INTENT STATEMENT:

Intent: The purpose of these specifications is to describe a conventional cab, tandem axle dump truck, equipped with dual rear wheels, 13.5 foot dump body, and 12 cubic yard approximate load capacity with either a **Front Center Discharge** or a **Rear Center Discharge**. 201 stainless steel body of a radius design, dual auger, underbody center mounted hydraulically adjustable directional spinner, hoist, hydraulic power system and snow plow hitch. The radius design shall provide consistent flow of materials to the dual auger without the need to raise the bed. It shall be capable of one-man operation while plowing snow and simultaneously spreading granular and liquid materials during winter operations (without the need to raise the bed), and of hauling, stockpiling and unloading maintenance materials into a chip spreader or paver during summer operations. The body shall be capable of having the following components connected and or mounted to it: wing plow, and tarp. Further, it shall be capable of being loaded with a front-end loader or self-propelled belt loader.

Pennsylvania Department of General Services, PCID No. 1075, "*General Requirements for Bidding PennDOT Vehicles/Equipment*", most current version effective at the time and date of bid opening is included as a part of this specification. PCID No. 1075 may be reviewed and downloaded from the Department of General Services website, <http://www.dgs.state.pa.us>. Delivery as required per Department of General Service PCID NO. 1075 Section "G". All units must be delivered within **300** days after receipt of the purchase order by the successful bidder.

Awarded OEM vendor shall be responsible for contacting the Specification Section of the Fleet Management Division at (717) 787-1567 to set up a pre-build meeting for all chassis and body mounting component locations prior to chassis build. Any deviations to the specification must be granted in writing by the Chief of the Specification Section, previous acceptance will not be considered pre-approved. It shall be understood that any discrepancies/deviations between the specification and the completed unit(s), chassis or body up-fitter related, must be addressed and corrected prior to the delivery deadline and the Departments acceptances.

Unit shall be delivered clean, with current PA state Inspection and a full tank of fuel.

All component manuals and weight distribution sheets shall be completed and supplied with the Pilot unit and the subsequent delivery of each unit.

-5-
SPECIFICATIONS

AA1

I. GENERAL TRUCK SPECIFICATIONS: (Continued)

B. WEIGHT DISTRIBUTION:

Weight distribution charts must be submitted with the pilot model for all models being delivered. Weight distribution charts shall be submitted for two modes listed below.

1. Summer mode including the portion of the wing plow post and plow frame assembly that remains on the vehicle all year.
2. Winter mode with front plow, loaded pre-wet tank, spreader and complete wing plow.

Each item listed on Drawing EQN-507B shall be noted and individually calculated in the vendor's submission. Engineering certified weigh slips shall be provided with the pilot model and signed by the Manufacturer's Engineering Department. It is understood that the components specified are minimum and if the manufacturer's Engineering Department recommends or deems necessary, particular weight distribution, a larger component or a larger GAWR totally, the burden of responsibility is hereby placed upon the Manufacturer's Engineering Department to supply a unit that is totally engineered.

1. Frame
2. Axle
3. Tires
4. Steering unit and components
5. Rims
6. Suspension
7. Brakes
8. Any other items as required

-6-
SPECIFICATIONS

AA1

I. GENERAL TRUCK SPECIFICATIONS: (Continued)

B. WEIGHT DISTRIBUTION: (Continued)

1. The dynamic and static loads created by the unit, plus operational stresses, must be reviewed to ensure the Commonwealth of a properly designed/engineered unit.

2. Front and rear axle legal weight distribution apply to non-emergency applications only! Winter weight distributions are required for payload information purposes only since winter plowing and spreading operations are exempt from legal weight restrictions. However, the total weight rating shall not exceed the manufacturer's GVWR for the vehicle that is offered. The weight imposed on the front and rear axles using the total GVWR shall be shown. (Overweight shown on the axles in these winter modes is for information only).

In addition to the Engineering Certified weight distribution provided at the pilot model inspection, the following information is required with the pilot model.

The vehicle shall be certified for 66,000 LB Gross Vehicle Weight Rating (GVWR). The GVWR shall be identified in the cab or on the door as the final complete certification label (minimum rating).

ACTUAL TRUCK WEIGHT: (LB)

"Chassis only" (shall be signed by a certified weigh master.)

_____ Front Axle

_____ Rear Axle

_____ Total

"Chassis with body" (shall be signed by a certified weigh master).

_____ Front Axle

_____ Rear Axle

_____ Total

THE ABOVE MAY BE PERFORMED BY THE BODY COMPANY.

-7-
SPECIFICATIONS

AA1

I. GENERAL TRUCK SPECIFICATIONS: (Continued)

B. WEIGHT DISTRIBUTION: (Continued)

Truck GAWR's as Built (LB)

	<u>Front GAWR</u>	<u>Rear GAWR</u>
Axle	_____	_____
Tires	_____	_____
Springs	_____	_____
Rims	_____	_____

C. POWER TRAIN OVERVIEW:

ENGINE

DIESEL, MIN. 425 HP AT GOVERNED RPM, MIN. PEAK TORQUE OF 1540 LB/FT TORQUE, MIN. 12.4 LITER (actual engine liters).

***OPTION Tow plow upgrade equipped chassis shall be increased to a MIN. 455 HP at Governed RPM.** If additional HP is available, it may be included in an effort to give the Department the maximum HP and or Torque available.

TRANSMISSION

AUTOMATIC- ALLISION 4500 RDS 6 SPEED

REAR AXLE

DANA DT463P
MERITOR RT46 -164 -P
MACK S462

Lubricants for front axle hubs, automatic transmission and all rear axle differentials shall meet or exceed all appropriate MIL and SAE specifications for synthetic lubricants and shall have all plugs identified as synthetic oil, or painted red. All axles shall have magnetic drain plugs.

-8-
SPECIFICATIONS
AA1

I. GENERAL TRUCK SPECIFICATIONS: (Continued)

D. VEHICLE COMPONENTS:

1. AXLE FRONT:

20,000 lb. axle manufactures standard wheel seal
MERITOR MFS-2
MACK FXL 20
DANA D-20000F

The front axle shall be rated at 20,000 LB minimum capacity. The front axle drag links and tie rods shall have grease zerks installed. Kingpin or bushings shall be grooved to permit grease flow. Sufficient tire clearance at maximum turning angles. Complete oil seal assembly, including hub, plug type window, and seal. Each unit shall receive a front-end alignment prior to delivery. A setback axle is unacceptable.

2. AXLE REAR:

DANA DT463P
MERITOR RT46 -164 -P
MACK S462

Rear axles shall be rated at 23,000 LB. each.

Aluminum or lightweight housing is unacceptable. Only heaviest duty housing will be accepted.

All rear axles must provide axle shafts with a minimum diameter of 2.19 inch at the spline. All rear axle(s) shall have an extended breather tube to prevent debris buildup from entering axle housing. There shall be a torque-proportioning traction-assist device, which is full locking within the differential housing. The device shall provide maximum traction to the rear wheels when actuated and shall be a self-relieving designed to prevent gear damage and/or axle shaft breakage under extreme service conditions. The traction-assist device shall be driver actuated by a dash mounted traction control switch.

Lubricants for all rear axles shall meet or exceed all appropriate MIL and SAE specifications for synthetic lubricants and shall have all fill plugs identified as synthetic oil, or painted red.

Stemco guardian or SKF Scotseal, Chicago Rawhide rear wheel seals, or approved equal. All axles shall have magnetic drain plugs.

The following information shall be presented at the pre-build meeting.

Rear axle selection shall be made after the award and may be a mix of ratios as required. The successful vendor/manufacturer shall present three (3) computer runs showing the three most likely ratios for consideration for a top speed range of 55 MPH to 65 MPH max. Gear Selections shall provide gear ranges at 25 MPH & 35 MPH with a 1600 RPM to 1900 RPM range for plowing and spreading operations.

The rear axle ratios must be "identical" throughout the entire build.

3. BRAKES:

Full air antilock in compliance with the most current FMVSS requirements.

The ABS shall incorporate a diagnostic display capable of retrieving SAE fault codes. The activation switch shall be easily accessible and can be either dash or steering column mounted. A dash-mounted display that will show all SAE message descriptions for the ABS shall be easily navigated and viewed from the driver's seat.

Rear brakes: 16.5-inch x 7 inch "S" cam with quick-change type double anchor pin. Meritor Q+ (**No substitute, standardization**).

Steer-axle-brake: 16.5-inch x 6 inch "S" cam with quick-change type double anchor pin. Meritor Q+ (**No substitute, standardization**).

-9-
SPECIFICATIONS

AA1

I. GENERAL TRUCK SPECIFICATIONS: (Continued)

D. VEHICLE COMPONENTS: (Continued)

3. BRAKES: (Continued)

Drum brakes shall have automatic slack adjusters and they shall be clearance-sensing type only, with adjustment on application of the brake. **(No substitute, standardization)**. Backing plates shall be installed on all drum brakes.

Air compressor: Per truck manufacturer's recommendation. Compressor shall be fitted with a safety valve to prevent mechanical failure.

Low air pressure indicator: Buzzer-type and dash light. Must meet current Federal DOT guideline requirements. Air gauge shall display in 5lb. increments. Digital numerical readout is acceptable. Air gauge and low air warning buzzer shall operate with key switch **on** and engine **off**. Function shall not have capabilities of being deactivated by the operator.

Parking brake: Rear wheel spring-type, MGM E 30/30 or Haldex 30/30 gold seal chambers. Parking brake shall provide modulated emergency braking via the foot valve in the event of a rear service system failure.

All brake chambers, front and rear, shall be equipped with rubber boots on the brake chamber push rods.

Rear service brake chambers and spring brake chambers shall be mounted to provide adequate clearance for backing into bituminous paving machines.

Air tank: Automatic drain valve, with heater on wet (first) tank. Each of the remaining air tanks shall have a manual drain valve.

Air dryer: With heater, mounted away from road splashing and a minimum of 20 inches above road surface. Dryer shall be compatible with the body company clearance requirements for sub-frame, valve body, etc. Bendix AD-IP **(No substitute, standardization)** installation made in concurrence with the air compressor manufacturer's recommendations.

Air dryer shall be placed outside of frame rail to accommodate the changing of filter cartridges without disconnecting any hoses or removing dryer base from its mounting location. **Final mounting location shall be determined at Pre-Build meeting.**

System shall be equipped with anti-compounding valve to prevent mechanical failure of the foundation brakes, slack adjusters, etc.

Trailer air brake: Unit shall be equipped with factory installed trailer air brake control package. To include dash mounted, graduated, hand operated, trailer service brake trolley control valve. Body builder to mount and install Phillips STA-LOCK glad hands (1 each part numbers 12-4906 and 12-4908), location to be determined at pre-build meeting Ref: EQN-79AF.

4. CAB:

Aluminum or galvanized steel cab.

Grab handles shall be supplied on all cab entry locations. Three points of contact shall be achievable at all cab entry locations. Handrails shall be coated with non-skid paint (non-skid tape is unacceptable) or have OEM anti-slip rubber inserts, both non-skid paint or rubber inserts must extend the full length of the grab handle.

Exterior grab handles shall be supplied if available from OEM.

Hood: Fiberglass, tilting. Fenders shall be part of tilting hood. Grille shall be fixed and constructed of a non-rusting material. Hood shall be one-piece design, high visibility, and without any access panels.

Air suspension system for the cab shall be factory installed.

Air deflector: Clear or smoke, hood mounted. Manufacturer's standard full width for the truck model. Access to front-end hood tilt handle shall not be blocked.

Fenders: Front fenders shall have a formed extension. Not to exceed 102-inch truck width

Deluxe fresh air hot water heater and defroster, manufacturer's highest output.

Air Conditioning: Highest output available as OEM option.

AM/FM radio with weather band and wireless hands-free cell phone connection

Air horn(s): Minimum 1 horn with snow-shield (not required if under hood mount).

-10-
SPECIFICATIONS

AA1

I. GENERAL TUCK SPECIFICATION: (Continued)

D. VEHICLE COMPONENTS: (Continued)

4. CAB: (Continued)

All controls and knobs shall be properly identified.

Brake pedal and throttle shall be suspended if available from the factory.

CB Power connections One (1) pair, on the dash, Ref: EQN-78.

Cab floor covering shall be heavy-duty rubber with closed cell rubber or heavy felt backing.

Covering shall seal against all mating and adjoining surfaces sealing dirt and liquid on the surface keeping it from penetrating or accessing the metal cab flooring causing corrosion from inside the cab.

Cruise control

Cup holder in the cab within easy reach of the operator.

Dome light shall be provided

Dual sun visors.

Drivers and passenger's side windows shall be power.

Driver's and passenger's doors shall be equipped with power door locks.

Windshield: Manufacturer's standard heated windshield. One (1) or two (2) piece construction is acceptable, must be tinted. Safety glass throughout.

Dual windshield wipers, arctic type with the heaviest arms, linkages and motor available. Wipers shall be minimum 2-speed electric with intermittent feature

Washer system shall be electric. Minimum capacity of two (2) quarts of washer fluid and shall be filled with an anti-freeze type solvent. Washer fill point shall be located to be accessed from ground level, without overhead reaching. With unobstructed and unrestricted flow from a one-gallon jug.

Mirrors: Driver and passenger side west coast style powered mirrors with manufactures standard heavy-duty breakaway arms. Mirrors shall have a minimum 105 square inch reflective surface. Mirrors shall be heated with a lighted toggle switch mounted within accessible reach of the operator, automatic on/off is acceptable. There shall be a heated convex mirror, minimum 50 square inch reflective surface. A heated blind-spot elimination mirror shall be mounted on the right front fender and it shall be minimum 50 square inch reflective area, stainless steel or aluminum head. Mirror shall be a conventional convex mirror and shall not be of the half-round cross view type. All mirror wires shall be fitted in such a way that the mirror glass/element can be changed by unplugging the two-wire lead. All arm/s and hardware shall also be stainless steel. Fender type washers, stainless or aluminum, with rubber pads shall be placed on both sides of the fender. Pedestal system shall be single, double or triple mounting assemblies (stainless steel or aluminum). Mirror shall be mounted in rubber or vinyl.

Seats: Driver's seat shall be high back adjustable Bostrom air 915 Series with lumbar support or National 195 Series with lumbar or DuraForm Air Command Series (fabri form cushions with lumbar support), with body cloth insert and three-point retractable seat belt (Seatbelt shall be High Visibility Orange). Seat belts shall be equipped with a comfort lock. A bellow-type or protective skirt shall cover the seat suspension mechanism.: If due to cab configuration a Bostrom 915 or National 195 seat cannot be used, a Bostrom 910 may be substituted. All other requirements must be met. There shall be an inside armrest on the driver's seat plus an outside armrest installed on the seat or the driver's door. **(No substitute, standardization)**. Color coordinated to cab interior. Passenger seat shall be the manufacturer's standard non-suspension (static) high back type and shall have a three-point retractable seat belt (Seatbelt shall be High Visibility Orange). Color coordinated.

Seat Safety Switch: Drivers seat shall be equipped with a factory safety switch to work in conjunction with the central hydraulic system. Switch shall be rated at 7 lbs. and shall allow operation of the hydraulic auger spreader and spinner system when occupied and shut down the hydraulic auger spreader and spinner system ONLY when unoccupied.

Seat switch shall have all necessary components and connections to delay seat switch deactivation of auger and spinner circuit ONLY for a minimum of five (5) seconds and maximum ten (10) seconds.

-11-
SPECIFICATIONS

AA1

I. GENERAL TUCK SPECIFICATION: (Continued)

D. VEHICLE COMPONENTS: (Continued)

4. CAB: (Continued)

Deactivation of the seat switch system shall activate a message on the spreader control screen display "AUGER & SPINNER STOPPED", this feature shall not cause any other interruptions or faults in the hydraulic/spreader system.

Reactivation of the seat switch system shall not require any action or input from the operator for operation of the complete hydraulic/spreader system.

It shall be the sole responsibility of the OEM to ensure seat safety switch compatibility with the selected hydraulic system manufacturer control system. Aftermarket installation of this switch is unacceptable.

Steering wheel diameter shall be 18 inch (approx.), Manufacturers standard.

Steering Column: Steering wheel and column shall be tilt and telescopic, infinitely adjustable to multiple positions.

Road & Air Temp: There shall be a Vaisala Surface Patrol DSP100 road/air temperature system installed with control system integrated temperature display. **(No Substitute, standardization)**

Steps: Drivers and passenger entrance steps: Shall be aluminum, serrated. The outer step edge must be serrated in lieu of plain. (Overlay is not acceptable). Step design material must be the same, both left and right side. Ref: Bustin.

Top of the first step shall be approximately 21 inch above the ground.

Wiring Pass Through: All wiring entering the cab shall be made through a rubber boot assembly and be weather tight. There shall be no connectors in the wiring at the pass-through point. Wiring shall be protected against sharp edges and from rubbing / chaffing. Boot design shall be pre-approved.

5. CHASSIS:

The GVWR rating of the truck shall be 66,000 LB. A label stating this shall be affixed on the door or in the cab as the completion certification label.

CT dimension: 126.9 inch approximate cab to center of trunnion. Wheel base dimension 214 inch approximate. Wheelbase and CT dimension may be adjusted to provide the optimum legal weight distribution and to meet the vehicles intent statement.

The frame AF shall incorporate a cross member at the rear of the frame (Local installation is acceptable) to reinforce the body pivot point. Cross member may be deleted if body up fitter's engineering determines a cross member is not needed due to pintle plate installation. EQN-79AF

Front Bumper: Heavy duty swept back design, mounted to the frame with the inner face of the bumper against the chassis frame.

Frame mounted tow hooks or eyes: Two (2) front. These may be installed by the body company after completion of the plow hitch mounting, using grade 8 bolts (minimum) of sufficient length, and grade 8 elastic type self-locking nuts, or by full welding.

License plate bracket rear securely mounted to prevent damage when backing into material piles. EQN-79AF

There shall be a centralized-on board chassis lubrication system installed, manufactured by SKF Lincoln Industrial Model# 94012 **(No Substitute, standardization)** Ref: EQN-501.

6. DRIVE LINE:

Main driveline: Spicer Life HDXL or Meritor MXL Series. **"Factory balanced"** greasable, (one zerk minimum). Heavy-duty driveline shall be engineered and be compatible to engine, drive train and transmission torque. Heavy-duty center bearing, if required, with due consideration to drive shaft angles, length, location, proper bolting based upon engine and transmission selection. Inter-axle driveline: Spicer Life XL or Meritor MXL Series.

-12-
SPECIFICATIONS

AA1

I. GENERAL TRUCK SPECIFICATIONS: (Continued)

D. VEHICLE COMPONENTS: (Continued)

7. ELECTRICAL:

All copper system, negative ground.

Alternator: Delco 36SI (**No substitute, standardization**) 160-amp minimum, high performance, solid state, brushless, with battery cable from battery negative terminal to starter motor or frame. All alternator and starter bolts shall be grade 8

Batteries: Three (3), heavy-duty, 12-volt, maintenance-free, BCI Group Size 31, with stud-type posts and anti-corrosion treatment on each terminal. 2500 total cold cranking amperes (CCA) at 0 degrees F. 540 minutes of total reserve capacity at 80 degrees F as per SAE.

Battery Mounting: Mounting shall include the following:

- a.) 0.25-inch-thick rubber shock pad under the battery.
- b.) Box with cover. Cover shall be constructed of fiberglass, poly, or aluminum (if aluminum there shall be an insulated liner).
- c.) Mounting bolts shall be grade 8 with self-locking nuts.

All OEM connections within the battery box shall have attached non-metallic embossed labels/tags. Labels/tags applied with self-adhesives or stickers will not be accepted.

Mounting of accessories within the battery box is prohibited. Any connections that are essential in the battery box must be pre-approved by the Chief of the Specification unit at the Fleet Management Division in writing (717) 787-1567. Any circuit deemed necessary for connection in the battery box by the body up-fitter or component manufacturer shall have attached non-metallic embossed labels/tags. Labels/tags applied with self-adhesives or stickers will not be accepted.

All circuits shall be individually permanently labeled.

Cables shall conform to RCC Practice 105 with "sealed" terminal ends for stud-type battery posts.

Starter motor: Delco 39MT (No substitute, standardization) starter with thermal over crank protection and high torque capacity. Suitable for the diesel engines offered as per starter manufacturer's recommendation.

Electrical system: System shall be circuit-breaker-equipped, in an easily accessible location and weatherproof. Fuses acceptable in circuit so identified by manufacturer as safety factor. Any fuse or circuit breaker liable to be damaged during truck operation shall have an easily removable protective cover. All wire splices in the cab shall be insulated with heat shrink materials

Electrical chassis wiring: Factory heavy duty harness to power components in rear light module. Trailer light plug shall have brake lights operate in conjunction with the turn signals. per EQN: 80A

Flasher: (All) heavy-duty electrical, Ref: Tridon Model EL 12 or OEM Heavy Duty Electronic Flasher.

If an audible alarm is supplied for the 4-way and turn signal circuit, it shall have on/off capability.

Lights: All lights shall meet all Federal and State regulations. The head Lights shall be Halogen with (DRL's) daytime running lights. Body lights shall have their own dedicated complete circuit. The chassis manufacturer shall route the dedicated body circuit/harness to the rear center portion of cab, with 4' of extra wire coiled on floor between seats. All pass-through points shall be properly sealed and protected. This shall be the access/connection point for the Whelen Model # 01-1518839-13B, old PN# PADOTS13V. Pass-through point and/or routing location determined at Pre-build Meeting.

Plow Lights: Shall be Trucklite Halogen head lamps Part# 80894 and 80899. (**No substitute, standardization**). Bracket design shall be either aluminum or stainless steel. Brackets shall be designed/constructed to provide sustained support of the light assembly while offering minimum vibration. Brackets shall be designed to place center of plow light lens approximately 80 inches from ground level and be adjustable vertically 3-inch up and 3-inch down. Ref: EQN-180. The height and width of the bracket will be governed by the application and shall meet all Federal and State lighting regulations. Awarded vendor shall supply plow light bracket design drawing(s) to the Fleet Management Division Specifications section for consideration. Final design shall be approved in writing from the specifications section chief at the pre-build meeting. The factory chassis plow light circuit shall be used and all areas where the wires might contact a rub point shall be protected by grommets, loom, etc. All connections shall be made using sealed connections and dielectric grease. Ref: EQN-180.

-13-
SPECIFICATIONS

AA1

I. GENERAL TRUCK SPECIFICATIONS: (Continued)

D. VEHICLE COMPONENTS: (Continued)

7. ELECTRICAL: (Continued)

Radio Antenna: There shall be an antenna base, NMO and a VHF StiCO Roof-FT-NITI-M whip shall be cut to 18.0 inches per manufactures cut sheet. Assembly shall be mounted to the passenger side mirror bracket and routed internally with mirror wiring with the antenna cable routed (within protective conduit) to the floor area between the seats. There shall be a minimum of 4 feet of antenna cable coiled at the base of the floor to allow for connection of radio on spreader control pedestal. Antenna shall be prewired with a UHF MALE connection. **(No substitute, standardization)**. Antenna shall be mounted to not interfere with cab shield.

Power Distribution Center: There shall be a 4-way power/ground distribution center located near the console for connection of 800 MHz state radio. The lugs shall be labeled and configured in the following manner: (1) lug shall be a 30-ampere constant hot circuit, (1) lug shall be a 10-ampere ignition-controlled circuit. (2) lugs shall be chassis ground. All connections shall be enclosed in a weatherproof enclosure: EQN-562

Each circuit shall be supplied individually, labeled, properly sized, protected from weather and sealed to be watertight.

8. ENGINE:

Automatic idle shutdown shall be set to five (5) minutes. An audible warning alarm and dash light shall be provided to alert operator prior to engine shutting down.

ECM shall be set to a maximum of sixty-five (65) miles per hour.

The engine components facing wheel areas, on both sides, and the areas to the rear of wheels shall be shielded. The shield shall protect the engine, fan, radiator, belts and areas behind tires from stones and debris.

Replaceable heavy-duty oil filter(s) as recommended by the manufacturer and **bearing a legible OEM part number**.

Diesel Fuel Filter: There shall be a DAVCO 382 or 487 filtration unit installed and mounted Higher than fuel tank per manufactures recommendations in a location to accommodate filter replacements, yet be protected from road debris **(No substitute, standardization)**. Mounting location to be determined at pre-build meeting.

Davco 382 Unit shall be equipped with engine coolant heat and 120 volt heater circuit. The 120 volt circuit and engine block heater shall be powered via the same electrical connection. **(No substitute, standardization)**

Davco 487 shall be equipped with a 12 volt and 120 volt heater circuit. 12 volt heater circuit will activate with the ignition key switch, the 120 volt heater circuit and engine block heater shall be powered via the same electrical connection. **(No substitute, standardization)**

Cooling System: The system shall be the largest factory engine cooling capacity, compatible with engines and transmissions referenced for continuous high engine output under extreme temperatures and/or operating conditions due to prolonged snow plowing operations in low gears. The water pump shall be adequately sized to provide proper cooling and be of sufficient size to accommodate the larger pulley to adequately handle the specified options. Shall be fitted with provisions for visually monitoring coolant without necessitating removal of the cap from the radiator or expansion tank (e.g. sight glass, transparent expansion tank). The antifreeze solution shall meet all applicable EPA requirements. A non-charged spin-on coolant filter shall be installed if required by engine manufacturer.

Cooler guard: Mounted in front of radiator, full width and length to protect from stones and road debris. System to be approved by engine and truck manufactures.

Engine Oil Pan: Oil pan shall be 304 stainless steel, with stainless steel mounting hardware. Stainless steel oil pan shall be compatible with the FLOCs fittings. Stainless steel oil pan shall not void OEM's warranty.

-14-
SPECIFICATIONS

AA1

I. GENERAL TRUCK SPECIFICATIONS: (Continued)

D. VEHICLE COMPONENTS: (Continued)

The oil dipstick must have tubing and dipstick with sufficient length to provide reasonable access for checking the oil level.

Engine Heater: Immersion in-block type, for cooling system, with waterproof plug, flush-mounted in an accessible location at the front/side of the vehicle, outside the cab/hood, 110 volt, 3-prong plug. The electrical cable from the heater to plug shall be one piece and waterproof. Location to be determined at the pre-build meeting.

Air Cleaner: Air filter shall be manufacturer's heaviest duty air cleaner that meets all the requirements of the extended engine warranty.

The air intake system shall be fitted with inside/outside air.

Fan: Thermostatically controlled viscous type or manufacturer's recommended automatic fan.

Screening system: Mounted in front of radiator that protects radiator full width and full length from stones and road debris. System to be approved by engine and truck manufacturer(s).

Engine Vibration Dampener: At PTO flange yoke. Ref: EQN-90.

Governor: Set at manufacturer's recommended maximum rpm.

Hoses: The air induction system and large radiator cooling system hoses shall be clamped with 0.500-inch-wide, 150-inch LB stainless steel, constant torque, spring-loaded worm clamps. Ref: Wittek Manufacturing (Tel: (312) 492-9400) or Breeze Clamp Co, Constant Torque clamps with liner for silicone hoses. Cooling system hoses under 1-inch OD may use factory standard hose clamps, as a minimum acceptable standard.

Air intake hoses shall be 0.250-inch minimum thickness, molded hoses. Ref: Gates, Goodyear or equal. Silicone or premium rubber, radiator and heater hoses. Hoses shall not be painted.

Lubricating Oil Lines: High quality flexible wire-braid type, "Aeroquip" or approved equal system, minimum standard if hoses are used.

Drive Belts: Cog belts or serpentine.

Engine Brake: Engine shall be equipped with a minimum 2 stage, full engine compression brake.

Brake lights shall activate when engine brake is activated, Ref: Jacobs.

9. EXHAUST:

Vertical tailpipe with elbow and muffler system or horizontal muffler and vertical tail pipe with elbow.

Exhaust system shall neither interfere with the operation of the dump body or equipment, nor shall it be close to any fluid tank, and **PERMIT WING PLOW AND PRE-WET TANK**

INSTALLATION. The tail pipe shall be installed in a manner that will keep the muffler and tail pipe away from dump truck body. The flex in the body, when operating on an uneven terrain, must be considered in the design.

The muffler, DPF and tail pipe shall be shielded or insulated to protect personnel from burns when entering or exiting the cab. The shield shall be 180 degrees to 360 degrees and shall be of non-rustable material such as stainless steel or aluminum.

All exhaust/DEF components shall be properly shielded to protect personnel from contact, at ground level to the side and rear of cab and normal entrance and exit into cab. Exhaust components below and to the inside of the frame rails do not need shielding. Awarded OEM Model will be discussed at pre-build.

10. FAST LUBE OIL CHANGE SYSTEM (FLOCS):

This FLOCS system shall be installed with all fittings, brackets, clamps and hoses. Hose from oil pan to FLOCS fitting shall be hydraulic hose with a 100R2 rating and properly secured. The system shall be compatible with all fittings presently used by the Department. The final placement of the male half of the snap coupler, on the equipment, shall be determined at the pre-build meeting. Ref: EQN-351A.

I. GENERAL TRUCK SPECIFICATIONS: (Continued)

D. VEHICLE COMPONENTS: (Continued)

11. FRAME AND FRAME EXTENSION:

Frame shall be a single rail; dual frame rails are unacceptable.

Resisting Bending Moment (R.B.M.) shall be a minimum of 2.5 million-inch LB per rail, including extension, for the entire length of the frame, including any frame liners. Where engine and radiator adjustments are required, a minimum of one million-inch LB per rail R.B.M. will be accepted.

Frame material shall be of at least 120,000-PSI yield strength. Minimum frame RBM shall be approved by manufacturer 's Engineering Department. **If a larger RBM is required to perform the specified operational duties, the vendor shall bid a frame concurrent with the intent**

and spirit of this contract. Ref: Snow removal operations, full payload snowplow, right and/or left patrol wing plow, etc. Mainframe and any required liners shall be either straight channel or offset channel, full length. **Bolt-on or welded extension will not be accepted.**

Front frame shall accommodate the Department's standard hydraulic PTO shaft and pump (Ref: EQN-90) and the plow frame. It shall provide easy service accessibility.

12. INSTRUMENTATION:

All instruments and gauges shall be illuminated and dash-mounted, except where specified otherwise.

All standard instruments shall be supplied, including, but not limited to the following:

Oil pressure gauge with warning light or audible alarm.

Air pressure gauge(s) for dual circuit, dual indicator with low-pressure audible alarm and warning light.

Coolant temperature with warning light or audible alarm.

Transmission oil temperature gauge with warning light or audible alarm.

Fuel gauge.

Hour meter that records only when the engine is running. In – dash, integral with instrument panel and readable from the operator's seat.

DEF level gauge.

Speedometer with odometer and a dual speedometer lead to interface with the ground speed spreader control system.

Low air pressure indicator: Buzzer-type and dash light. Must meet current Federal DOT guideline requirements. Air gauge shall display in 5lb. increments. Digital numerical readout is acceptable.

Air gauge and low air warning buzzer shall operate with key switch **on** and engine **off**. Function shall not have capabilities of being deactivated by the operator.

Tachometer.

Voltmeter.

Parking brake indicator light.

Hydraulic fluid level gauge shall be installed within the dash face, exterior installation will not be accepted.

Air Restriction Gauge: Vehicle OEM equipped electronic dash that incorporates an air restriction gauge or indicator light, shall be required.

13. PAINT:

Cab shall be painted with OEM manufactures standard painting process PENNDOT yellow Ref: DuPont F9885, PPG 85246, Sherwin Williams 73266, Sikkens 4017 and NAPA 73266 for shade only.

Entire cab except for glass, rubber and those metallic accessories or fixtures constructed of rust-resistant (Aluminum and Stainless Steel) or plated material not normally painted. Base coat and clear coat. Ref: Axalita Imron for durability

OEM frame manufactures standard procedures shall be acceptable, all underside and attached components shall be ground to eliminate weld splatter, scale, sharp edges, rust and oils prior to a rust preventive primer and top coat of black paint. Powder coating is acceptable. Rims shall be painted as specified in the tire and wheel section of this specification.

-16-
SPECIFICATIONS

AA1

I. GENERAL TRUCK SPECIFICATIONS: (Continued)

D. VEHICLE COMPONENTS: (Continued)

14. STEERING:

Power Steering: Dual integral type hydraulic power steering with right wheel power-assist cylinder. Glidecoat steering shaft or Bendix wedge lock lube-for-life shaft. The steering system (e.g. flow, pressure, relief valve etc.) shall be selected considering the full front-GAWR axle loading. Hydraulic supply pump shall be vane or roller type design with sufficient oil flow to permit one (1) steering wheel revolution per second with front axle loaded to rated capacity, with plow on, in a "park" condition. Ref: Vickers V-20, Eaton or Borg Warner. The pump shall not be the integral filter type unit. Power steering reservoir shall be remote mounted, minimum 1.5 -quart capacity, incorporating a filter that is easy to remove and replace. The remote filter referenced above shall be factory mounted, certified and engineering approved in conjunction with the appropriate pump.

15. SUSPENSION: FRONT:

10,000 LB capacity at ground, each front spring. The six (6) front spring pins or bearings/bushing shall be furnished with 360-degree grease grooves to insure adequate lubricant penetration. Spring hangers shall be heavy castings with sufficient pin and bearing surface to render trouble free service. Maintenance free front spring bushings are acceptable.

16. SUSPENSION: REAR:

23,000 LB capacity at ground, each rear spring. Suspension shall be tailored to axle loads and shall be adequate to sustain maximum GVW, without overload or permanent set. The spring hanger brackets shall be severe duty castings with sufficient bearing surface/wall thickness to prevent premature bolt wear. The spring center bolts shall be a minimum of .4375-inch size, preferably .5000 inch. The rear spring hanger pins shall be the greasable type. Bolts must be of sufficient length to go through the washer, spring bracket and truck frame with sufficient length to install a self-locking nut.

17. TANK - FUEL:

Safety- type fuel tank as per the requirements of FMVSS. Dual tanks are unacceptable. Trucks with no wing and trucks with a right wing shall have one (1) 100-GAL minimum total capacity tank, frame mounted, under the left door. Left wing and dual wing trucks shall have one (1) 80-GAL minimum total capacity tank, frame mounted, under the left door. Tank mounting hardware and brackets shall be for "severe duty" applications. Heavy-duty aluminum or stainless steel, minimum 1.9-inch wide straps with rubber shims/liners shall be utilized. The fill pipe shall be accessible with the dump body in the down position; pipe can be located at either end of tank to avoid interference with steps. System shall be a top or side draw for suction and return lines.

-17-
SPECIFICATIONS

AA1

I. GENERAL TRUCK SPECIFICATIONS: (Continued)

D. VEHICLE COMPONENTS: (Continued)

18. WHEELS/TIRES:

The truck shall be equipped with hub piloted steel disc wheels for tubeless tires. The wheel end shall be equipped with outboard cast brake drums, and 15-degree tubeless steel wheels, hub piloted, 10 hole - 285.75mm bolt circle with 22mm two-piece flange nuts.

Front: Wheels: 22.5 x 12.25, 10 hole - 285.75mm bolt circle with 220mm bore, tubeless steel disc wheel rated at 10,500 LBS at a maximum inflation pressure of 120 PSIG. Accuride part number 29807.

(No substitute, standardization).

Rear: Wheels: 22.5 x 8.25, 10 hole - 285.75mm bolt circle with 220mm bore, tubeless steel disc wheel rated at 7,500 LBS at a maximum inflation pressure of 120 PSIG. Accuride part number 28828.

(No substitute, standardization).

The dual rear wheel/tire assembly shall have clearance between the tires, which permits the use of dual tire chains.

Wheel-Guard Separators: The wheel ends shall be equipped with the Accuride part number 5903

Wheel Guard Separator as follows:

Front axle - between the wheel and the brake drum.

Rear axle - between the inner dual and the brake drum and between the inner and outer duals.

Paint: The wheels shall be topcoat painted with TGIC Polyester Powder Paint MLD-82008 High Gloss Gray or equal applied over Cathodic Electro-Disposition Gray Primer.

Tires: Drive tires shall be mud/snow tread. All tires shall be radials and have minimum 25/32 thread depth.

Front Tires: 425/65R22.5 (Load Range L).

Rear Tires: 12R22.5 (Load Range H).

MANUFACTURER

Goodyear

Michelin

Bridgestone

19. TRANSMISSION: See POWER TRAIN OVERVIEW for acceptable transmissions.

AUTOMATIC:

ALLISION 4500 RDS 6 SPEED

Automatic transmission cooler lines shall be stainless steel.

All vehicles shall have a transmission (auto) operated safety starting switch that will avoid engine starting with drivetrain in gear.

Dash mounted console with push button shift selector or steering column mounted stalk style selector.

An external, Allison approved cooling system shall be installed regardless of whether a full engine compression brake is incorporated in the system or not. The oil cooler for transmission is required due to prolonged transmission torque converter operation in low gears. Cooler shall be sized to keep the transmission fluid at an acceptable operating temperature under these prolonged conditions (Water to oil type cooler). Automatic transmission cooler lines shall be stainless steel, Braided hoses will not be accepted, and all hoses shall be routed to prevent rub-through with hanging brackets and P-style clamps.

Unit shall be programmed to require a service brake application for transmission to shift into any gear from neutral.

All transmission modules shall be routed and installed in the cab

-18-
SPECIFICATIONS
AA1

I. GENERAL TRUCK SPECIFICATIONS: (Continued)

E. DUMP BODY AND EQUIPMENT MANDATORY MINIMUM SPECIFICATIONS:

1. DUMP BODY STRUCTURE, STAINLESS STEEL:

Intent: The purpose of these specifications is to describe a conventional cab, tandem axle dump truck, equipped with dual rear wheels, 13.5-foot dump body, and 12 cubic yard approximate load capacity with either a **Front Center Discharge** or a **Rear Center Discharge**. 201 stainless steel body of a radius design, dual auger, underbody center mounted hydraulically adjustable directional spinner, hoist, hydraulic power system and snow plow hitch. The radius design shall provide consistent flow of materials to the dual auger without the need to raise the bed. It shall be capable of one-man operation while plowing snow and simultaneously spreading granular and liquid materials during winter operations (without the need to raise the bed), and of hauling, stockpiling and unloading maintenance materials into a chip spreader or paver during summer operations. Further, it shall be capable of being loaded with a front-end loader or self-propelled belt loader.

The body shall be reinforced to withstand SEVERE duty service and be capable of excavation with rip rap being dropped in the bed.

Body design, subframe and body mounting shall allow tire clearance with tire chains without contact to fenders or body.

There shall be a hydraulic lock out to the Floor Conveyor Augers when any of the following conditions exist. 1. Whenever the bed is raised. 2. The tailgate is unlatched to open. 3. Top Grate is opened or removed.

Samples of longitudinal and crossmember extrusion shall be supplied prior to build with lb./ft rating information for approval prior to pilot model build.

Pennsylvania Department of General Services, PCID No. 1075, "*General Requirements for Bidding PennDOT Vehicles/Equipment*", most current version effective at the time and date of bid opening is included as a part of this specification. PCID No. 1075 may be reviewed and downloaded from the Department of General Services website, <http://www.dgs.state.pa.us>. Delivery as required per Department of General Service PCID NO. 1075 Section "G". All units must be delivered within **300** days after receipt of the purchase order by the successful bidder.

Awarded OEM vendor shall be responsible for contacting the Specification Section of the Fleet Management Division at (717) 787-1567 to set up a pre-build meeting for all chassis and body mounting component locations prior to chassis build. Any deviations to the specification must be granted in writing by the Chief of the Specification Section. It shall be understood that any discrepancies/deviations between the specification and the completed unit(s), chassis or body up-fitter related, must be addressed and corrected prior to the delivery deadline and the Departments acceptances.

Unit shall be delivered with current PA state Inspection and a full tank of fuel.

All component manuals and weight distribution sheets shall be completed and supplied with the Pilot unit and the subsequent delivery of each unit.

-19-
SPECIFICATIONS

AA1

I. GENERAL TRUCK SPECIFICATIONS: (Continued)

E. DUMP BODY AND EQUIPMENT MANDATORY MINIMUM SPECIFICATIONS: (Continued)

1. DUMP BODY STRUCTURE, STAINLESS STEEL: (Continued)

Body Guides: There shall be stainless steel body guides mounted to the longitudinal beams (both sides). There shall be mated stainless steel reinforced guides bolted to the truck frame. Stainless steel guides shall be constructed using minimum 1/4 inch stainless steel.

Body Sides: Shall be constructed using a minimum of 3/16 inch 201 stainless steel and be a minimum of 36 inch high from top of bed floor to top of bed rails (one piece per side) and of a radius design to allow flow of material to the auger trough. Top rails shall be 4 inch boxed 201 stainless steel, continuous welding. Top rails shall be one-piece construction: NO SPLICING. Body width shall be 96 inches. There shall be integral side fenders fabricated from a minimum of 3/16 inch stainless steel, both sides of the body and full length of the body. These fenders shall slope away from the body to prevent excess material from building up on them. There shall be stainless steel gussets for side boards mounted to the top rail front, mid and rear. There shall be 2 inch by 6 inch, full length, rough oak side boards securely installed on both sides. A 3/8" pipe fitting with removable threaded plug shall be installed in the center line of the body approximately 12" from the floor level to allow temperature checks of hot asphalt. Threaded plug shall have three (3) inch bar stock welded for handle and be tethered to the bed to keep it from becoming separate from the truck. Ref: EQN-79AF

Shovel Holder: There shall be a Buyers stainless steel shovel holder model SH675SS (No substitute) welded to the curb side of the body, hook to hold shovel in upright position shall be located above to accommodate up to a 51-inch shovel handle (location of holder to be determined at the pre-build meeting) Ref. EQN-557 & EQN-79AF

Steel Body Props: There shall be two (2) props, (one per side) welded or bolted to the long bed beam. There shall be a three (3)-pocket rest bolted to the truck frame rail on each side. When released from the cradle, the body props shall be free to fall. Props shall fall into step retainer as bed is raised, un-assisted. Ref: EQN-62.

Floor / conveyor: **Front Center Discharge** or **Rear Center Discharge** There shall be an integral material conveyor consisting of two 7-inch diameter counter rotating augers (Augers shall be variable pitch flighting) that are centered and recessed along the full length of the floor. Outer circumference of augers shall be hard surfaced continuously. The conveyor trough shall be one-piece construction utilizing 3/16-inch 201 stainless steel and designed to allow uninterrupted flow of material to material chute. Each auger shall be powered by a separate hydraulic motor/gear box combination to work in unison to provide calibrated flow range of material between 100 pounds pre lane mile to 800 pounds per lane mile. The opposite end of auger shall have greasable heavy duty flange bearings and shall be connected to the trucks on board grease system. There shall be a conveyor cover fabricated from 3/16-inch AR400 to cover the conveyor for normal dump body operation and shall be secured as to not allow material build up in the conveyor trough. The floor / conveyor shall be designed to not allow material to fall on chassis components. There shall be an anti-flow plate located at the discharge end of the trough to prevent flow by of material when conveyor is not running.

Spinner Assembly: **Front Center Discharge** or **Rear Center Discharge** There shall be an underbody center mounted hydraulically adjustable directional spinner to spread the material discharged from the floor auger conveyor. Spinner assembly shall be manufactured from 304 stainless steel. Spinner shall be adjustable to allow proper positioning under material chute. The spinner system shall be capable of being adjusted electronically in the cab on the spreader control console to spread from 1 lane left, center, or right, 2 lanes left, center or right: or up to 3 lanes at one time. Spinner discharge shall be hydraulically adjustable from left to right (Minimum 170 degrees) from within the cab and be controlled by the central hydraulic system. Spinner discharge shall be controlled by a hydraulic cylinder and the rod shall be nitrated. Spinner assembly shall be easily removable for summer operations.

-20-
SPECIFICATIONS
AA1

I. GENERAL TRUCK SPECIFICATIONS: (Continued)

E. DUMP BODY AND EQUIPMENT MANDATORY MINIMUM SPECIFICATIONS:

1. DUMP BODY STRUCTURE, STAINLESS STEEL: (Continued)

COUPLERS: One (1) 1/2 inch spinner – 5600-series-10 (Pressure Female Coupler) no substitute.

One (1) 1/2inch spinner – 5600-series-10 (Return Male Coupler) no substitute

Hydraulic couplers shall be stainless steel.

All necessary hardware and fittings shall be supplied to ensure that the system is fully functional.

Material Chute: **(Front Center Discharge Only)** There shall be a 304 stainless steel material chute that is engineered to transfer winter materials from the floor auger conveyor to the spinner assembly. Chute shall be securely mounted under the bed auger opening, to pass to the driver's side allowing clearance of the chassis driveshaft and engineered as to not interfere with any driveline components under any load situation. Rear discharge shall be in the center. Chute shall be engineered to not allow any material spillage. Material chute shall not interfere with summer operations.

Underbody Chassis Shield: **(Front Center Discharge only)** shall have an underbody chassis shield to protect the chassis components from winter materials being dispensed from the spinner assembly. Shield shall be engineered to deflect material toward the road surface. Shall be constructed of 201 stainless steel and be securely mounted to the chassis, but easily removable for summer operations.

Front Body Bulkhead: One-piece design fabricated from one-piece of minimum 3/16 inch 201 stainless steel, radiused and fully welded to the body sides, shall be 60 inches from top of conveyor to top front panel. Body front panel shall be completely clear of any type of recesses and or protrusions into the body area. There shall be a hoist mount on the front (cab side) of the front panel for the upper mount of the telescoping lift hoist.

Rear Corner Posts: Shall be constructed using 3/16 inch 201 stainless steel, both shall be full depth one-piece construction from the top of the tailgate to the bottom of the rear bolster and shall be free of holes. There shall be two-spreader chain holders on each rear corner post (top and bottom banjo style) fully welded. Final location to be determined at pre-build meeting.

Cab Shield: One-half (1/2) cab shield constructed using 201 stainless steel with a 4 inch formed front face extending over the cab. There shall be a minimum of four (4) fully welded stainless steel braces that extend from the front lip of the cab shield back to the 4 inch channel at the rear of cab shield.

Tailgate: Double acting three-(3) panel tailgate shall be manufactured using 3/16 inch 201 stainless steel and shall be a minimum of 48 inch tall. All bracing shall be stainless steel. There shall be an inverted angle on top of the tailgate constructed using 1 1/2 inch stainless steel or approved equal dirt sheading design. There shall be two (2) "J" hooks welded to the tailgate as chain holders. There shall be two (2) 3/4 inch stainless steel round stock hand holds welded to the gate. There shall be four (4) tailgate chain brackets fully welded to the tailgate, two (2) on each side. The spreader chains shall be 3/8 inch and covered with black expandable braided sleeving monofilament. Tailgate latch pins shall be 201 stainless steel a minimum of one (1) inch diameter. Welded and of sufficient length to support the tailgate in the closed position when the bed is fully loaded. Conspicuity required on the tailgate, Ref: EQN-122 & EQN-561

Tailgate Hinges: Shall be Stainless steel construction severe duty attachment brackets with replaceable heavy-duty bushings. Pins and or Hinges shall be greasable. Both hinge pins shall be a minimum of 1.25 inch with a tapered end and sufficient length for easy removal. Both pins shall be chained to body and of non-rotating design.

Tailgate Latches: Shall be of steel construction, grade 50 high tensile material and mill certified, bolted into the rear corner post and grease able. Air operated tailgate shall be a spring-over-air system and fail in closed position. The actuator shall be an AIRman Tailgater B300-259-H5. **(No substitute, standardization)**. Pneumatic tailgate switch shall be mounted within the central hydraulic console. Shall be dual linkage design, with a greasable cross over shaft. All air piping and connections must be D.O.T. approved, with minimum 0.25 inch nylon tubing and brass compression fittings. **Note: Tailgate hinge and latch design shall be approved prior to build.** Ref: EQN-78A & EQN-1105

-21-
SPECIFICATIONS

AA1

I. GENERAL TRUCK SPECIFICATIONS: (Continued)

E. DUMP BODY AND EQUIPMENT MANDATORY MINIMUM SPECIFICATIONS: (Continued)

1. DUMP BODY STRUCTURE, STAINLESS STEEL: (Continued)

Wheel Chocks: There shall be a pair of wheel chocks with holder/s (location of holder to be determined at the pre-build meeting) As per EQN-82B.

Top Grate: There shall be a top grate covering the entire top of the bed area. Grate shall be severe duty to withstand salt, anti-skid or any combination of materials being loaded into bed. Grate shall be constructed from a minimum of 3/8 inch steel rod welded together to form 2 1/2 inch squares, plus or minus 1/2 inch. Grate shall have a non-freezable hinge point that runs front to rear. Top grates shall be a minimum of four sections. The entire top grate shall be removable in one piece and shall incorporate balanced lift points for removal. Grate shall be properly prepared, and powder coated black. Grate shall be designed to work in conjunction with installed tarp system. The grates shall incorporate a safety lock system to prevent easy access to bed area. Safety lock system shall disable floor augers, bed operation shall remain operatable. Ref: Automation direct inductive proximity sensor PN# PMW-OP-2H wired with harness PN# EVT221. **Design of safety lock system shall be approved by the Fleet Management Division prior to construction.** Ref: EQN-79AF

Bed Speed requirements:

Bed speed shall be tested at 1500 rpm at normal operating temperature.

Bed speed full up shall be 20 seconds maximum.

Bed speed full down shall be 25 seconds maximum.

Hoist Cylinder Mounting: The hoist cylinder shall be mounted to an upper & lower heavy-duty hoist mount with minimum 2 inch diameter pins and 2.125 inch x 1/2 inch greasable wall bushings shall be used. Note: the base shall be fabricated (no bolt together or cast mounts). There shall be a remote grease hose and fitting to all cylinder grease points. Hoses shall be installed to sufficient length and protected from rubbing and chaffing. Location of fitting to be determined at prebuild meeting.

A Mailhot Trunnion mounted cylinder shall be acceptable meeting the same criteria.

Hoist cylinder shall be front mounted (externally) with no "Dog box" inside the bed.

Hitch Assembly: Pintle plate shall be made using 3/4 inch steel. It shall be inserted within the frame rails, with sufficient clearance for body dump pin. Frame rails shall not extend beyond the hitch plate. It shall extend the full width of frame rails and extend a maximum of 5 inches below the frame rails. The lower portion of the plate shall be channeled towards the front of the vehicle, with proper gussets added between frame rails and plate. There shall be two (2) safety chain D-style rings 0.750 diameter with a minimum breaking strength of 53,000 LB mounted to the plate each equal to the hitch rating (Ref: Ken Forge PN# 797. There shall be a trailer break away ring securely fastened to the plate on the left side of the pintle for attaching a trailer breakaway cable. The plate shall be placed 5 inch +/- 1 inch from the edge of the rear tires. End of bed to rear of rear tire 19 inch +/- 1 inch shall still be obtained. Ref: EQN-79AF

Pintle Hook: There shall be one of the following manufacturer's 25-ton pintle hooks with spring loading, swivel design mounted to the hitch assembly, Wallace Forge 2044101 or Buyers BP200. Pintle hook mounted as Ref: EQN-79AF.

Rear Light Module: The rear light module shall be integrated into the Hitch assembly containing the following components:

-22-
SPECIFICATIONS
AA1

I. GENERAL TRUCK SPECIFICATIONS: (Continued)

E. DUMP BODY AND EQUIPMENT MANDATORY MINIMUM SPECIFICATIONS: (Continued)

1. DUMP BODY STRUCTURE, STAINLESS STEEL: (Continued)

All lighting shall be LED. Module construction shall be a minimum 0.250-inch thick steel and shall be fully enclosed to eliminate material entering housing. License plate and license plate lamp shall be surface mounted with a 1 1/4 inch protective shield welded along the top and both sides to protect the plate and light from damage. All electrical connections shall be made within the sealed module and powered through the original chassis harness, with a compression fitting used at the wire pass-through location which shall be at the bottom of the module and configured in such a way that water cannot wick from the wires into the module. A small 1/4 inch hole shall be drilled on both the left and right bottom corners to drain any water that may enter the module. All electrical connections shall be weather tight and sealed with heat shrink, all open connections within a sealed box shall be coated with di-electric grease. Component placement on the module as per EQN-79AF.

Wiring Pass Through: All wiring entering the cab shall be made through a rubber boot assembly and be weather tight. There shall be no connectors in the wiring at the pass-through point. Wiring shall be protected against sharp edges and from rubbing/chaffing. Boot design shall be pre-approved.

- (1) One grommet mounted back-up alarm, Ecco model 450. **(No substitute, standardization)** Alarm shall be mounted as high as possible, without obstruction within the rear module plate.
- (1) One license plate lamp, Trucklite Model 36140C. Shall be shielded with license plate. EQN-79AF
- (2) License plate mounting holes, with stainless steel hardware included.
- (1) One Pin Type 7-way female electrical trailer plug connection. Ref EQN-80A
- (1) One 3-lamp cluster. Trucklite Part # 33740R **(No substitute, standardization)**

Body Lighting System: Whelen model # 01-1518839-13B, to include the following, model number will assign cable length and light mounting material for body configuration. Ref: EQN-79AF A six to eight-week lead time is required for delivery of light kits Whelen contact is Brad Walker (740) 325-6727 or bwalker@fleetreps.com

- 4-Headboard Warning 01-026F523-A0
- 2-Reverse Light 01-066G397V11
- 2-Brake/Tail 01-066E462-R1C
- 2-Rear bed warning 01-026F769-A0
- 2-Side Rear Warning 02-0363818-10C
- 1-Photo Cell 01-066D205-010
- 1-Spreader light 01-0686447-30F
- 1-Flasher Model #SLFLASH
- 4- Red 01-02634898R90
- 2-Amber/Yellow 01-02634898A90

Kit to include wiring (installed in body) and diagnostic board (installed in console) for Snow Away heated tail light lens. Heated Lens will **not** be included in build.

- * Depending on wing configuration, illumination light 01-0418169-01F shall be installed for each wing installed
- * Depending on wing configuration, steady "RED" light 01-066E765-500 shall be installed for each wing in conjunction with a mercury switch (mercury switch not supplied from Whelen).

All amber warning flashers shall be connected to dedicated OEM dash switch.

Wing illumination light(s) shall be connected to dedicated OEM dash switch.

Spreader illumination light shall be connected to dedicated OEM dash light.

Plow lights shall be connected to dedicated OEM dash switch.

-23-
SPECIFICATIONS

AA1

I. GENERAL TRUCK SPECIFICATIONS: (Continued)

E. DUMP BODY AND EQUIPMENT MANDATORY MINIMUM SPECIFICATIONS: (Continued)

1. DUMP BODY STRUCTURE, STAINLESS STEEL: (Continued)

Whelen control panel shall be mounted within the cab under passenger seat with access cover facing passenger door for easy accessibility. Whelen light kit shall include a programable flasher that turns both the rearward facing yellow strobe lights off when the turn signal, four ways and brake lights are on, then returns to normal operation. System shall also be equipped with a photo cell mounted to the right side in the chassis cab forward facing on the A-pillar that will dim all the flashing yellow strobe lights at night and return to full power in the daylight. Reward facing light modules shall be configured and provided with heated lens covers. Heated tail light lens fault light shall be mounted inside the cab, central hydraulic controller dash viewable from driver's position. Flasher module is to be fully programable with department software provided by Whelen for any combination of flash pattern. Brake lights shall operate when engine compression brake is activated.

Whelen light package shall be installed and wired so the 4-way flasher and amber lighting to continue working after engine 5 min. shut down activates. All circuits shall be individually labeled with permanent labels.

All open terminal connection shall be coated with 3M brand Scotchkote Electrical Coating FD.

All OEM connections within the battery box shall have attached non-metallic embossed labels/tags. Labels/tags applied with self-adhesives or stickers will not be accepted.

Any circuit deemed necessary for connection in the battery box by the body up-fitter or component manufacturer shall have attached non-metallic embossed labels/tags. Labels/tags applied with self-adhesives or stickers will not be accepted.

Chain Boxes: Shall be aluminum with safety grating overlaid.

There shall be a minimum of four (4) 3/4 inch drain holes in the box floors. Final position of these boxes to be behind the swept back front bumper and outboard of the frame channels, flush and level with top of bumper.

Chain boxes shall be mounted with a one (1) piece formed channel, minimum 0.250 thick steel. Formed channel shall have a minimum 3 1/2-inch flange attached to the plow frame with full weld, flange shall taper to a minimum of 2 inch at end of chain box. Formed channel mounting bracket shall be full width and end flush with outside edge of chain box.

Chain box hinge shall be full width solid round stock with a heavy wall pipe stock welded hinge and nylon bushed.

Chain box rubber latch and catch shall be installed with flush rivets. Machine screws with nuts will not be accepted.

Note: two (2) boxes with no wing, one (1) with left or right wing, zero (0) with dual wing applications.

Ref: EQN-32.

Splash Guards: Both front and rear splashguard assemblies shall be stainless steel and properly braced. Ref: EQN-66.

Rear: Stainless steel splashguards shall be attached to the dump body on each side, behind the rear-most dual wheel, and extend downward to accommodate a 30-inch or 36-inch flap in order to meet Pennsylvania State Inspection Requirements. Mud flap sizes permitted are 30 inch or 36 inch. **(No substitute, standardization)**. The rubber splashguards shall be bolted to these metal splashguards using self-locking nuts and metal strips. Flaps shall meet Federal Regulation of 22 degree. Flaps shall be heavy duty anti sail/anti spray and be razor split.

Front: The forward splashguards shall be stainless steel and extend downward 3/4 of the length of the rear splash guard/mud flap, with a 1/4 inch length, unmarked mud flap attached for the remaining distance. Forward splashguard shall have a 1-inch lip for entire length-outside extremity (90 degree) with bottom outside corner rounded and have rolled edges. Splashguards shall be full length and width with no holes cut in it to accommodate salt lights.

Spray Suppression: Spray suppression shall be installed full length between front and rear splashguards (both sides). It shall be bolted/screwed to the body. Ref: EQN-79AF.

-24-
SPECIFICATIONS
AA1

I. GENERAL TRUCK SPECIFICATIONS: (Continued)

E. DUMP BODY AND EQUIPMENT MANDATORY MINIMUM SPECIFICATIONS: (Continued)

1. DUMP BODY STRUCTURE, STAINLESS STEEL: (Continued)

Pre-wet: Twin 190-gallon minimum poly tanks and plumbing kit with stainless steel tank enclosure and mounting hardware. Pre-wet tanks shall be securely mounted inside of the integral body side fenders one tank per side. Pre-wet tanks mounted to chassis mounted fenders shall be acceptable. Pre-wet tanks shall empty simultaneously from each tank. Final mounting location shall be determined at pre-build meeting. Pre-wet liquid supply line shall be plumbed to and installed to the spinner assembly. Tank fill shall be at ground level utilizing a two-inch male cam lock fitting with dust cap. Prewet pump shall be an Oberdorfer part # 25-N4000-RS3-02, Pump shall be driven hydraulically via a love joy connection. Hydraulic motor / pump assembly shall be housed in a NEMA enclosure large enough to facilitate servicing of unit, an electronic flow meter shall be installed to properly calibrate prewet. There shall be a low-level switch to automatically shut down the prewet motor when empty and an indicator to the operator shall be supplied. Location of prewet enclosure to be determined at prebuild meeting. Prewet pump shall have a flushing system utilizing a common garden hose. Each tank shall include an anti-splash vent tube mounted at the highest most point of the tank and shall have a non-collapsing hose plumbed (P type clamps shall secure hose at 12-inch intervals) to below the frame rail of the truck. All hose connections shall utilize appropriately sized worm type hose (screw) clamps. There shall be no lids or unsealed opening in the tank that could allow the unintentional release of liquid. All valves and filters shall be placed in a location outside of the frame rail and away from the possible release of liquid onto any part of the truck or components. Final location to be determined at pre-build meeting.

Bed Access Ladder: Folding ladder shall be welded to left front side of body, next to left front corner post. Ladder material shall be aluminum or 201 stainless steel, to match body material. Folding half of ladder may be aluminum to provide a lighter design. Handles shall be incorporated into design to provide operators handholds for folding, unfolding and climbing ladder. Ladder rungs shall be of an open design with a serrated edge in lieu of smooth edge. Top of first step shall be 21- inch from ground level, and rungs shall be evenly spaced at approximately 12 inch. Ladder design and mounting shall provide space for operator footing past ladder rung before contacting body side. Folding ladder shall provide a 15-degree angle from side line of body. Folding section shall have two (2) positive slotted/sliding locks, one to each side. Design shall be self-locking without the use of additional spring or rubber locking devices. Inside of dump body shall have grab handle installed in the upper rear side board pocket in line with outside ladder. Two (2) steps inside dump body for single axle, single axle crew cab and tandem evenly spaced in line with outside steps. Open design serrated steps shall be welded to body side minimum 13 inch to a maximum 16-inch-wide and 4.5 inch away from body side. All handles shall be coated with anti-slip paint, anti-slip tape will not be accepted. Completed ladder and grab handle design shall provide a minimum 500 lb. weight rating. Ref. EQN-79AF & EQN-1090

I. GENERAL TRUCK SPECIFICATIONS: (Continued)

E. DUMP BODY AND EQUIPMENT MANDATORY MINIMUM SPECIFICATIONS: (Continued)

2. CENTRAL HYDRAULIC CONTROL:

Hydraulic Control Approved Manufacturer's:
Certified Cirrus XDS.

Intent: The purpose of these specifications is to describe a conventional cab, tandem axle dump truck, equipped with dual rear wheels, 13.5-foot dump body, and 12 cubic yard approximate load capacity with either a **Front Center Discharge** or a **Rear Center Discharge**. 201 stainless steel body of a radius design, dual auger, underbody center mounted hydraulically adjustable directional spinner, hoist, hydraulic power system and snow plow hitch. The radius design shall provide consistent flow of materials to the dual auger without the need to raise the bed. It shall be capable of one-man operation while plowing snow and simultaneously spreading granular and liquid materials during winter operations (without the need to raise the bed), and of hauling, stockpiling and unloading maintenance materials into a chip spreader or paver during summer operations. Further, it shall be capable of being loaded with a front-end loader or self-propelled belt loader.

Intent/Installation Practices: The pressure compensated, load sensing central hydraulic system shall operate all functions (plows, dump body, dual auger spreader conveyor, hydraulically adjustable directional spinner, and pre-wet circuits) from an electric/hydraulic system independently and simultaneously, without interruption of any other hydraulic functions.

All controls and components shall be of the latest design and installed to provide simple and convenient operation.

All system operations shall be achieved from a single pump matching all required flow and pressure demands.

Hydraulic tool operation shall be included through both spreader circuits and will not require any type of cooling.

This system shall provide the most fuel efficient, safest, simplest and consistent operation possible.

All hydraulic components shall be installed and serviced by a single manufacturer.

Full responsibility for a serviceable system lies with the successful bidder.

All wiring shall be securely clamped at approximately 12-inch intervals, shielded from exhaust and include a protective sleeve where necessary to prevent damage and/or failure.

Upon start up, the hydraulic system shall be operated at maximum flow for not less than 15 minutes and then have a new hydraulic filter installed on the truck. Used filter is required to be placed in a leak proof bag and delivered with the truck to which it was removed from for proof that it was changed after the 15-minute break in period.

It shall be the sole responsibility of the successful truck manufacturer and Certified Cirrus to ensure that the chassis and the ground speed control wiring harness is totally compatible.

There shall be a hydraulic lock out to the Floor Conveyor Augers when any of the following conditions exist. 1. Whenever the bed is raised. 2. The tailgate is unlatched to open. 3. Top Grate is opened or removed.

I. GENERAL TRUCK SPECIFICATIONS: (Continued)

E. DUMP BODY AND EQUIPMENT MANDATORY MINIMUM SPECIFICATIONS: (Continued)

2. CENTRAL HYDRAULIC CONTROL: (Continued)

Seat Safety Switch: Drivers seat shall be equipped with a factory safety switch to work in conjunction with the central hydraulic system. Switch shall be rated at 7 lbs. and shall allow operation of the hydraulic spreader auger, spinner and pre-wet system when occupied and shut down the hydraulic spreader auger, spinner and pre-wet system ONLY when unoccupied.

Seat switch shall have all necessary components and connections to delay seat switch deactivation of auger spinner and pre-wet circuit ONLY for a minimum of five (5) seconds and maximum ten (10) seconds.

Deactivation of the seat switch system shall activate a message on the spreader control screen display "AUGER & SPINNER STOPPED", this feature shall not cause any other interruptions or faults in the hydraulic/spreader system.

Reactivation of the seat switch system shall not require any action or input from the operator for operation of the complete hydraulic/spreader system.

It shall be the sole responsibility of the OEM to ensure seat safety switch compatibility with the selected hydraulic system manufacturer control system. Aftermarket installation of this switch is unacceptable.

All electronic control modules and their connections shall be mounted within the cab in a location to provide access for servicing and to prevent damage / corrosion to modules and connections. Location to be determined at pre-build meeting.

System Operation: The system shall communicate over a CAN Open system bus using CAN Open protocol and not a proprietary communication protocol. The system shall consist of four primary modules that reside on the Bus and allow flexibility in mounting configurations. The system shall be expandable and allow for additional modules to be added to the CAN Bus. All four primary components of the system shall be software upgradeable using a laptop and interface cable or a USB thumb drive. The configuration file of a calibrated system shall be saved for transfer to other systems or as a backup providing the ability to use specific configurations for varying vehicle use or operator skill level. The original configuration file shall be maintained at the factory as a secondary backup and is traceable by part number. The in-cab control system panel shall be contained in an enclosure and mounted in an easily accessed position in the cab.

Control System Requirements: Central hydraulic system shall be capable of the following requirements in their entirety.

- All functions shall be recorded, and time stamped, to include capturing all error messages.
- System shall allow data to be downloaded in a common format (Excel).
- System shall be ground speed controlled and shall respond at one MPH.
- System shall have multiple level security and be individually password protected; Administrator and Technician. Operator shall not require a password to access the system and switch between automatic and manual operation.
- System shall be calibratable to various pounds per lane mile.
- System shall capture and store storm totals by event (Event Log).
- System shall capture and store annual storm totals.
- Stored data shall be capable of being cleared at various levels of password protection.
- System shall be programmable to a minimum of six material types.
- Materials shall be programmable to various weights.
- System shall have a programmable minimum / maximum setting for the auger and spinner.
- System shall have a feeder (Auger) sensor, and capability of turning the sensor on or off.
- System shall have a directional spinner location sensor that is programmable to various settings and will control and display spinner direction in the cab.
- System shall have a gate control sensor that is programmable to various settings.
- Each unit shall be capable of having an individualized seven-digit equipment number stored for identification purposes.
- System shall have a programmable prewet maximum / minimum settings at one-gallon increments and capable of being set to various gallons per ton of dry material.

-27-
SPECIFICATIONS

AA1

I. GENERAL TRUCK SPECIFICATIONS: (Continued)

E. DUMP BODY AND EQUIPMENT MANDATORY MINIMUM SPECIFICATIONS: (Continued)

2. CENTRAL HYDRAULIC CONTROL: (Continued)

- System shall be capable of showing auger jam
- System shall be capable of working in conjunction with the following products;
 - Wojanis hydraulic plow balance valve (plow saver)
 - Vasila and Road Watch road temperature sensor
 - Prewet flow meter
 - OEM installed seat switch
 - Current AVL system
- System shall have a manual override in the event of sensor failures.
- Shall be capable of operating when truck is moving in forward and reverse directions.
- Each hydraulic valve section shall have individual overrides located at each valve section.
- No tools shall be required to calibrate the system.
- Shall be equipped with a pause button to disable the system momentarily.
- Shall be equipped with a blast button to allow full calibrated material to be dispensed.
- Shall be equipped with an auger reversing switch located in the hydraulic controller dash panel.

Console Assembly: Shall be ergonomically designed for easy accessibility for operator from the driver's seat. Assembly shall be secured to the floor of truck as to not interfere with any original truck manufacture equipment. **Assembly shall be properly braced as to not allow any excessive movement that could be detrimental to the integrity of the floor or mounting location.**

Console shall have a padded arm rest and be adjustable to accommodate various operators' side to side and with three (3) inch adjustment down from a top height of 30 inch with positive locking. Console shall be capable of housing all hydraulic controls and switches, including all wing options and tow plow functions. Console base shall be of steel construction conforming to drawing EQN-509 or prior approved equal. Base shall include an adjustable bracket for mounting of state radio. Ref: EQN-509.

Display: The display shall be manufacturer's latest design and largest available screen, with backlighting, user adjustable positioning. The display shall be user resizable to provide maximum readability with varying display content including a status window that provides the operator with system status messages. The display shall incorporate "touch screen" switches that are defined by the system program via the display. When configured, the display shall incorporate granular rates, pre-wet rates, directional spinner position, road/air temperature, hydraulic pressure where designated, system status, error messages, plow float indication, auto/manual mode indication and material currently being used. Active functions that are not in use shall show "off" and the graphic be "grayed out" for ease of operator interpretation.

Display shall not emit "RF" frequencies or any "noise" that could interfere with any wireless or communications device utilized in any PennDOT vehicle such as a two way radio, CB, Cellphone or other communications device.

Consideration should be made when mounting display screen as not to block operator vision to passenger side mirrors.

Software: The system shall incorporate three levels of security and access that is password protected and defined by the user. The three levels of access called operator, technician and administrator shall give the user varying levels of access to system setup, data configuration fields and parameters based upon access given. The "administrator" shall have full access to all menus in the system and have the ability to make system configuration changes as well as system parameter changes. Spreader and liquid functions, when controlled utilizing closed loop feedback, shall incorporate an "auto trim" feature that will allow the system to automatically set the PWM minimums and maximums when engaged. The system shall have "over speed" protection for the liquid functions that will alert the operator and shut down the liquid function when the driver has exceeded a user defined speed. The software shall incorporate a "test speed" mode for use in testing the system safely without requiring the truck to be moving or the drive axles engaged.

-28-
SPECIFICATIONS
AA1

I. GENERAL TRUCK SPECIFICATIONS: (Continued)

E. DUMP BODY AND EQUIPMENT MANDATORY MINIMUM SPECIFICATIONS: (Continued)

2. CENTRAL HYDRAULIC SYSTEM / HYDRAULICS: (Continued)

Control Console: The control console shall contain individual joysticks to control hydraulic functions including tow plow and wing options. Body hoist stick shall contain an interlock button to protect against unintended operation. The plow stick shall be a two axis joystick. All joystick functions shall be protected by software based safety system to protect against unintended operation due to a joystick failure. The console shall contain the operator interface for the spreader control, joysticks, low oil override switch, plow balance control switch, wing float control switches, tarp switch, body up indicator light, directional switch for spinner and switch to control monetary reversing of the main augers during a "jam". All controls shall be securely attached, within easy reach of operator and console mounted. All controls shall be connected to the valve/s via an electronic cable and utilize CAN network communications. Console base shall be of steel construction conforming to drawing EQN-509. Base shall include an adjustable bracket for mounting of state radio. Ref: EQN-509. Unit shall be capable of adjustment vertically and horizontally to allow for comfortable positioning for the operator. **Console base shall be properly braced to eliminate floor flex.** Additional supports brackets shall be vendor's responsibility.

Wire Harness Kit: All wiring for the kit shall be included and be TPE type wiring only to the following specification: Wiring and harness system shall meet ISO rating IP68 and NEMA 6. The connectors shall be zinc die cast E-coated, similar to a MIL spec connector. Each shall have three sealing points- the lock ring itself, a raised portion of the molded plastic around each pin, and a viton O-ring that seals the entire connector. The cable jacket shall be TPE- thermoplastic elastomer and molded to the connectors. Connectors and harness shall be rated and tested for a temperature range from - 30C to + 70C. Connectors shall be tested to be water tight when submerged in 6' of water for 24 hours, in 275' of water for 1 hour, and when subjected to a 1000-psi pressure wash. The connectors shall be designed to have NO corrosion after 500 hours in a 35C salt spray. Cabling shall be rated excellent in low temperature flexibility and in its resistance to oxidation, heat, oil, weather, sun, ozone, abrasion, electrical priorities, flame, water, acid, alkali, gasoline, benzol, toluol, degreaser solvents, alcohol, and weld slag.

Combination Tank/Valve Enclosure: Combination tank/valve enclosure shall be frame mounted, in a location not to interfere with body, wing plow or exhaust components. Final mounting location shall be determined at pre-build meeting. Unit shall be constructed of ten-gauge 304 stainless steel. The oil reservoir portion shall not be less than 40-GAL capacity, filled with ISO 32AW hydraulic oil and a baffle plate to prevent oil flow from venting directly to suction port. Tapered outlet shall be below oil level at all times to prevent air entrapment. A magnetic drain plug shall be installed into reservoir. Tank shall be clearly labeled "**HYDRAULIC FLUID ONLY**". Lockable tank filler cap assembly, model 57XL-40 (40 micron with chain) L.C. as manufactured by Lenz. Tel: (937) 277-9364. An oil level sight gauge/thermometer shall be provided on the reservoir. A suction strainer shall be installed in the suction port of the tank. There shall be a provision for a low oil float to be installed. Low level float shall thread into the side of the assembly and shall have an M12 connector. The valve portion must be of weather-tight design and utilize a gasket to seal the lid to the body of the unit. Lid shall be retained by two rubber fasteners. Handles (two) shall be welded to the lid and constructed of stainless steel. A mounting location for the hydraulic control system module(s) shall be provided as part of the enclosure design. Stainless steel shields to protect exterior wiring shall be provided. The valve shall be installed in the enclosure by the hydraulic system supplier and pre-plumbed to the outside of the enclosure through the use of bulkhead style fittings. Enclosure shall provide space to service spool valve solenoids without removal of the hydraulic valve. No hoses shall enter the weather-tight area of the enclosure. Valve to be pre-wired inside the enclosure and **di-electric grease** shall be applied to all connections as required. Return oil flow shall be through the reservoir mounted filter assembly. Return filter shall be provided as part of the tank/valve enclosure assembly Ref: Fleetguard filter # HF302282 or equivalent **No substitute Standardization.**

SPECIFICATIONS

AA1

I. GENERAL TRUCK SPECIFICATIONS: (Continued)

E. DUMP BODY AND EQUIPMENT MANDATORY MINIMUM SPECIFICATIONS: (Continued)

2. CENTRAL HYDRAULIC SYSTEM / HYDRAULICS: (Continued)

It shall be rated @10 micron. There shall be a pressure switch with boot to activate a warning message on the control system screen. Cab mounted filter contamination indicator set at 23 PSI. Return filter housing shall have provisions for a service filter switch; connection shall be made via an M12 connector. Suction line/strainer shall have be 125 micron with 3 PSI bypass rated above 47gpm submerged at all times. Shall have a 1/4 turn, 2.5-inch full flow ball valve in the suction line as close to the tank as possible Strainer integral mounted in a 4-inch NPT female opening in the bottom of reservoir with a 3 inch female NPT opening. There shall be a 5600 series complete quick coupler (with dust cover) located in the pressure line entering the main valve assembly located inside the valve enclosure.

Quick disconnect shall be bracket mounted to the inside of the enclosure, easily accessible so that a shop pressure gauge (not to be installed or included) may be easily visible for test purposes. Final location shall be determined at the pre-build meeting. REF: EQN-508.

Wire harness covers shall be installed on the enclosure to protect the wiring harness where it enters/exits the modules.

Directional control valve: The hydraulic control valve shall be a Sauer Danfoss PVG32 with aluminum manifold to control spinner and prewet functions. (One Manual control lever is to be supplied per unit to control manual override of valve.) There shall be stainless steel threaded access plugs for access to load sense reliefs.

Sections shall be provided as follows: (non-wing)

Body hoist – PVG 32 Turbo Spool (34 GPM) section, double acting with 1500 psi down relief and 2000 psi up relief.

Plow raise/lower, double acting.

Plow angle, double acting, motor spool.

Dual auger floor conveyor, double acting, motor spool. Dual auger floor conveyor shall be reversing. Reversing valve shall be properly sized for system flow requirement.

Return manifold: There shall be a return line manifold mounted on the chassis, location to be determined at the pre-build meeting. Ref: EQN-94. Return manifold shall be an 8-port header block with 8 # 16 SAE openings and 2 #24 SAE openings at each end. Header shall be an Alamo, Damon or Hycoa or equal.

There shall be a 3-port valve block to control spinner, auger, and pre-wet as part of the main valve assembly. There shall be two (2) return lines from the control valve to the return manifold.

Body Limit Alarm System: Switch shall inform the operator by an illuminated console mounted light. An audible alarm (Steady Buzzer) Ref: Floyd Bell part # TMC-V86-948-Q shall be installed (**No substitute, standardization**). Proximity switch shall be set at 49 degrees +/- 1-degree dump angle to alert the operator and prevent the hoist cylinder from going full stroke. Proximity switch shall be mounted in an accessible area at the hoist cradle, located away from road splash. Ref: Automation direct inductive proximity sensor PN# PMW-OP-2H wired normally open with harness PN# EVT221 (**No substitute, standardization**). System shall be labeled "Body Limit".

Body-up Alarm System: Switch shall inform the operator by an illuminated console mounted light. An audible alarm (Chime) (Ref: Floyd Bell part # TCH-V86-530-QM shall be installed (**No substitute, standardization**) system shall alert the operator of the body being in the raised position. Alarm and light shall function as soon as the body is raised from the rested position. Proximity switch shall be mounted in an accessible area at the hoist cradle, located away from road splash. Ref. Automation direct inductive proximity sensor PN# PMW-OP-2H wired normally closed with harness PN# EVT221 (**No substitute, standardization**). System shall be labeled "Body-up".

All wiring for both switches shall be routed to prevent damage from heat, sharp edges and moving parts. Wiring harness connections shall be soldered and covered with heat shrink, dielectric grease shall be applied to sensor plug connections.

-30-
SPECIFICATIONS

AA1

I. GENERAL TRUCK SPECIFICATIONS: (Continued)

E. DUMP BODY AND EQUIPMENT MANDATORY MINIMUM SPECIFICATIONS: (Continued)

2. CENTRAL HYDRAULIC SYSTEM / HYDRAULICS:

Hydraulic Pump: Rexroth Part Number R910979162, Model A10V0100 LH rotation: KEYED Crankshaft Driven, **(No substitute, standardization)**. Pump shall include low oil shut down with console-mounted override switch. Shutdown shall be direct mounted to the pump. Remote mounted valve will be unacceptable. Valve shall be a normally closed, energize to open cartridge valve. Valve shall be controlled by the hydraulic control system. The pump shall match system flow and pressure (horsepower) requirements to provide maximum fuel economy. Ref: EQN-90. An unloader or by-pass system is not an acceptable means of regulating excess oil flow. To ensure responsive controls pilot pressure shall be set to 500 psi +- 5 psi.

Pump Mounting Bracket: Regardless of design the bracket shall be a minimum of 5/8 inch formed steel channel. The pump bracket shall be sloped to match the engine crankshaft. Width dimensions shall be full frame rail width. Bracketry to attach pump-mounting bracket to the truck frame rails shall be a minimum of 5/8 inch thickness. Brackets shall either be fully welded or use 3/4 inch grade 8 (eight) bolts of sufficient length and grade 8 (eight) locknuts, minimum of four (4) bolts per mounting side. Ref: EQN-90.

Hydraulic Pump Driveline: Hydraulic pump SHALL BE DRIVEN by a Spicer 1310 series or NEAPCO factory balanced drive shaft. Driveline shall be capable of 130-foot pounds of torque and have a tubular shaft of 1141 steel. Tubular shaft shall have 16-spline heat treated to 40 Rockwell hardness. A groove shall be machined the length of the shaft to provide proper phasing of universal joints at time of shaft assembly. Driveline installation shall be in accordance to manufacturer's recommended procedures. Slip assembly shall provide a minimum of 2.25 inch of travel to allow ease of engine drive belt replacement. The truck engine radiator and frame construction shall readily accommodate the installation of a front mounted crankshaft driven hydraulic pump. The engine crankshaft pulley or vibration damper shall be drilled and tapped to accommodate a power take off drive shaft adapter plate required under hydraulic system section of these specifications. Loc-tite shall be used for the installation of all mounting bolts. Universal joints shall be of the non-greasable lube for life design. Ref: EQN-90.

Hydraulic Hose: All hoses and hose ends shall be matched and assembled on a hose machine to prevent hose failure. All hydraulic plumbing practices shall conform to JIC H11 standards. Pressure hose from hydraulic pump to valve body shall be 100R17, pressure hoses shall be 100R2, return lines shall be 100R1 and suction lines shall be 100R4. Velocity in pressure lines shall not exceed twenty (20) feet per second, return lines not to exceed ten (10) feet per second, and not to exceed four (4) feet per second in suction lines. All hoses shall include JIC female swivel ends with the exception of the suction line. All hydraulic components shall have SAE porting wherever possible. All hydraulic hoses shall be securely clamped at approximately 18-inch intervals, shielded from exhaust and include a protective sleeve where necessary to prevent damage and/or failure. All hoses shall have JIC swivel connections at each end and be located in such a manner to aid in easy component replacement. Ref: EQN-94.

Hydraulic Alarm and Shutdown System: There shall be a low hydraulic oil alarm system to alert the operator of a low hydraulic oil situation and allow ample time to take preventative action and avoid damage to the central hydraulic system pump. It shall be operated via a 12-volt system. All wiring shall be routed to prevent damage from heat, sharp edges and moving parts. An in-tank float switch shall be mounted to provide a signal to the control system. The on-screen message and audible alarm shall come on whenever the oil level drops below a safe reserve, and the pump mounted low oil shutdown manifold shall deactivate to prevent pump damage. A console mounted low-oil override switch shall be provided to allow momentary operation in an emergency.

All electronics associated with the hydraulic system shall be protected against and shall not cause interference to the operation of the vehicle or the land mobile radio communications system or AVL when properly installed in the vehicle.

-31-
SPECIFICATIONS
AA1

I. GENERAL TRUCK SPECIFICATIONS: (Continued)

E. DUMP BODY AND EQUIPMENT MANDATORY MINIMUM SPECIFICATIONS: (Continued)

3 TARPING SYSTEM

Tarp System: Aero (**No substitute, standardization**)

Tarp Spool: Shall have a one-piece aluminum wind deflector, mounted onto the upper front portion of the bed bulkhead. Wind deflector shall meet stationary cab protector without interference during dumping. Provisions shall be made to position the arms below the top line of the side boards to achieve unobstructed transition from the bed ladder to the inside of the bed. It shall include an extruded aluminum roll pipe. Extrusion shall have a corrosion resistant steel stub shaft to connect it to a greasable bearing on the idler end of the roll pipe, idler bearing shall be installed on the outside of the wind deflector side plate.

Gear Motor: Shall be a 12-volt Electric Gear Motor designed to operate at fewer than 35 amps and weather resistant. Gear motor shall have protective cover. Gear case output shaft shall be corrosion resistant. Gear motor to have a minimum of a 3-year non-prorated limited warranty against wear out and manufacturing defects.

Controls: System to be operated by a low voltage rocker switch and control relay assembly. Control switch shall be located **IN** the hydraulic controller dash console, an externally mounted switch will not be accepted. For safety there is to be a weather resistant automatic reset circuit breaker mounted at the power supply to protect the complete tarp system from overload and short circuit. Location to be determined at pre-build meeting.

Power supply from chassis to bed shall be made through a spring-loaded contact plate mounted between the bed rail and chassis frame rail, mounting of contact shall be made with OEM's guidance and mounted parallel to the frame to help minimize flexing and losing contact. All wiring shall be protected from corrosion with wire terminal ends soldered and heat shrink connections. Ref. EQN-550.

Pivots & Arms: Pivots shall be mounted above the liquid tanks and below the top side rails with a maximum of 1 1/2 inch clearance from the sides of the body. The spring must have the ability to be preloaded with tension.

The arm offset angle shall follow the front top body line and not protrude into the side board area. Provisions shall be made to position the arms ahead of the side boards pockets to achieve unobstructed transition from the bed ladder to the inside of the bed. Ref. EQN-79AF

Tarp: The tarp material shall be fabric and suitable for covering asphalt and winter material/salt. Material shall be able to withstand temperatures associated with hauling hot asphalt for extended periods of time. Tarp to have 18 inch Rear Corner reinforcements.

Shall be equipped with the following: Full Flap Length Shock Cords (for tie down purposes)

- 12 inch Side Flaps
- 12 inch Tail Flap

I. GENERAL TRUCK SPECIFICATIONS: (Continued)

F. GENERAL PLOW MOUNTING / ACCESSORIES:

Front Plow Hitch: Side-mounting plates shall be constructed using 3/4 inch Steel. Lower plow mount bracket center shall be 16 inch to 17 inch from ground (both sides). Trucks that do not have a wing, "X" braces shall be installed using .31 inch wall 2 inch x 2 inch steel tubing. There shall be a minimum of five (5) 7/8 inch grade eight (8) bolts per side with washers and lock nuts to mount the plow frame to the truck frame. Lift height shall be sufficient to afford unrestricted lift for PennDOT plows, (16 inch minimum lift). Side strengthening bars (two per side) shall be fabricated using 3/4 inch steel, 16 inch long by 2 inch wide and mounted to the external side of the plow hitch. All grease zerks shall be surrounded by a short length of pipe (welded in place) or be in a recessed hole. The zerks for the plow arm bushings shall be mounted on the underside of the bracket.

Plow hitch pins shall be 1 1/4 inch diameter, length shall be sufficient to allow 3/4 inch between bottom of plow frame and "R" pin drilled hole. Pins shall be tapered, from 1 inch to half the diameter of the pin. **(No substitute, standardization)** Ref: EQN-50.

The hydraulic connections on the plow hoist cylinder and for the two way plow connections shall be the 5100 series winged typed couplers positioned as to keep them from being stuck and damaged, while connecting or disconnecting the front plow. **All other hydraulic connections mounted to the plow frame shall also be positioned to keep them from damage.** Ref: EQN-94 **(No substitute, standardization)**

Plow hoist cylinder shall be a welded barrel type, 4 inch X 10 inch stroke, 20 inch retracted 30 inch extended. Rod shall be full size diameter. Both barrel and rod pins shall be 1 inch diameter. Pins shall be tapered, from 1 inch to half the diameter of the pin. **(No substitute, standardization)**. Ref. EQN-24

Plow Balance: There shall be a Wojanis part number WSC-072-4-00 plow balance device installed. **(No substitute, standardization)**. Plow balance shall have the following specifications:

Valve to be designed to offset a specific (adjustable) plow weight when activated. Valve to be of cartridge and manifold design, and electrically activated. The valve shall be activated by a single solenoid.

The plow balance system shall not alter the operation of any other hydraulic function on the vehicle or have an adverse effect on the performance of other hydraulically operated equipment including wing plow, body hoist, plow hoist or angle, or spreader functions. All normal operations of the plow lift/lower function must be maintained without additional tasks. Operation of any electrical switches beyond the normal up/down command to raise or lower the plow shall not be acceptable. The use of a relay circuit to allow the plow to remain in the up position shall not be acceptable.

To guarantee safe operation of the vehicle, the plow balance system must operate with the following parameters: The system will remain electrically activated when lifting the plow from the road surface. Plow lift must be immediate. It is not necessary to turn off the system for plow lift. Plow lowering and return to balance mode must be done by activating the plow lever or switch to the lower mode.

The plow balance system must be able to hold the plow in the up position indefinitely.

The plow balance manifold shall be of cartridge style valving utilizing "floating" style cartridge valves. The valve body must be constructed of aluminum and have minimum construction hole plugs. All solenoid valve coils shall have manual override capabilities. Manifold must include a pressure test point for use when checking balance pressures. The pressure test point must be capable of tapping into the system at pressures of up to 5000 PSI.

I. GENERAL TRUCK SPECIFICATIONS: (Continued)

G. Optional Temperature Sensor:

There shall be pricing included on the bid sheet for:

- RoadWatch road/air temperature system
- Vaisala Surface Patrol DSP100 road/air temperature system

Either system shall be installed with hydraulic control system as an integrated temperature display.

H. Optional AVL Hardware Installed:

AVL Hardware option: Unit shall be equipped with a complete AVL hardware system installed and completely functional to work in conjunction with the Departments current AVL solution. Shall include but not limited to; GPS Transponder / Advanced Tele metrics System box, modem, GPS antenna, all wiring and connectors. All hardware shall be mounted within the truck cab and location shall be determined at pre-build meeting.

I. OPTIONAL WING PLOW SPECIFICATIONS:

1. INTENT STATEMENT:

Reference Gledhill Road Machinery Co. Patrol Wing(s) (**No substitute, standardization**).

Right Hand Patrol Wing 11FRPW-PENNDOT

Left Hand Patrol Wing 11FLPW- PENNDOT

Dual Wing Patrol Wings 11FDUAL-PENNDOT

The purpose of these specifications is to describe a full floating patrol wing plow with tripping action and telescoping action mechanism and a capability to lower the assembly into the travel position for improved visibility and to allow emergency egress.

It shall be the responsibility of the vendor to certify through proper chassis stress analysis the adequacy of the existing truck frames to accommodate the patrol wing plow in addition to a front mounted plow weighing approximately 3500 LB.

The aforementioned plow will be used for "severe duty" high-speed plowing by the Pennsylvania Department of Transportation. The attached drawings and written text are to be considered minimum and the manufacturer shall reinforce the plow, framing and hydraulic cylinders by means of gussets, or increased material strength or thickness to present a plow designed to meet the severe duty operational setting.

The Patrol Wing shall be designed to quick attach or detach independently utilizing the rear slide bracket from the A frame assembly. The front shall quick attach or detach between the front lift frame assembly and the trip mechanism utilizing a minimum 1 inch diameter pin. No part of the chassis or dump body assembly shall have to be moved or removed when attaching or detaching the wing.

When wing assembly is disconnected from the truck, no parts may extend past the bodyline of the truck. The Patrol Wing shall be installed in such a manner to ensure quick access to the engine and all accessories. Hood on dump truck shall tilt without obstruction.

All parts not specifically mentioned, which are necessary in order to provide a complete snowplow shall be furnished by the successful bidder. The plow fabrication and assembly shall be to the latest engineering techniques.

All steel unless otherwise specified, shall be hot-rolled steel (HRS) as per ASTM A-36 and all mounting hardware shall be Grade 8.

Areas of the wing plow tubes and cylinders that are likely to be stepped on when in the down position shall be coated with anti-skid paint, tape is unacceptable.

All cylinder rods shall be Chrome or Nitride plated

The front and rear wing plow braces shall be attached in such a way that will properly distribute the load to both chassis frame rails using a cross tube design and be approximately 154 inch +/- 2 inch (No Substitute, standardization) from the center of the rear cross tube to the center of the front cross tube. Ref. EQN-1097

SPECIFICATIONS

AA1

I. GENERAL TRUCK SPECIFICATIONS: (Continued)

I. OPTIONAL WING PLOW SPECIFICATIONS: (Continued)

2. SPECIFICATIONS:

Rear Wing Brace: The rear wing brace shall be (A)Frame style that will properly distribute the load to both chassis frame rails using a minimum 3 inch square cross tube and be approximately 154 inch from the center of the rear cross tube to the center of the front cross tube. Ref: EQN-1097 The (A) Frame shall incorporate 7inch x 15.3 LB/feet I Beam that will accept the rear wing post slide bracket for easy removal of the wing plow for non-winter or summer modes

Rear Wing Post Slide Bracket: shall incorporate a manual stop so contact between wing plow and truck cannot happen when the rear of the wing plow is raised to its highest position.

The top portion of the bracket shall incorporate a minimum 4inch x 15inch double acting lift cylinder with a chrome/nitride plated piston rod. This cylinder will raise and lower the rear wing plow for transport and plowing operations This cylinder shall have a 500-PSI relief valve when in float on the down side Ref: EQN-1099 Sheet 5

Rear Wing Post Slide Bracket: The bottom portion of the bracket shall incorporate a minimum 3inch X 27 inch double acting cylinder with a chrome/nitride plated piston. This cylinder shall extend and retract a telescoping strut that is constructed of 4inch O.D square tubing with 3inch O.D square tubing installed inside it. There shall be wear guides welded to the outside of the 3inch square tubing to prevent binding when retracting and extended the strut. There shall be a knuckle link at the end of the strut for connection to the horizontal bracing bracket on plow mold board. Ref: EQN:60A This Knuckle shall be of a one-piece cast design. (Use of welding components is unacceptable).The telescoping strut cylinder shall have an adjustable pressure relief valve installed in the hydraulic system for safety when contacting heaving objects in plowing operations. Ref:EQN-1099 Sheet 4

Front Wing Mast Bracing and support shall be attached in such a way that the load is properly distributed to both chassis frame rails using a cross tube and be approximately 154 inch from the center of the front cross tube to the center of the rear cross tube. Ref: EQN-1097 The front horizontal cross tube shall be minimum 7 inch X 4 inch X.3750.The formed wing mast mount shall be bolted to the horizontal cross tube with minimum grade 8, 0625 (5/8) bolts.

Front Wing Mast shall not block or interfere with O.E.M or aftermarket plow lights or mirrors. The front wing mast shall be minimum 7 inch x 15.3 LB/feet I Beam and shall incorporate a minimum 5/8 inch thick steel plate for the wing post slide. Minimum lift shall be 10 inch to allow sufficient clearance from bottom of plow to ground surface for transport. Front wing double acting lift cylinder shall be minimum of 3 inch X 18 inch with a chrome/nitride plated piston rod with the most weather resistant neoprene wiper seal. Ref: EQN-1099 Sheet 7

Tripping: The patrol wing shall be capable of a full trip moldboard design. The trip mechanism and linkage shall be heavy duty and be of adequate strength to handle the forces encountered when the wing moldboard is tripped. The trip mechanism shall be located at the front (nose end) of the wing moldboard. The trip mechanism shall utilize a rubber compression system that is adjustable by means of a 3/4 inch x 25 inch long threaded rod. The rubber compression spring shall be constructed from aeon A760-75 rubber. The tripping mechanism shall allow the wing moldboard to return to normal plowing position after it has encountered an obstacle. There shall be provisions to lock the plow from tripping when operations deem it necessary to have a rigid moldboard. Ref: EQN-1099 Sheet 3

Wing Plow Hydraulics All 3 cylinders will be double acting with a chrome/nitride plated piston rod with the most weather resistant neoprene wiper seals. All the cylinders shall be connected to the truck chassis hydraulics using 5100 series winged hydraulic couplers Ref: EQN-94. All hydraulic cylinders shall be controlled by a single joystick located conveniently in the cab with the hydraulic control system. In addition, there shall be 3 spool valves added to hydraulics. One to lift and lower the front of the wing, one to extend and retract the wing and one to fold up and lower the rear of the wing.

-35-
SPECIFICATIONS

AA1

I. GENERAL TRUCK SPECIFICATIONS: (Continued)

I. OPTIONAL WING PLOW SPECIFICATIONS: (Continued)

2. SPECIFICATIONS: (Continued)

Wing Plow Assembly: The wing assembly shall in no way interfere while turning either right or left with the steering tire. The wing shall not be less than 11 feet long overall, 27 inch (minimum) high at the front and 37 inch (minimum) high at the discharge end. The moldboard shall be fabricated from 0.1719-inch-thick (eight USS gauge) minimum steel and weigh a minimum of 755 LBS. It shall be drilled to accept standard AASHTO spacing as shown on attached drawing EQN-16A

Suspension Load booster: There shall be a Timbren load booster added to both the driver and passenger side steering axle to help support the leaf spring suspension with the load of the wing plow(s).

Plow Markers/Guides: Wing plow shall have a (visual) mechanical alarm system to help alert the operator of the position of the front of the wing plow. It must be visible from the driver's seat. There shall be two vertical highly visible coated cable plow guides on the front wing post. One shall be mounted to the stationary plow frame and one shall be mounted on the lift frame. Guides shall be mounted near of one another and the tops of the guides shall align when the wing plow is in the down position. There shall also be a vertical highly visible coated cable plow guide mounted on the top rear corner of the wing plow to help determine the location of the wing when in the down position. Ref: EQN-60A

Steel Blade: The cutting edge shall be of 1/2 inch x 6 inch C1090 steel, at least 10 feet long. Per attached plow blade drawing, EQN-16A. The wing plow shall have two cast wing shoes.

Swivel Knuckle: Swivel shall be of bolt on design to extension tube. The wing knuckle link at the rear of plow mold board connection shall be of a cast design. The use of welded together components will not be accepted.

3. MINIMUM ALTERATIONS:

The following minimum alterations shall be the responsibility of the successful vendor:

- a. Suspension Load booster: There shall be a Timbren load booster added to both the driver and passenger side steering axle to help support the leaf spring suspension with the load of the wing plow(s).
- b. Brace right hand side plate to truck frame.
- c. Add additional steel to side plates to provide increased strength and more substantial mounting for the 7-inch cross channel.

4. PLOW IDENTIFICATION:

Each unit shall bear the manufacturer's model number, serial number and weight affixed to the plow, by means of a permanently affixed (riveted) non-rusting metallic tag located on the right-hand backside of the moldboard as viewed from truck operator's seat. Sticker decals **will not** be accepted

-36-
SPECIFICATIONS

AA1

I. GENERAL TRUCK SPECIFICATIONS: (Continued)

I. OPTIONAL WING PLOW SPECIFICATIONS: (Continued)

5. PAINT:

Entire wing moldboard shall be painted with 2 coats of Flat PENNDOT yellow paint Ref: DuPont F9885, PPG 85246, Sherwin Williams 73266, Sikkens 4017 and NAPA 73266 for shade only. Frame and all underside and attached components shall be ground to eliminate weld splatter, scale, sharp edges, rust and oils prior to a rust preventive primer and top coats of yellow paint.

Body up fitter prior to painting **all** frame/body and upfit wing attachments shall be ground to eliminate splatter, scale and sharp edges. All metal surfaces shall be cleaned to eliminate rust and oils prior to primer and final painting. All surfaces to be painted, except for glass, rubber and those metallic accessories or fixtures constructed of rust-resistant (Aluminum and Stainless Steel) or plated material not normally painted shall be coated with one (1) coat rust preventive etching primer (1) coat of epoxy primer and two (2) coats of the body up fitters lead free Acrylic urethane black paint to match frame. Wing plow moldboards shall be prepared to eliminate weld splatter, scale, sharp edges, rust and oils before a rust preventive etching primer (1) coat of epoxy primer and two (2) coats of the body up fitters lead free Acrylic urethane paint and painted front and back with non-gloss PENNDOT Yellow paint, shade Ref. DuPont F9885, PPG 85246, Sherwin Williams 73266, Sikkens 4017 and NAPA 73266

6. CONSPICUITY TAPE:

The rear of the wing plow shall have a strip of retro-reflective sheeting across the top and down the outside in order to outline the plow when viewed from the rear in the lowered position. Shheeting shall also be placed on the length of the extension/retraction hydraulic cylinder and vertically on the rear most frame support of the moldboard plow as to make plow more visible in the raised/stowed position. Material shall be: 2 in/5.08 cm wide Reflexite Conspicuity II System of 3M Scotchlite Conspicuity Series 980, red/silver continuous backing. Ref: EQN-60A.

7. WING PLOW LIGHT:

The rear of the wing plow shall have a Whelen part # 01-066E765-500 light permanently mounted facing rearward and set to be a red steady burn. Light shall be controlled by a COMUS part # CB08-90 mercury switch. Light shall be wired to be on only when the plow is in the down position. There shall be a Deutsch connector installed at the front wing hinge point to allow for easy removal. All wiring connections shall be sealed and water tight. The wing plow manufacturer shall weld a 1/2 inch ID steel pipe on the rearward face of the plow, prior to painting. Pipe shall serve as a conduit to run the wiring for the light. Pipe shall be mounted toward the top and run across the entire length of plow webbing. Ref: EQN-60A

There shall be a Whelen part # 01-0418169-01F light to illuminate the wing plow. There shall be 1 light for each wing plow mounted on the same side as the wing (Dual wing will get 2 lights 1 on each side). Location will be determined at prebuild meeting. There shall be a dedicated OEM dash mounted switch that is properly labeled and illuminates.

-37-
SPECIFICATIONS
AA1

I. GENERAL TRUCK SPECIFICATIONS: (Continued)

J. OPTIONAL TOW PLOW:

1. TOW PLOW, ANTI ICE HITCH UPGRADE OPTION: (ECN's as applicable)

Truck shall be a complete turn key unit to operate a Viking Cives TP26 anti-ice tow plow.

The following shall be supplied in lieu of base hitch assembly.

Intent: Vehicle shall be capable of towing / operating a Viking Cives TP26 anti-ice tow plow. It is understood that the components specified are minimum and if the vendor's Engineering Department recommends or deems necessary, additional components, it shall be the successful vendor's responsibility to ensure complete 100% compatibility and successful integration / operation. The burden of responsibility is hereby placed upon the vendor's Engineering Department to supply a unit that is totally engineered.

Hitch: Shall install a heavy-duty 1 inch hitch plate attached and be reinforced to chassis frame.

Incorporate ICC bumper.

Provide and install, at 26 inch from ground to center of hitch eye, a Holland PH400 with cushion cylinder pintle hitch.

Install (2) heavy-duty Ken Forge PN# 800 1.00 inch diameter D-style rings rated at 85,000 lbs.

All other features for specifications must be met as in Section I.E.1 for hitch assembly.

Hydraulics: Shall supply and install any additional circuits to operate tow plow (with anti-icing package), including all hydraulic components, valves, hoses, fittings and electrical components to control plow lift, steering and anti-icing system on tow plow. All functions shall be operated through the central hydraulic controller. Control system shall control and capture all the data from the tow plow.

Hydraulic couplers shall be 5600 series stainless steel male (3) #8 and (2) #12 installed/mounted to the rear outside of the frame rails Ref. EQN-1081B. Coupler placement shall maintain a 1 inch clearance from end of installed coupler (facing rearward) to rear of pintle plate. Male couplers shall be mounted with adequate clearance for the female coupler to be attached, male couplers may be mounted/installed angled away from frame at 45 degrees. Each coupler shall have a permanently attached stamped metal tag identifying function. Couplers and plumbing shall be sized for required flow from OEM tow plow manufacturer (below). Dust boots shall be attached for each coupler.

- Moldboard 1 #8 1/2 inch hose
- Steering 2 #8 1/2 inch hoses
- Liquid pump 2 #12 3/4 inch hoses

All electrical connections, mounting and functionality shall be installed as per the current systems installation standards. All newly installed modules and valving shall be mounted in a vendor supplied weather tight enclosure on the tow vehicle. This enclosure shall not interfere with the operation of any other components and shall be securely mounted in an easily accessible location. Additional trailer plug shall be a 7-round pin. Tow plow shall have separate switches to control beacons, left side rear amber warning and flood/plow light. Ref. EQN-1081B

-38-
SPECIFICATIONS
AA1

I. GENERAL TRUCK SPECIFICATIONS: (Continued)

J. OPTIONAL TOW PLOW: (Continued)

2. TOW PLOW, GRANULAR UPGRADE OPTION: (ECN's as applicable) (Continued)

Truck shall be a complete turn key unit to operate a Viking Cives TP26 granular tow plow.

The following shall be supplied in lieu of base hitch assembly.

Intent: Vehicle shall be capable of towing / operating a Viking Cives TP26 tow plow that is equipped with an 8-cu yd granular hopper and a 225-gallon pre-wet system. It is understood that the components specified are minimum and if the vendor's Engineering Department recommends or deems necessary, additional components, it shall be the successful vendor's responsibility to ensure complete 100% compatibility and successful integration / operation. The burden of responsibility is hereby placed upon the vendor's Engineering Department to supply a unit that is totally engineered.

Hitch: Shall install a heavy-duty 1 inch hitch plate attached and be reinforced to chassis frame. Incorporate ICC bumper.

Provide and install, at 26 inch from ground to center of hitch eye, a Holland PH400 with cushion cylinder pintle hitch.

Install (2) heavy-duty Ken Forge PN# 800 1.00 inch diameter D-style rings rated at 85,000 lbs.

All other features for specifications must be met as in Section I.E.1 for hitch assembly.

Hydraulics: Shall supply and install any additional circuits to operate tow plow with an **8-cu yd granular hopper and a 225-gallon pre-wet system**, including all hydraulic components, valves, hoses, fittings and electrical components to control plow lift, steering, spreader and anti-icing system on tow plow. All functions shall be operated through one (1) Central hydraulic controller. Control system shall control and capture all the data from the tow plow.

Hydraulic couplers shall be 5600 series stainless steel male (7) #8 and (2) #12 installed/mounted to the rear outside of the frame rails Ref. EQN-1102. Coupler placement shall maintain a 1 inch clearance from end of installed coupler (facing rearward) to rear of pintle plate. Male couplers shall be mounted with adequate clearance for the female coupler to be attached, male couplers may be mounted/installed angled away from frame at 45 degrees. Each coupler shall have a permanently attached stamped metal tag identifying function. Couplers shall be sized for required flow from OEM tow plow manufacturer (below). Dust boots shall be attached for each coupler.

- Moldboard 1 #8 1/2 inch hose
- Steering 2 #8 1/2 inch hoses
- Liquid pump 2 #8 1/2 inch hoses
- Spinner 2 #8 1/2 inch hoses
- Spreader conveyor 2 #12 3/4 inch hoses

All electrical connections, mounting and functionality shall be installed as per the current systems installation standards. All newly installed modules and valving shall be mounted in a vendor supplied weather tight enclosure on the tow vehicle. This enclosure shall not interfere with the operation of any other components and shall be securely mounted in an easily accessible location. Additional trailer plug shall be a 7-round pin. Tow plow shall have separate switches to control beacons, left side rear amber warning and flood/plow light. Ref. EQN-1102

-39-
SPECIFICATIONS
AA1

I. GENERAL TRUCK SPECIFICATIONS: (Continued)

K. INSTALLATION PRACTICES:

Any place steel and aluminum contact each other Mylar (**No Substitute, standardization**) shall be used as a buffer. Laminate rubber is unacceptable.

All welding shall be in accordance with standard welding practices as set forth by the American Welding Society.

All vertical and horizontal seams of the body sides shall be continuous welds with full penetration.

All corners shall be angled or rounded for safety.

All mounting procedures shall be in accordance with NTEA standards.

All hoses shall be routed as to not interfere with any components, shall be protected from rubbing / chaffing other hoses or components.

All hydraulic circuits shall be tested for proper operation and flow. Control systems shall be tested/calibrated and programmed for Department material spread rates prior to delivery. Material spread rates will be disclosed at the pre-build meeting.

All electrical connections shall be treated with di-electric grease.

All electrical wiring and harnesses shall have an engineered strain relief system designed to eliminate stress on electrical connections, harnesses, control modules and any other associated electrical system components.

Each electrical circuit shall be supplied individually and properly sized, protected from weather and sealed to be watertight

All OEM connections within the battery box shall have attached non-metallic embossed labels/tags. Labels/tags applied with self-adhesives or stickers will not be accepted.

Any circuit deemed necessary for connection in the battery box by the body up-fitter or component manufacturer shall have attached non-metallic embossed labels/tags. Labels/tags applied with self-adhesives or stickers will not be accepted.

All open terminal connection shall be coated with 3M brand Scotchkote Electrical Coating FD.

The use of any of the following items or practices WILL NOT BE ACCEPTED.

The use of accumulators or auxiliary pumps

Non-steel fittings on hydraulic pressure lines

Excessive use of elbows on hydraulic lines

Use of thread tape on hydraulic fittings

Use of galvanized fittings or components on hydraulic system

Improper hydraulic line size

Use of high-pressure hose for hydraulic suction line

Scotchlok-type wire splices

Non-insulated wire splices

Improper hose or wire routing near exhaust, over-sharp edges or through holes without grommets, or sharp edges

Improperly prepared, primed and painted surfaces

Non-fused electric circuits

Hydraulic circuits without pressure relief protection

Laminated Rubber

All zerk fittings shall be threaded

-40-
SPECIFICATIONS

AA1

I. GENERAL TRUCK SPECIFICATIONS: (Continued)

L. SAFETY:

Anti-slip paint is required on all handholds and areas designed to be walked/stepped on, for the entire length, (tape is unacceptable).

All handrails, ladders, and step configurations shall be built for three points of contact.

There shall be two-wheel chocks per truck Ref: buyers WC1467 or equal with a rope. Mounting location will be determined at pre-build meeting. EQN-82B.

All corners shall be angled or rounded for safety.

Compliance shall be made per EQN-118.

Cab and body shall have reflective enhancement per EQN-122

Emergency triangle warning kit, with hold down. Warning Triangle Flare Kit, Ref: KD 610-4645, KD Lamp Co. (Tel: (513) 621-4211) or equal, stowed (fastened) in the cab. Ref: EQN-66A

Fire extinguisher: Rechargeable with vehicle mount, 3A: 40B: C minimum. Mounted in the cab for easy and quick access.

There shall be a permanent decal, 2-inch-high red letters on white background affixed by the driver side door handle stating the overall maximum height of the completed and unloaded unit. Example: HT-__' __" Ref: EQN-552

There shall be a permanent decal, "Three Point Contact" located at each entry point of the truck cab and at the bed ladder area per EQN-552-1. Exact location to be determined at pre build meeting.

II. DRAWINGS:

EQN-16A	dated	Rev.	08-09-18	2 sheets	STEEL CUTTING EDGES
EQN-24	dated	Rev.	12-11-06	2 sheets	PLOW RAM
EQN-32	dated	Rev.	07-24-18	1 sheet	DUMP TRUCK CHAIN BOXES
EQN-50	dated	Rev.	08-02-18	4 sheets	FRONT PLOW HITCH ASSEMBLY
EQN-60A	dated	Rev.	07-06-17	2 sheets	SNOWPLOW PATROL WING
EQN-62	dated	Rev.	06-05-14	2 sheets	BED PROP SYSTEM
EQN-66	dated	Rev.	07-20-09	2 sheets	SPLASH GUARDS-RUBBER TRAILER & TRUCK
EQN-66A	dated	Rev.	07-13-17	1 sheet	TRIANGLE STORAGE BOX
EQN-78	dated	Rev.	10-27-06	1 sheet	CB RADIO CONNECTIONS
EQN-78A	dated	Rev.	07-13-17	3 sheets	AIR TAILGATE, HARDWARE
EQN-79AF	dated	Rev.	08-06-19	7 sheets	AUGER FLOOR BODY
EQN-80A	dated	Rev.	08-02-18	1 sheet	WIRING DIAGRAM 7 WAY ROUND PIN FEMALE CONNECTOR
EQN-82B	dated	Rev.	07-17-17	1 sheet	CHOCK AND HOLDER
EQN-90	dated	Rev.	07-20-09	2 sheets	PUMP MOUNTING BRACKET & PTO ASSEMBLY
EQN-94	dated	Rev.	08-02-18	4 sheets	HYDRAULIC HOSE MOUNTING & REQUIREMENTS
EQN-118	dated	Rev.	06-26-09	1 sheet	UNDERRIDE PROTECTION
EQN-122	dated	Rev.	07-24-18	3 sheets	DUMP BODY REFLECTIVE SHEETING
EQN-180	dated	Rev.	07-26-18	2 sheets	HEADLIGHT ADJUSTMENT BRACKET
EQN-351A	dated	Rev.	06-19-13	2 sheets	FAST LUBE OIL CHANGE SYSTEM

-41-
SPECIFICATIONS
AA1

II. DRAWINGS: (Continued)

EQN-501	dated	Rev.	06-08-09	2 sheets	CENTRALIZED LUBE SYSTEM
EQN-507B	dated	Rev.	07-24-18	1 sheet	DUMP TRUCK WEIGHT DISTRIBUTION MINIMUM DATA REQUIRED
EQN-508	dated	Rev.	11-03-09	1 sheet	VALVE ENCLOSURE TANK COMBO
EQN-509	dated	Rev.	08-01-18	1 sheet	DUMP TRUCK SPREADER CONTROL BASE WITH RADIO BRACKET
EQN-550	dated	Rev.	05-28-13	1 sheet	WIRELESS CONNECT AND TARP
EQN-552	dated	Rev.	07-25-18	1 sheet	MAX TRAVEL HEIGHT STICKER
EQN-552-1	dated	Rev.	07-06-17	1 sheet	THREE POINT OF CONTACT STICKER
EQN-557	dated	Rev.	05-20-13	1 sheet	SHOVEL HOLDER
EQN-561	dated	Rev.	01-06-14	1 sheet	TAILGATE
EQN-562	dated	Rev.	01-08-14	1 sheet	POWER DISTRIBUTION BOX
EQN-1081B	dated	Rev.	05-23-19	2 sheets	ANTI-ICE TOW PLOW TRUCK
EQN-1090	dated	Rev.	07-26-19	3 sheets	FLIP STEP
EQN-1097	dated	Rev.	07-12-19	1 sheet	WING PLOW TOLERANCE
EQN-1099	dated	Rev.	07-18-19	4 sheets	WING PLOW MOUNTS
EQN-1102	dated	Rev.	07-15-19	2 sheets	GRANULAR TOW PLOW TRUCK
EQN-1105	dated	Rev.	07-29-19	1 sheet	TAILGATE LATCH

NOTE: Drawings appear in SAE.

The above referenced drawings shall become part of these specifications.

These drawings reflect the intent of the Department and any discrepancies shall be resolved at the pre-build meeting between the vendor and the Chief of the Fleet Management Division.

DRAWINGS APPEAR AT THE END OF THE SPECIFICATIONS.

-42-
SPECIFICATIONS
AA1

III. MANUALS:

The successful vendor shall furnish all applicable manuals per unit:

- 1 Operator's
- 1 Parts
- 1 Service complete engine and chassis
- 1 Engine
- 1 Transmission (Automatic)
- 1 Body and Sub-frame (Parts and Service)
- 1 Complete set of manuals for any additional items/equipment added to a piece of equipment.
- 1 Electrical System Charts
- 1 Control System/Hydraulic and Electrical System Schematics
- 1 Lube System Grease/Electrical Schematics

The manuals listed above shall be official O.E.M. publications supplemented with technical manuals for all components as published by sub-vendors/manufacturers.

Parts Service Manual presented must be relative to "all" items utilized to build these units, with appropriate part numbers.

Delivery of these manuals, including manual revisions shall be completed with delivery of the first unit in a series and with the pilot of a new build, VIN and body serial specific.

Any changes requested by the Department or deviations granted by the department to the OEM chassis or body up fitter shall have updated manuals supplied with serial number specified.

Delivery of these manuals shall be completed with delivery of the first unit of each series.

Manuals shall be supplied on thumb drive in lieu of paper manuals for each new build or at any time a change is made to series.

Manuals may be supplied on a dedicated website (OEM chassis ONLY) in lieu of paper manuals.

It shall be the responsibility of the OEM chassis and or the sub vendors to provide revisions to corresponding / Subsequent specific manuals with any changes specific to chassis or body serial numbers.

IV. TRAINING:

See training information attachment in the bid package.

-43-
SPECIFICATIONS
AA1

V. WARRANTY:

Per PCID No. 1075, and the additional specific warranty items stated below.

1 year starting from the Department's in-service date.

The warranty start-up date shall be defined as the date of transfer from the PennDOT Fleet Management Division to the designated county location. This will be considered the date of delivery to the county and NOT the date of delivery by the successful bidder to the Department. The PennDOT Fleet Management will supply the actual start-up date, equipment number, and serial number of the machine, via email, to the successful bidder. It is the responsibility of the successful bidder to ensure that the equipment manufacturer recognizes and applies the Department's actual warranty start-up date in their database.

This warranty is in effect as follows, starting from date of acceptance by the Department. Warranty shall not be voided due to Department operation as explained in the Intent Statement. It is understood that the components specified are minimum and if the manufacturer's Engineering Department recommends or deems necessary a more robust component, other than specified, be installed to meet the vehicles intent statement and to not void the warranty, it shall be the bidders/vendors responsibility.

MANUFACTURE IN-HOUSE WARRANTY PROGRAM:

The Manufacture and the dealer must agree and comply to the Manufacture In-House Warranty Program. A signed letter from the manufacture on the manufacturer's letterhead must be included with the bid. The signed letter must agree to the Commonwealth's Manufacture In-House terms as set out in this IFB.

PRIOR TO BID ALL OEM CHASSIS MANUFACTURES MUST ESTABLISH AN IN-HOUSE WARRANTY PROGRAM AND SERVICE AGREEMENT DIRECTLY TO THE DEPARTMENT.

AFTER CONTRACT AWARD IF THE DEPARTMENT DESIRES TO PARTICIPATE, THE PROGRAM SHALL BE OPERATIONAL (user name/password(s) established, etc.) PRIOR TO DELIVERY OF THE FIRST UNIT. ESTABLISHED WARRANTY AND SERVICE AGREEMENT SHALL REMAIN INSERVICE FOR THE FULL TERM OF EACH UNIT REGARDLESS OF THE AMOUNT OF UNITS WITHIN THE FLEET.

Warranty repairs shall be completed at the manufacturer's location or in-house field repair completed by PENNDOT. It shall be the Departments discretion to repair internally or transport the unit to the dealership. The manufacturer shall reimburse the Department at the manufacturers standard published in-house labor rate. The labor rate shall be mutually agreed upon between the Department and the vendor/bidder.

Any and all training for in-house warranty work will be provided by the Manufacturer at no expense to the Commonwealth.

All in-house warranty documentation shall be delivered with the pilot model. All warranty documentation (extended warranty service contracts and coverage) shall be delivered with the pilot model.

Prior to bid, the In-house warranty program shall provide the department the availability to file warranty claims directly to the OEM manufacturers warranty website for repairs made in-house by department personnel during the equipment's specified warranty period. Supplying manufacture shall ensure that there are authorized OEM repair facilities within the commonwealth of PA. capable and in agreement to perform repairs after the warranty period ends and throughout the department owned equipment's life cycle.

V. WARRANTY: (Continued)

BUMPER-TO-BUMPER WARRANTY:

1 year starting from the Departments acceptance date.

RADIATOR WARRANTY:

Manufacturer's standard service and warranty policy for radiator minimum shall be for one (1) year, 100% parts and labor.

ENGINE WARRANTY:

The successful vendor and or supplying OEM shall provide the Department with a 100% parts and labor engine warranty, shall include all engine componets internal and external FOR 60 months / 150,000 miles minimum.

ENGINE OIL PAN:

The oil pan and all fastening hardware shall be warranted against corrosion, rust, rust thru etc. regardless of atmospheric conditions for 5 years, 100% parts and labor.

EMISSION WARRANTY:

The successful vendor and or supplying OEM shall provide the Department with a 100% parts and labor warranty for all emission related components to include the diesel particulate filter (DPF) FOR 60 months / 100,000 miles minimum, unlimited engine hours.

TRANSMISSION WARRANTY:

Manufacturer's service and warranty policy for automatic shall be three (3) years 100% parts and labor. This warranty shall include all internal and external components related to the automatic transmission.

DIFFERENTIAL/AXLE WARRANTY:

Manufacturer's service and warranty policy for differential and axles shall be for three (3) years 100% parts and labor.

DUMP BODY WARRANTY:

Structural Integrity and workmanship of body shall be guaranteed for five (5) years, parts and labor. A decal shall be affixed to the driver's door, on the inside, stating the company's name, model, serial number, address and phone number.

Body hoist assembly 3 years, 100% parts and labor.

Tailgate spring-over-air cylinder system, 3 years 100% parts and labor.

CENTRAL HYDRAULIC SYSTEM:

Complete Central Hydraulic system and components 1-year 100% parts and labor including but not limited to the following:

Saur Danfoss Valve

Controller

Electronic Joysticks

All wiring harnesses shall be warranted for 5 years 100% parts and labor.

VI. WARRANTY: (Continued)

HYDRAULIC PUMP

Manufacturer's service and warranty policy for hydraulic pump shall be three (3) year 100% parts and labor.

UNDER TAILGATE SPREADER if Equipped:

Warranty will be for a minimum of one (1) calendar year on the entire spreader, and two (2) calendar years for hydraulic motors (spinner & auger) and sensor or manufacturer's standard commercial term (whichever is greater), from date of departments acceptance. If the manufacturer neglects or fails to correct defect(s) during the warranty period, their responsibility shall continue until such time as it takes to correct the defect(s). The manufacturer is expected to respond to warranty problems and administer effective solutions in the best interest of the Commonwealth. The successful bidder shall be an authorized dealer for the proposed spreader/s and shall comply with the manufacturer's warranty or authorize a qualified dealer in the locality in which the unit is assigned, to do whatever is required to comply with the manufacturer's warranty without cost to the Commonwealth.

The vendor will replace, free of charge within two (2) years from date of county acceptance, any spinner, auger motors and sensors which in the judgment of the manufacturer has failed because of defective material or workmanship, provided it is shown to be properly mounted, and not subject to abuse in operation or assembly.

The successful bidder shall be an authorized dealer for the proposed spreader/s and shall comply with the manufacturer's warranty or authorize a qualified dealer in the locality in which the unit is assigned, to do whatever is required to comply with the manufacturer's warranty without cost to the Commonwealth.

BODY ELECTRICAL/LIGHTING:

Wiring harness shall be 5 years 100% parts. First year shall include 100% labor.

All LED lights and lighting system controller shall be 5 years 100% parts.

WING PLOW WARRANTY:

The manufacturer's standard service and warranty policy shall be for a minimum of two (2) years. This warranty shall start on the final date of acceptance of the entire order and continue for the two (2) years thereafter, (2) full winter plowing seasons.